

THE COTTAGE GROVE FAULT SYSTEM IN SOUTHERN ILLINOIS

W. John Nelson and H.-F. Krausse,
with contributions by Hubert M. Bristol

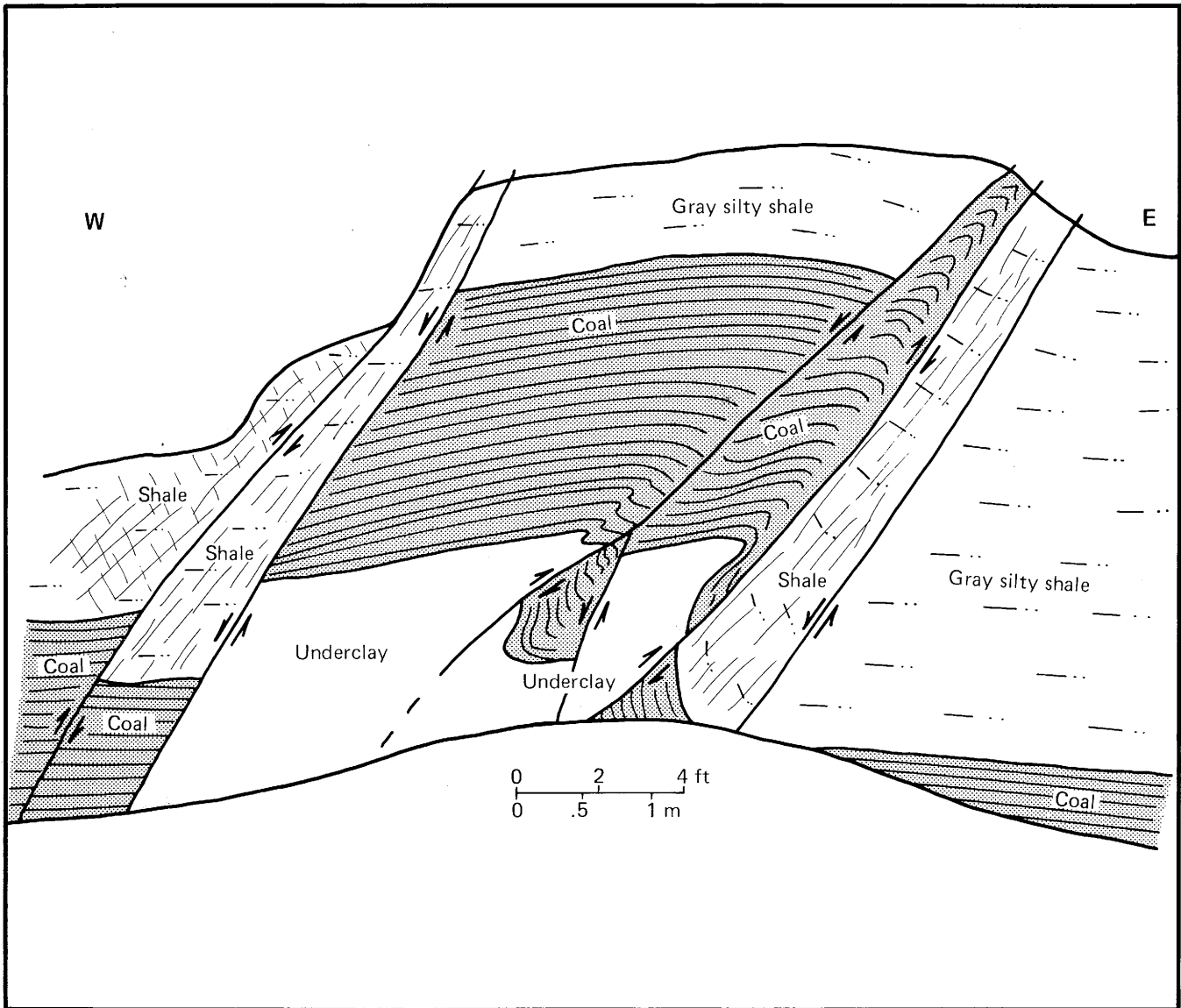

COVER: A fault found in the Springfield (No. 5) Coal in
Study Area 1. (See figure 26A.)

Nelson, John W.

The Cottage Grove Fault System in southern Illinois /
W. John Nelson and H.-F. Krausse with contributions by
Hubert M. Bristol. — Champaign, Ill. : Illinois State
Geological Survey, 1981.

65 p. : 1 plate ; 28 cm. — (Circular / Illinois State
Geological Survey ; 522)

1. Coal—Illinois. 2. Faults (Geology)—Illinois. I. Title.
II. Krausse, H.-F. (Hans-Friedrich). III. Bristol, Hubert M.
IV. Series.

Draftsman, Fred Graszer
Editor, Ione L. Nielsen Typesetter, Rebecca A. McFarland

Printed by authority of the State of Illinois/1981/3000

THE COTTAGE GROVE FAULT SYSTEM IN SOUTHERN ILLINOIS

W. John Nelson and H.-F. Krause,
with contributions by Hubert M. Bristol

CONTENTS

ABSTRACT	1		
INTRODUCTION	1		
Previous studies	2		
Method of study	2		
Regional structural setting	3		
Stratigraphic setting	5		
STRUCTURE OF COTTAGE GROVE FAULT SYSTEM	7		
Master fault zone	7		
Subsidiary faults and igneous dikes	15		
Subsidiary anticlines	18		
ORIGIN OF COTTAGE GROVE FAULT SYSTEM	24		
Amount of offset	28		
Age of faulting	29		
NORTH-SOUTH FAULTS NEAR COTTAGE GROVE FAULT SYSTEM	29		
Small thrust faults in Saline and Williamson Counties	29		
Rend Lake Fault System	30		
White Ash Fault Zone	31		
Dowell Fault Zone	32		
DETAILED STRUCTURE OF SELECTED AREAS IN UNDERGROUND MINES	33		
Study Area 1	33		
Study Area 2	34		
Study Area 3	35		
Study Area 4	41		
Study Area 5	45		
Study Area 6	50		
Study Area 7	56		
ECONOMIC EFFECTS OF FAULTING	59		
Oil and gas	59		
Coal mining	61		
REFERENCES	64		
PLATE			
1. The Cottage Grove Fault System and adjacent structures (approximate scale 1:99,400)			

Acknowledgments

We wish to express our appreciation to the coal mining industry of Illinois, without whose help and cooperation this study would not have been possible. We owe a special debt of gratitude to the companies for the wealth of data they provided and for their patient support of our detailed mapping in their mines. Individuals worthy of special mention include M. V. Harrell, Ben Kincer, Keno Koehl, Bill Mullins, and Roger Nance of Freeman-United Coal Mining Company; Erich Egli, Bob Gullic, and Walter Lucas of Sahara Coal Company; and Larry Lewis and Roger Snow of Zeigler Coal Company.

We also wish to thank Larry Bengal, Christopher Ledvina, Roger Nance, and John T. Popp for their assistance during the detailed mapping in underground mines.

THE COTTAGE GROVE FAULT SYSTEM IN SOUTHERN ILLINOIS

ABSTRACT

The Cottage Grove Fault System is one of the major tectonic fault systems in southern Illinois. It extends from the Saline-Gallatin County line westward at least as far as Campbell Hill in Jackson County, a distance of about 70 miles (113 km). The zone of faulting is as much as 10 miles (16 km) wide, and individual faults have as much as 200 feet (60 m) of vertical offset.

The system comprises three major elements: (1) a master fault zone, (2) subsidiary faults, and (3) subsidiary anticlines. The master fault is an east-west trending zone of faults that follows the central axis of the system. The master fault zone curves, branches, and is interrupted several times along its length. It has a complex structure of dominantly high-angle faults that show strong indications of strike-slip movement. Subsidiary faults strike mainly northwest-southeast and are mostly en echelon high-angle normal faults, although some faults show reverse or oblique-slip movements. Igneous dikes in Saline and eastern Williamson Counties were intruded contemporaneously with faulting. Subsidiary anticlines occur close to the master fault zone, and their axes strike parallel to the master fault zone or form right-handed en echelon sets. Dips on the anticlinal beds are gentle on the flank away from the master fault zone and relatively steep on the side facing the fault zone.

The combination of large- and small-scale structures of the Cottage Grove Fault System indicates that the system developed under a field of right-lateral wrenching stresses, probably induced by horizontal slippage along a zone of weakness in the basement. Horizontal offset across the system as a whole in Pennsylvanian rocks does not exceed one mile (1.6 km) and probably is on the order of several hundred to several thousand feet in most places.

No indications were found that the Cottage Grove Fault System links with either the Rough Creek-Shawneetown Fault System on the east or the Ste. Genevieve Fault Zone on the west. The age of faulting in the Cottage Grove system is certainly post-middle Pennsylvanian and pre-Pleistocene. The most probable time of faulting is early Permian, contemporaneous with the Appalachian and Ouachita disturbances.

Although several finds of oil and gas have been made in structural traps along the Cottage Grove Fault System, production from the area south of the system has been negligible. This is partly due to (1) the loss of effective porosity in Chesterian sandstones by mineralization and (2) relatively sparse exploration, especially in strata below the Ste. Genevieve Limestone.

The fault system transects a major coal mining region, and its effect on mining operations is serious and detrimental. Faults add to the costs of production, increase hazards in mines from roof failure, and may cause influx of water and gas. The structural complexity makes prediction of faults difficult without closely spaced and carefully logged exploratory drilling. A thorough understanding of the nature of faulting is needed to mine successfully in faulted areas.

INTRODUCTION

The Cottage Grove Fault System (CGFS) is one of the major structural features of southern Illinois. From a point near the sharp southward curve of the Shawneetown Fault in T. 9 S., R. 7 E., the system extends at least 70 miles (113 km) westward across southern Illinois. The fault zone is as much as 10 miles (16 km) wide, and individual faults have up to 200 feet (60 m) of vertical displacement. The system is complex, including major and minor faults that exhibit normal, reverse, strike-slip, and oblique-slip movement, as well as numerous subsidiary anticlines, synclines, and drag folds. The variety of structural features found in this fault system is probably greater than that of any other fault system in Illinois.

The Cottage Grove Fault System has considerable economic significance. Several discoveries of oil and gas have been made in structural traps along the system. The zone of faults generally marks the southern limit of petroleum production in Illinois. The fault system also crosses one of the main coal-producing areas of Illinois and adds considerably to the danger and expense of mining there. Faults interrupt the continuity of the coal seams, weaken the roof and ribs of mines, and provide pathways for water

and gas to enter workings. The complexity of the fault system has made projection of mine workings a difficult task.

This report has two goals: (1) To contribute to the understanding of the nature and origin of the Cottage Grove Fault System and its relationships to the tectonic framework of the midcontinent region. (2) To serve as a guide for locating and predicting faults that influence the minability of coal and the accumulation of petroleum.

Previous studies

The area of the Cottage Grove Fault System is mostly mantled by Pleistocene materials; very few exposures of bedrock are available at the surface. The faults were unknown until drilling and coal mining began to reveal the subsurface structure. The first published reference to possible existence of faults was made by DeWolf (1907), who reported that coal-test drilling in eastern Saline County indicated either an east-west trending anticline or a fault downthrown to the south. Soon afterward, underground coal mining began on a large scale near Harrisburg, and mines began to encounter faults. Cady (1925) presented a structure map showing quite accurately the position of the main fault in western Saline and in Williamson Counties. Butts (1925) named the fault system for Cottage Grove, a village about 7 miles (11 km) east of Harrisburg in Saline County. Fisher (1925) provided sketches and descriptions of faults in coal mines of eastern Jackson and western Williamson Counties, and he suggested a link of these faults with those of Saline County.

Continued mining and drilling expanded the knowledge of the structural pattern. Cady et al. (1938 and 1939) and Stonehouse and Wilson (1955) released successively improved maps showing details of the CGFS. Mining and drilling are still continuing, and maps of the fault system are continually being refined.

As the basic pattern of the Cottage Grove Fault System became known, geologists began to relate it to the regional tectonic setting and to speculate on the origin of the faulting. Clark and Royds (1948) considered it to be a westward extension of the Shawneetown-Rough Creek Fault System and suggested, on the basis of the observed near-vertical fractures, open fissures, apparent "scissoring," and other features, that strike-slip movement was involved. Heyl and Brock (1961) concurred on the matter of strike-slip movement but further specified that the displacement was right lateral. Heyl et al. (1965) extended the zone of right-lateral faulting into Missouri and proposed that the observed near-surface faults reflect movements along a major basement lineament that, according to them, has been active from Precambrian through Holocene times. Most geologists today concur that the CGFS shows right-lateral shear (Wilcox, Harding, and Seely, 1973).

Heyl (1972) proposed that the Cottage Grove Fault System is an element of the "38th Parallel Lineament." This proposed lineament is a zone of faults, igneous intru-

sions, and various other structural anomalies which extends from the valley of the Shenandoah River in Virginia to the foot of the Rocky Mountains in Colorado, a distance of nearly 2,000 miles (3,200 km). Heyl believes the lineament may be the result of movements along a major right-lateral shear in the basement. Many structural geologists do not accept Heyl's far-reaching interpretations. The CGFS may not even connect with the Shawneetown Fault immediately to the east. Other links in the 38th Parallel Lineament are far more tenuous, and many of its elements show no indications of right-lateral movements. Nonetheless, few geologists today would dispute the contention that the CGFS is a right-lateral shear zone.

Method of study

Nearly every fault of the Cottage Grove Fault System presently exposed in active underground coal mines was examined and mapped in detail during this study. Mapping was generally done at a scale of 1:1200 on base maps provided by the coal companies. All faults within the study areas were plotted with symbols to show types of faults and amount of displacement. Many other features were also mapped, including fractures, joints, roof lithologies, and locations of roof failures. In complex areas larger-scale maps were produced and supplemented by detailed notes, drawings, and photographs.

Maps of mines prepared by coal companies were the main source of data for the overall regional mapping (plate 1). The Illinois State Geological Survey has a large collection of these maps, which vary considerably in the precision with which faults are shown. Some maps show faults with as little as 1 foot (0.3 m) displacement, but others show only the major faults that severely hindered mining. Few maps indicate displacement on faults, and those that do are often inconsistent and inaccurate. None of the maps indicate the dip of the fault plane, nor are normal faults distinguished from reverse faults. Multiple faults and sets of faults commonly are shown by a single line on the maps.

In some cases more information on faults in abandoned mines could be gathered from the Survey's collection of mine notes. Geologists of the Illinois State Geological Survey, notably Gilbert H. Cady, K. D. White, and George Wilson, made abundant notes and sketches of faults and related features in now-abandoned workings.

Faults that are not plotted on mine maps sometimes can be inferred from disruptions to the normal pattern of mining. Faults often exist between boundaries of mines. A comparison of surveyed elevations of the coal in adjacent mines may allow estimates of displacement on such faults. Elevation sightings are plotted directly on some mine maps. These elevations were contoured to provide additional information on faults and related structures.

Data from drill holes were used to supplement information gathered from mine maps. A number of coal-test

drill holes and oil wells passed directly through faults, as was indicated by missing or repeated strata. In most cases, faults identified from drill holes can be correlated with faults known from coal mines. However, several major faults evidenced by data from drill holes in Mississippian strata are not reflected in the coal. This observation indicates that individual faults change vertically as well as laterally.

The Cottage Grove Fault System is characterized by rather sharp folds along the trend of the master fault. Locally coal beds and associated strata are inclined 15 degrees or more; therefore, major changes in elevation between adjacent drill holes do not necessarily indicate faults. Thus, drill holes must be closely spaced to allow accurate determinations of throw along the master fault. Coal companies sometimes have spaced holes as closely as 100 feet (30 m) to locate faults in advance of mining. Drilling is generally of little value in predicting even major faults if the spacing of holes is greater than about 1,000 feet (300 m).

The regional structure map included with this report (plate 1) was prepared using all available sources of data. The structures are plotted for the Springfield (No. 5) [also known as Harrisburg (No. 5)] Coal Member in Saline County and for the Herrin (No. 6) Coal Member in Williamson County and westward. These are the principal seams mined in the respective areas. Most of the data were obtained from mine maps. The interval between the two coals varies from about 30 to 100 feet (9 to 30 m) within the study area. The fault pattern should be only slightly affected by the change of datum plane. The boundaries of mined-out areas are shown on plate 1.

Regional structural setting

The Cottage Grove Fault System marks the southern margin of the Fairfield Basin, a deep portion of the Illinois Basin (fig. 1). In the vicinity of the fault system the sedimentary strata generally dip northward at 25 to 100 feet per mile (1:200 to 1:50). The western extent of the Cottage Grove Fault System crosses the southern edge of the Western Shelf. Dips on the Western Shelf are small, generally less than 25 feet per mile (1:200).

On the east the Cottage Grove Fault System approaches the Rough Creek-Shawneetown Fault System (figs. 1 and 2); there are no indications that the two systems join. The Rough Creek-Shawneetown Fault System is a continuous structure, consisting of the Rough Creek Fault System in Kentucky and the Shawneetown Fault Zone in Illinois. The Rough Creek Fault System is a zone of multiple high-angle faults forming a series of narrow horsts and grabens and trending roughly east-west. The maximum displacement on individual faults in Kentucky is roughly 600 feet (180 m), with the overall throw of the Pennsylvanian strata down to the north. On the Shawneetown Fault Zone, a high-angle reverse fault, the displacement reaches

a maximum of about 3,500 feet (1,070 m) (Cote, Reinertsen, and Killey, 1969) down to the north—the largest displacement of any fault known in Illinois. At its western end the Shawneetown Fault Zone turns abruptly southwestward trending parallel with the faults of the Fluorspar Area Fault Complex (fig. 2).

Opinions differ on the origin of the Rough Creek-Shawneetown Fault System. Heyl (1972) believes it to be the result of right-lateral strike-slip movement along the 38th Parallel Lineament. Smith and Palmer (1974) regard the system as a high-angle thrust fault caused by compression from the south. Schwalb (1979) contends that essentially vertical movements were involved; the south block moved downward in the early Paleozoic and upward during the later Paleozoic.

The Fluorspar Area Fault Complex (figs. 1 and 2) lies south of the Shawneetown Fault Zone and the Eagle Valley Syncline; it consists of closely spaced faults trending dominantly northeast-southeast. Most of the faults are high-angle normal faults, but high-angle reverse and strike-slip faults also have been recognized (Baxter, Desborough, and Shaw, 1967; and Trace, 1974). Individual faults have as much as 1,600 feet (490 m) of vertical displacement (Baxter, Potter, and Doyle, 1963). The major faults strike northeast-southwest and disappear beneath the sediments of the Mississippi Embayment to the south. Heyl et al. (1965) linked the Fluorspar Area faults with the New Madrid Fault Zone and hypothesized that both acted as shear-relief fractures for the right-lateral Shawneetown-Rough Creek Fault System.

North of the Shawneetown Fault is the north-northeast trending Wabash Valley Fault System (Bristol and Treworgy, 1979). This system is characterized by parallel and high-angle, normal faults having as much as 480 feet (150 m) of displacement. No indication of reverse or strike-slip faulting has been reported. The position and orientation of the Wabash Valley faults may suggest a link with faults of the Fluorspar Area Fault complex, but none of the Wabash Valley faults have been shown to intersect or cross the Shawneetown Fault Zone.

The Rend Lake Fault System (Krause and Keys, 1977; Keys and Nelson, 1980) extends northward from the Cottage Grove Fault System just northwest of Johnston City, Illinois, to the vicinity of Waltonville, over a distance of about 35 miles (56 km). It consists of a series of high-angle normal faults with a maximum observed displacement of 55 feet (17 m) at the level of the Herrin (No. 6) Coal. Most of the large faults are downthrown to the east, but some faults are downthrown to the west. Sets of individual faults commonly form an en echelon pattern. A few small accompanying subsidiary reverse faults have been recognized. The Rend Lake faulting has been interpreted as the result of east-west extension that is due to differential uplift and subsidence (Keys and Nelson, 1980).

The Du Quoin Monocline (figs. 1 and 2) extends northward from the Cottage Grove Fault System just south of

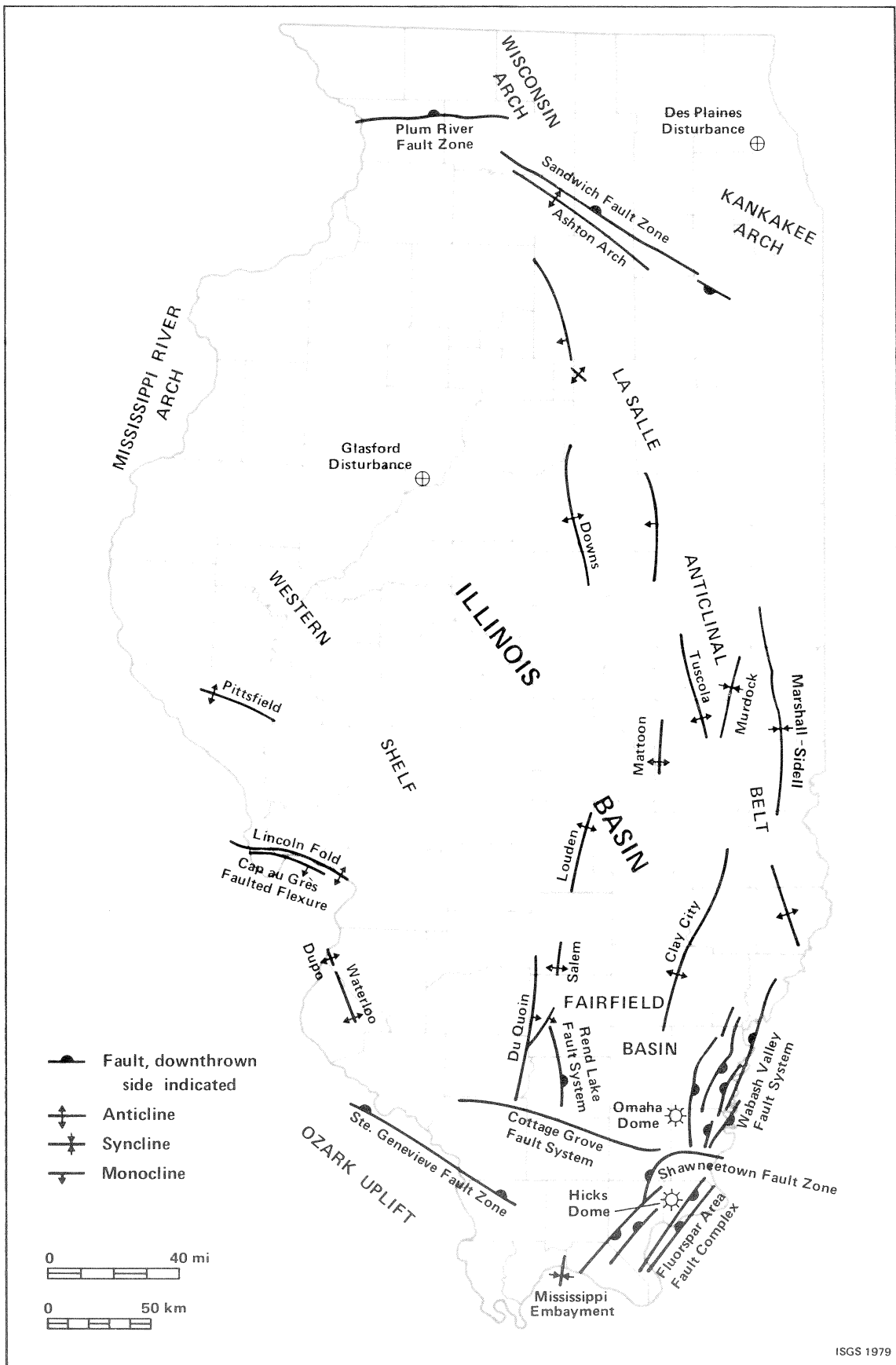

Figure 1. Major geologic structures of Illinois, compiled by Janis D. Treworgy, December 1979.

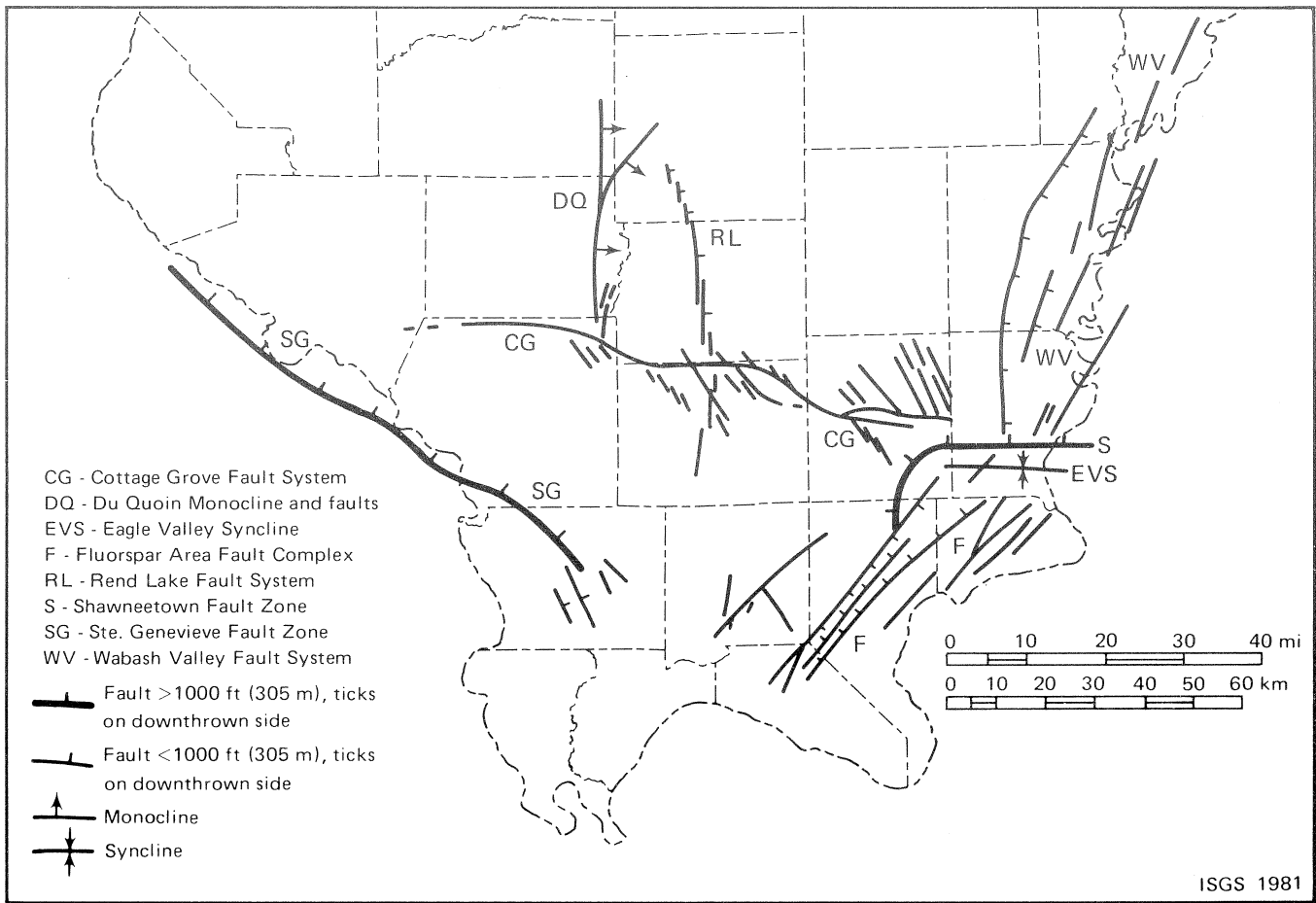

Figure 2. Major fault systems of southern Illinois.

the city of Du Quoin. The monocline has a structural relief of about 300 feet (90 m) down to the east on the Herrin Coal. The east-west dip on the flank of the monocline is 3 to 5 degrees, with much local variation. The monocline marks the boundary between the Western Shelf and the Fairfield Basin to the east (fig. 1).

Along the flank of the Du Quoin Monocline a number of north-south trending faults have been encountered in underground coal mines. These faults are herein named the Dowell Fault Zone (plate 1), for the nearby village of Dowell. They are high-angle normal faults having as much as 40 feet (12 m) displacement. Most of the faults dip to the west, antithetically to the monocline. We believe that the faults of the Dowell Fault Zone are tensional structures directly related to the warping of the Du Quoin Monocline. The Dowell Fault Zone is described in more detail on p. 32.

The Ste. Genevieve Fault Zone (figs. 1 and 2) lies southwest of the Cottage Grove Fault System and trends northwest-southeast, closely following the border of Illinois and Missouri. It is a high-angle fault, with the northeast side downthrown more than 1,000 feet (300 m) in places. Gibbons (1972) considers the Ste. Genevieve Fault Zone to be an upthrust caused by the raising and tilting of blocks in the basement. Heyl (1978, personal

communication) cites horizontal slickensides and low-angle mullion as evidence that significant strike-slip movements occurred along this fault.

Stratigraphic setting

Along the course of the Cottage Grove Fault System the surficial materials consist of unconsolidated Pleistocene glacial till, outwash, and lake deposits; these locally exceed 100 feet (30 m) in thickness, but more commonly are 25 to 50 feet (7 to 15 m) thick (Piskin and Bergstrom, 1975). No indications of faulting in the Pleistocene materials have been reported. Because only small, scattered bedrock exposures—mainly along streams and in roadcuts and surface mines—are available for observation, little opportunity exists to study faults at the surface.

The youngest bedrock units at the surface in the faulted area are the Bond and Modesto Formations of the Pennsylvanian System (fig. 3). These units are composed primarily of shale and lesser amounts of sandstone, several persistent limestone members, and thin coals. Beneath the Modesto is the Carbondale Formation, which includes the Herrin (No. 6) Coal and Springfield (No. 5) Coal Members, the principal seams mined in southern Illinois. Most of the

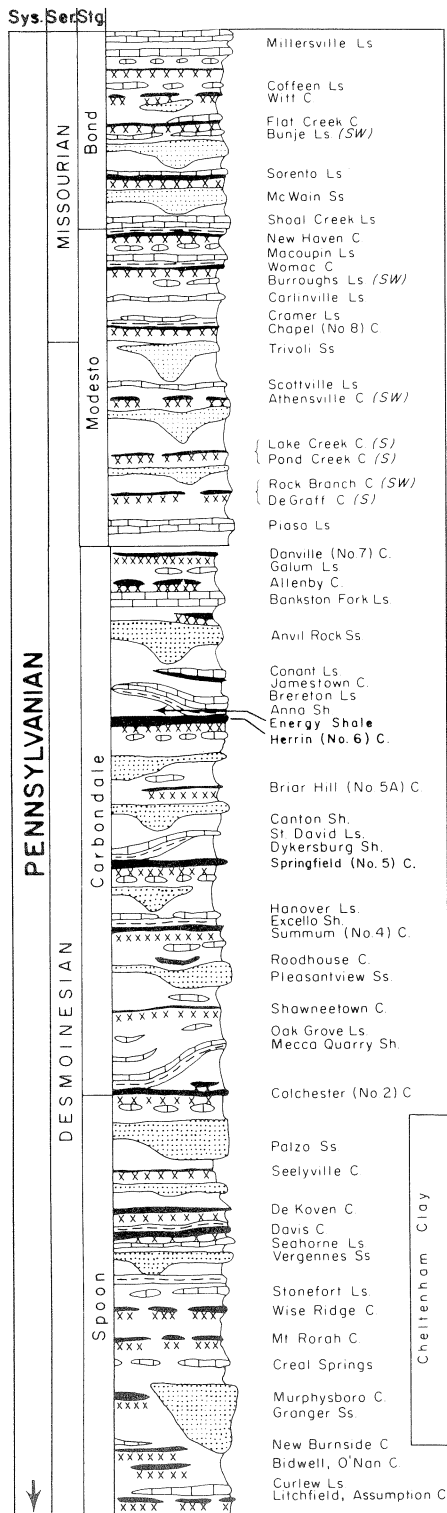
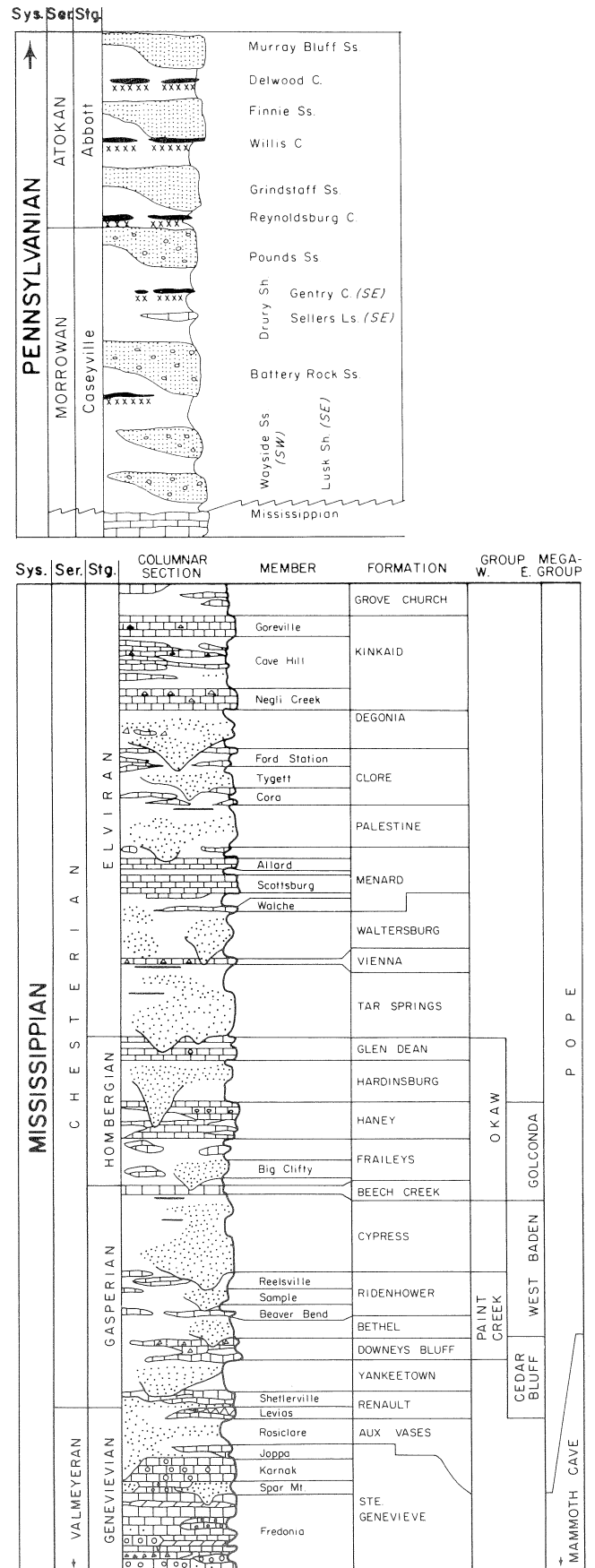

Figure 3. Generalized stratigraphic section of bedrock units along Cottage Grove Fault System. Units below Ste. Genevieve Limestone are rarely penetrated by drilling and are poorly known. Pennsylvanian section (after Willman et al., 1975); Mississippian section (after Swann, 1963).



mining in Saline County has been in the Springfield (No. 5) Coal, although the Herrin (No. 6) Coal primarily is exploited west of Saline County. The maximum depth of the Springfield (No. 5) Coal along the Cottage Grove Fault System is about 500 feet (150 m).

The Spoon, Abbott, and Caseyville Formations compose the lower part of the Pennsylvanian in Illinois. Their total thickness is commonly about 1,200 feet (365 m). The Spoon Formation contains strata of mostly shale and sandstone but includes some thin limestones and minable coal beds. The Abbott and Caseyville Formations consist dominantly of sandstone and minor amounts of shale and rare coal or limestone. A pronounced unconformity exists at the base of the Pennsylvanian System in southern Illinois.

The strata of the upper part of the Mississippian System are assigned to the Chesterian Series. Totaling about 1,000 feet (300 m) in thickness, the Chesterian contains alternating formations of shales, limestones, and sandstone. Several sandstones in the lower part of the Chesterian have yielded oil and gas along the Cottage Grove Fault System. The Chesterian is underlain by the Valmeyeran Series, with the Ste. Genevieve Limestone, 60 to 200 feet (18 to 60 m) thick, near its top. Several sandy and oolitic beds near the top of the Ste. Genevieve Limestone are important hydrocarbon reservoirs. Rarely has drilling along the Cottage Grove Fault System penetrated beneath the Ste. Genevieve Limestone; therefore, the underlying formations are not treated in this report.

STRUCTURE OF THE COTTAGE GROVE FAULT SYSTEM

The main structural components of the Cottage Grove Fault System are:

- (1) The master fault zone—a major east-west trending fault zone.
- (2) Subsidiary faults trending northwest-southeast and branching off both sides of the master fault. Igneous dikes are associated with some of these faults in Saline County.
- (3) A zone of asymmetrical anticlines and synclines trending east-west to northeast-southwest along the master fault zone.

The generalized relationships of these structural components are shown in figure 4.

Master fault zone

The master fault zone includes the largest faults in the Cottage Grove Fault System and is nearly continuous for the entire length of the fault system. Vertical displacements of as much as 200 feet (60 m) have been recorded within the master fault zone. The trend of the master fault zone is generally east-west to east-southeast to west-northwest. At several points along its length the zone branches;

the subparallel components may be as much as 2 miles (3.2 km) apart.

The master fault zone displays repeated "scissoring"; that is, along some segments the throw is down to the north, along other segments to the south. "Scissoring" along a fault is an indication for strike-slip movement. A fault along which mainly vertical movements have occurred ordinarily will show a consistent direction of displacement. However, where a strike-slip fault cuts through strata that are not level, anticlines and synclines will be truncated and displaced opposite one another; this produces frequent reversals of the sense of vertical displacement. This action has been demonstrated in clay models of wrench faulting (Wilcox, Harding, and Seely, 1973).

Where the detailed structural pattern of the master fault zone is known from mines or closely-spaced drill holes, the pattern is very complex. Typically the master fault zone is several hundred feet wide and is characterized by very narrow, steep-sided horsts and grabens. Displacement on individual fault members of the master fault zone often exceeds overall displacement across the fault zone. Apparent normal and reverse faults are found in close association, sometimes joining or intersecting each other. Again, the pattern is best explained as the result of dominantly strike-slip movement. In a fault where the primary movement is horizontal, the fault may appear to be normal at one place and reverse at another. Where several closely spaced, subparallel strike-slip faults occur, the slices of rock between individual faults can be rotated, squeezed up, or dragged down between the walls of the faults.

Detailed maps and cross sections presented in the following pages show the local variations of the structure in the master fault zone along its strike from east to west.

Cottage Township, Saline County. Although the Cottage Grove Fault System was discovered and named in Cottage Township (T. 9 S., R. 7 E.), this easternmost segment of the fault system is still poorly known. To date virtually no coal mining has occurred within the township. Evidence of faulting is provided almost exclusively by shallow holes of coal-test drilling, which locally are very closely spaced but are away from the projected line of faulting. Little additional information has been gained since DeWolf (1907) first published his suspicion of a fault in Cottage Township.

The structure map of the Herrin (No. 6) Coal (fig. 5) indicates a fault trending east-southeast (about 105°*) from the southwest corner of Section 6 to the northwest corner of Section 14, and thence due east to the edge of the township. The southern block is downthrown and the vertical displacement ranges from 65 to 125 feet (20 to 38 m). In Sections 10 and 15, data indicate that the fault may be split, thus forming a lens-shaped horst. An oil well in Section 13 apparently penetrated the fault plane, as indi-

* All compass directions in this report are given in terms of degrees measured clockwise from due north.

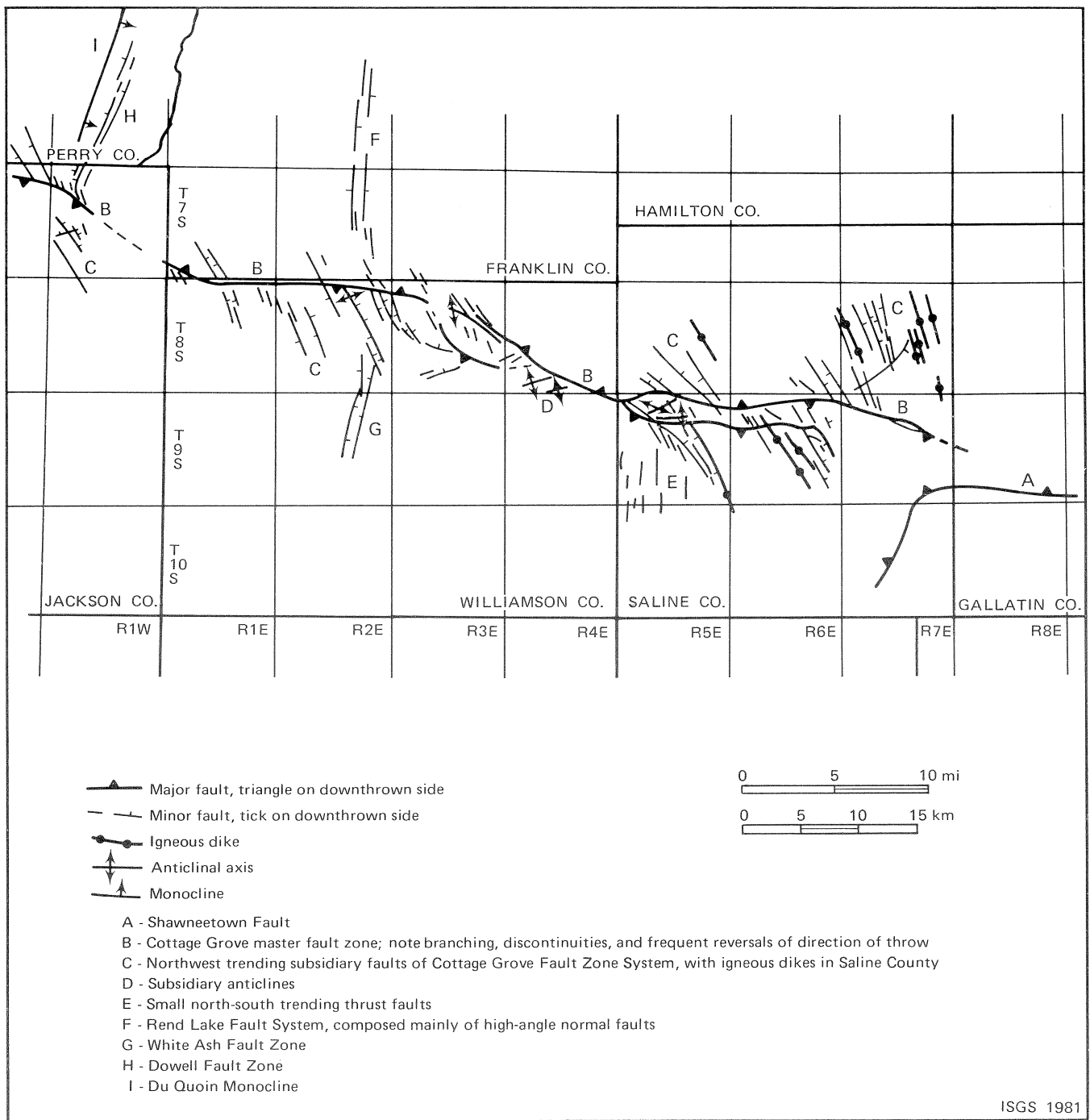

Figure 4. Cottage Grove Fault System and associated structures.

cated by about 72 feet (22 m) of missing strata in the interval between the Kinkaid and Menard Limestones (Chesterian Series).

In the area of most closely spaced drilling, in Sections 9, 10, and 11, the Herrin (No. 6) Coal dips northward at roughly 100 feet per mile (1:50). This inclination is considerably greater than the normal dip of the coal toward the center of the Illinois Basin. The structure is not a normal drag fold, for the sense of folding is opposite to the direction of throw on the fault. Neither does it fit the description

of reverse drag, as published by Hamblin (1965). The fold may be the result of upthrusting within a narrow zone of strike-slip faulting. Other, better-documented examples of upthrusting are shown in figures 38 and 56.

Scanty indications exist of other faults in Cottage Township. The subsurface data indicate either a fault or an abrupt fold trending southwesterly through Sections 14 and 22. Igneous rock was penetrated by oil wells in Sections 2, 25, and 23. The igneous rock may be related to the dikes found farther west in Saline County (p. 24).

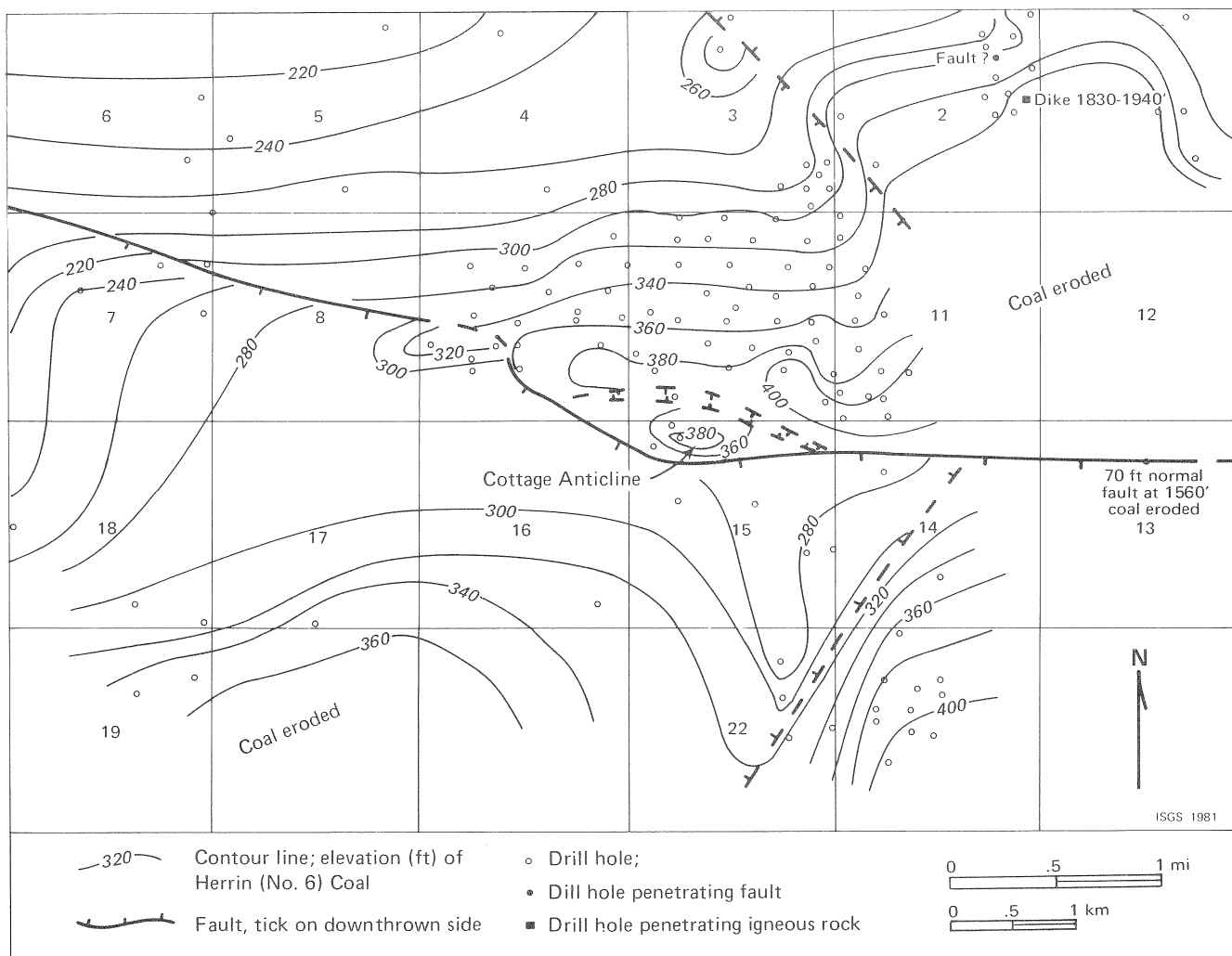

Figure 5. Structure-contour map of Herrin (No. 6) Coal in Cottage Township (T. 9 S., R. 7 E.), Saline County. The master fault can be traced with fair assurance into Section 13, where a drill hole encountered about 70 feet (21 m) of missing strata below the Kinkaid Limestone (Mississippian). Rapid and inconsistent changes in elevation make contouring difficult in spite of high density of data. Igneous rock was struck in a well in Section 2. The crest of the Cottage Anticline lies near the northwest corner of Section 15.

East of Cottage Township the data are inadequate to allow plotting of the Cottage Grove Fault System. Whether or not the CGFS intersects the Shawneetown Fault Zone remains to be demonstrated.

Harrisburg Township, Saline County. The Springfield (No. 5) Coal was extensively mined underground in Harrisburg Township (T. 9 S., R. 6 E.), and the pattern of the Cottage Grove master fault zone has been well defined. The master fault zone appears to be continuous in Harrisburg Township and follows a gently curving east-west course through Sections 1 to 6.

In Sections 1, 2, and 3, the faulting resulted in major vertical displacements. The master fault zone separates the workings of Sahara Coal Company No. 1 and Sahara Coal Company No. 12 Mines. Comparison of elevations of the Springfield (No. 5) Coal on opposite sides of the fault indicates 140 to 150 feet (43 to 46 m) of throw down to the south. No mine entries were driven across the fault zone.

Peabody Coal Company, in Mine No. 43 (East Mine), worked up to the south side of the master fault zone in Sections 4 and 5. Here the throw of the fault zone cannot be determined accurately. Just west of Peabody No. 43 the fault zone undergoes a reversal of displacement. Data from drill holes indicate that the Springfield (No. 5) Coal is downthrown to the north in this area. The electric log from an oil well in the NW¼NW¼SE¼ of Section 5 shows approximately 63 feet (19 m) of missing strata, including the Springfield (No. 5) Coal. This drill hole apparently penetrated a fault. The overall throw may be more or less than 63 feet, because the fault zone may include other faults not penetrated by the drill.

No coal mining has occurred in the northwestern part of Harrisburg Township or the northeastern part of T. 9 S., R. 5 E. because of the presence of the Galatia channel, within which the Springfield (No. 5) Coal is replaced by sandstone and shale. Data from drill holes in Section 6, Harrisburg Township, show decreasing throw on the master fault zone toward the west.

A southern branch of the master fault zone is present in Peabody No. 43 (East Mine) in Sections 7, 8, 9, and 10, Harrisburg Township. This branch lies about 1.1 mile (1.75 km) south of the northern branch and trends parallel with it. The map of Peabody No. 43 (East Mine) shows two parallel, slightly sinuous faults 300 to 400 feet (90 to 120 m) apart in most places. The zone becomes narrower toward the eastern and western ends of the mine. The coal between the two faults was not mined, but in several places ventilation entries were driven through the fault zone. No indication is provided of the direction or amount of displacement on the individual faults, but elevation sightings in the mine show that the overall throw across the fault zone is small. The fact that the coal was not mined between the two faults suggests that the two faults formed either a horst or a graben, within which the coal was displaced a considerable amount up or down.

East of Peabody Coal Company Mine No. 43 the southern branch of the master fault zone splits into a series of northwest-southeast trending en echelon faults in Mine No. 3 of the Sahara Coal Company (plate 1). West of Mine No. 43 data from drill holes indicate a southwesterly dip in the strata along the projected line of the fault. Data are inadequate to reveal whether the fault is continuous across the Galatia channel.

Brushy and Carrier Mills Townships, Saline County. The master fault zone is well defined by extensive mining and drilling in Brushy and Carrier Mills Townships (T. 9 S., R. 5 E.). The two subparallel branches of the fault zone diverge westward and attain a maximum separation of 1.8 miles (2.7 km) in Sections 4 and 9. Thence the two branches converge toward the northwestern corner of T. 9 S., R. 5 E., where multiple faults with as much as 200 feet (60 m) of throw are present.

The northern branch of the master fault is discontinuous in Section 2, where entries of Mine No. 20, Sahara Coal Company, were driven more than 1,000 feet (300 m) north of the projected line of the fault without encountering any east-west trending faults. Two sets of en echelon northwest-trending faults extend through the gap in the master fault zone (fig. 6). These faults are dominantly high-angle normal faults, but some of them show strong indications of strike-slip movement. Details of their structure are presented later (p. 33).

West of Sahara Mine No. 20 the northern branch of the master fault resumes its course and increases in dip slip. A set of entries connecting Peabody Mines No. 43 (West Mine) and No. 47 penetrated a fault with 17 feet (5.2 m) of throw down to the south, along with a number of smaller faults (fig. 6). The coal is inclined rather steeply toward the north through the fault zone. Farther west the master fault zone was left within the barrier of unmined coal between Peabody Mines No. 43 and 47. In most places, the overall throw appears to be down to the north, but some of the apparent offset may be the result of relatively steep

dips in the coal. Both mines butted against faults in several places, but the direction and amount of displacement are not recorded.

The north branch of the master fault zone roughly follows the north line of Sec. 5, T. 9 S., R. 5 E., then bends toward the west-southwest and merges with the south branch of the master fault zone in Sec. 6, T. 9 S., R. 5 E. As the north branch turns, it divides into at least three faults with large vertical displacements. The three faults form a graben 150 to 200 feet (46 to 61 m) deep and a horst with similar displacement. Several drill holes along the fault zone penetrated faults, as indicated by absence or repetition of strata.

The southern branch of the master fault zone trends roughly east-west through Sections 9 to 12, then curves to a heading of about 125 degrees and joins the northern branch in Section 6. The east-west segment of the fault consists of many closely spaced parallel fractures of small displacement, mainly downthrown to the south. The faults follow the south flank of the Brushy Anticline, (see p. 19) along which the coal dips southward at an angle of about 10 degrees. The faults were exposed for study on a set of entries of Sahara No. 20, near the southwest corner of Section 10. There, they were seen to be normal faults, with slickensides trending in dip direction. No indications of horizontal or oblique movement could be found. Such structures indicate a simple lateral north-south extension. Quite possibly these faults formed in reaction to folding along the Brushy Anticline and are not directly part of the master fault zone.

Along the northwest-trending segment of the south branch of the master fault zone, the displacement increases toward the northwest, to a maximum of about 100 feet (30 m) down to the southwest. Data from numerous test holes indicate multiple faults; most are normal faults but there are also some reverse faults. Southwest of the main set of faults is a second parallel fault or set of faults with the southwest side downthrown 60 to 80 feet (18 to 25 m). All the faults appear to merge into a narrow master fault zone near the Saline-Williamson county line.

Crab Orchard Township, Williamson County. The master fault zone crosses Sections 1 and 2, Crab Orchard Township (T. 9 S., R. 4 E.), on a heading of slightly north of west. Data from drilling indicate at least two large faults forming a horst. An oil test in Section 1 penetrated a 72-foot (22 m) reverse fault at a depth of 2,550 feet (777 m), as indicated by a repeated section in the electric log. This fault is probably part of the master fault zone, but whether it directly connects with the faults that offset the coal cannot be determined.

Corinth Township, Williamson County. Data from drilling in Corinth Township (T. 8 S., R. 4 E.) show that the master fault zone strikes 105 to 110 degrees and has a large throw down to the north. The displacement is approximately 100 feet (30 m) along most of the zone, but may be as

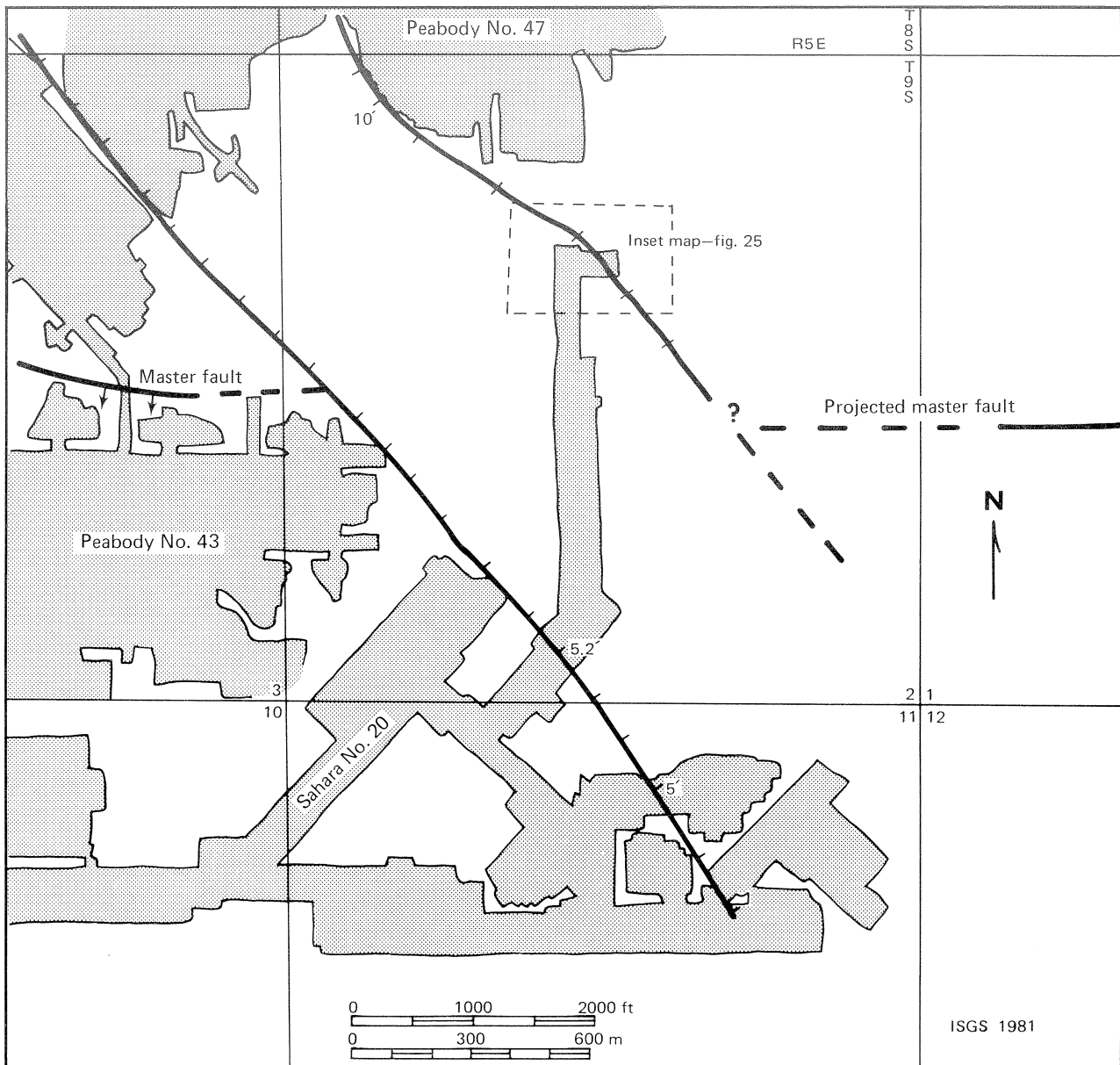

Figure 6. Discontinuous segment of the master fault in T. 9 S., R. 5 E., Saline County. Entries of Sahara Mine No. 20, driven across the projected line of the master fault, encountered no east-west faults but did cross two northwest-trending sets of faults (see "Study Area 1").

great as 200 feet (60 m) in the eastern part of Section 33. Some of the offset may be the result of sharp folding rather than faulting. In Sections 19 and 30, near the Orient No. 4 Mine, the fault zone curves abruptly to a heading of about 135 degrees and begins to decrease in throw. A set of entries in the mine were driven through the fault zone and revealed a steep-sided graben on the flank of a large flexure in the coal. The structure exposed in the mine is complicated and details of it will be discussed later in this report (p. 45).

Lake Creek Township, Williamson County. The master fault zone is discontinuous in Lake Creek Township (T. 8 S., R. 3 E.). The faults exposed in the Orient No. 4 Mine continue northwestward, but bear many features more

characteristic of subsidiary faults than of the master fault zone. These faults extend downward as reverse faults well into the Mississippian strata, as indicated by repeated sections of strata in two oil tests in Section 24. In one hole, 96 feet (29 m) of strata, including the Negli Creek Limestone Member and the Degonia Sandstone (fig. 3), are repeated on a fault at 1,650 feet (503 m). In the other well, part of the Bethel Sandstone appears to be duplicated; this signifies a reverse fault with 70 to 80 feet (21 to 24 m) of throw at 2,650 feet (808 m). One of the faults exposed in the Orient No. 4 Mine is a high-angle reverse fault with 95 feet (29 m) of throw. The two wells may have penetrated the same fault. This fault diminishes in throw toward the northwest and probably terminates in the northern part

of Section 15. A series of northwest-trending, en echelon faults continue several miles beyond into Franklin County. These are typical subsidiary faults and will be described in a later section (see p. 16).

The master fault zone resumes its course in Section 8 and strikes slightly north of west (plate 1). At its eastern end the fault zone splits, and the several branches turn southeastward to become en echelon subsidiary faults. The largest of these faults, and the faults described in the previous paragraph, outline a lozenge-shaped area within which many additional northwest-striking faults have been mapped.

In the western part of Section 8 the master fault zone comprises at least two faults with an aggregate displacement of 50 feet (15 m) down to the north. Farther west the master fault zone lies in the unmined block of coal between two mines, and the amount of offset is uncertain.

Herrin (T. 8 S., R. 2 E.) and Blairville (T. 8 S., R. 1 E.) Townships, Williamson County; and Denning (T. 7 S., R. 2 E.) and Six Mile (T. 7 S., R. 1 E.) Townships, Franklin County. In Ranges 1 and 2 East the master fault zone of the Cottage Grove Fault System closely follows the Franklin-Williamson County line (plate 1). Thus it was called the "county line fault" by many old-time miners. The position and amount of vertical offset of the fault zone are quite well known as a result of observations in mines and information from exploratory drilling.

This segment of the master fault zone displays repeated "scissoring." In Sec. 1, T. 8 S., R. 2 E., the north side is apparently downthrown. At the mine of Cosgrove Meehan Coal Company in Section 2, the south side of the fault zone is downthrown 22 feet (6.7 m). Four miles (6.4 km) farther west, in Sec. 36, T. 7 S., R. 1 E., the north side is again downdropped. At several points along the "county line fault" the Herrin (No. 6) Coal lies at nearly the same elevation on opposite sides of the fault zone.

The master fault zone may be discontinuous in the abandoned workings of Old Ben Coal Company Mine No. 15, Sec. 3 and 4, T. 8 S., R. 2 E. Along the expected line of the fault zone, no large east-west trending faults were encountered. However, large northwest-trending faults and strongly folded coal made mining difficult, and large areas of coal could not be recovered because of structural complexities.

Northwest-striking faults at Old Ben Mine No. 15 have as much as 56 feet (17 m) of vertical offset and, according to sketches made by an engineer who worked in the mine, have nearly vertical planes. Along one of these faults the Herrin (No. 6) and Springfield (No. 5) Coals were in juxtaposition. It is reported that miners followed the latter seam for a considerable distance before realizing they were not in the Herrin (No. 6) Coal that they were supposed to be mining.

A series of test holes in the NW $\frac{1}{4}$ SW $\frac{1}{4}$ of Sec. 3 and the

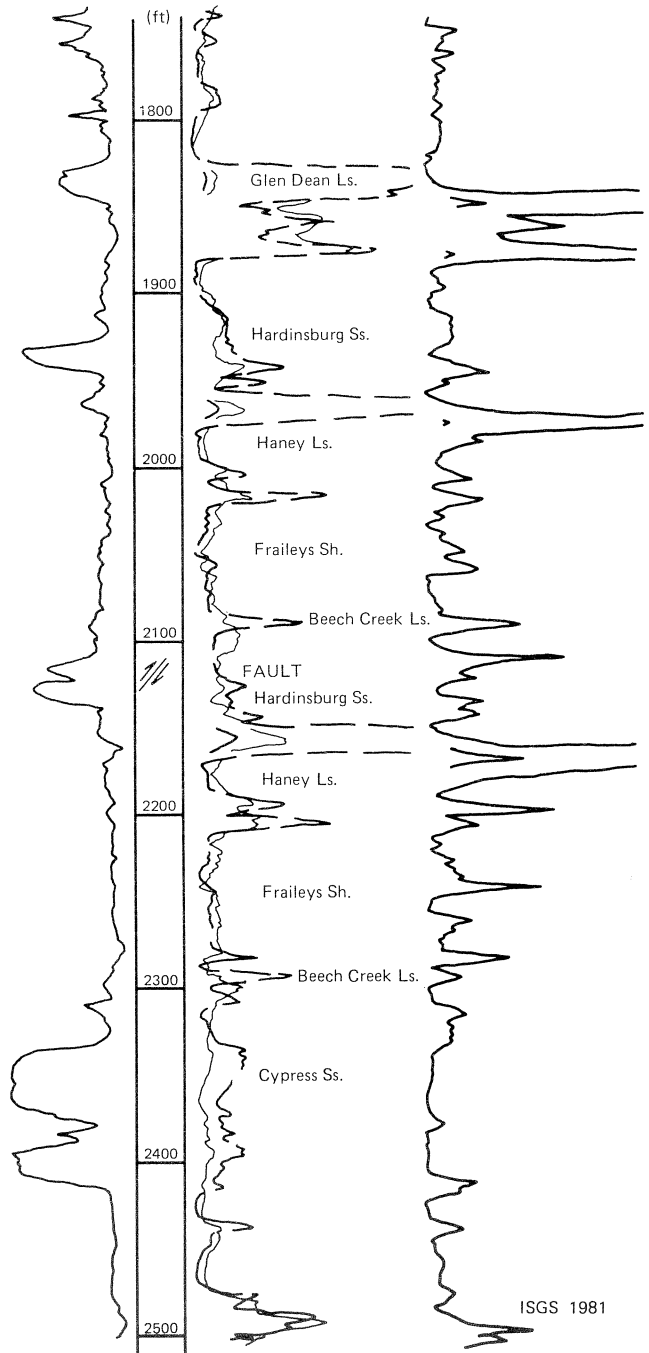

Figure 7. Electric log of oil test in SE $\frac{1}{4}$ SE $\frac{1}{4}$ NE $\frac{1}{4}$ Sec. 4, T. 8 S., R. 2 E., Williamson County, showing approximately 200 feet (61 m) of repetition in the Chesterian strata. A reverse fault at a depth of 2,120 feet (646 m) is indicated. The structure is represented in the Pennsylvanian by an anticline, probably faulted, with over 200 feet (61 m) of closure.

NE¼SE¼ of Sec. 4, T. 8 S., R. 2 E., reveal the presence of an anticline having more than 200 feet (60 m) of relief on the Herrin Coal. At the crest of the fold the Herrin Coal has been eroded beneath the Pleistocene cover. The anticline is probably faulted, but the data are insufficient to locate the faults.

The electric log of an oil test in Sec. 4, T. 8 S., R. 2 E., shows approximately 200 feet (60 m) of repeated section in the Chesterian strata (fig. 7). The log indicates that the well intersected a reverse fault at a depth of 2,120 feet (646 m). The orientation of this fault, and whether it penetrates the Pennsylvanian strata, cannot be determined from the data available.

The master fault zone resumes its westward course in Sec. 5, T. 8 S., R. 2 E., where entries of Franklin County Coal Corporation Mine No. 5 were driven through the fault zone. The map of the mine shows two parallel faults forming a graben about 50 feet (15 m) deep. The coal lies at approximately the same elevation north and south of the graben, but it dips into the graben at inclinations as great as 45 degrees. The graben itself apparently is only about 10 feet (3 m) wide, and it is filled with thoroughly crushed coal and rock (Gilbert H. Cady, 1918, ISGS field notes).

The structure of the fault zone, as described by Cady, strongly suggests strike-slip movement. Figure 8 illustrates how narrow, steep-sided grabens can develop as the result of horizontal movements along a fault. The fault, as initially formed, is not quite planar in map view. As offset occurs, the walls of the fault tend to be ground against each other in some places, while elsewhere the walls diverge to produce open voids. Fractured material from the walls drops into the open voids and may be pulverized by continued movement. The result has the appearance of a narrow graben filled with brecciated material.

Grabens produced by horizontal extensional forces have quite a different structure. These grabens are bounded by normal faults that are inclined inward so that the graben widens upward. The rocks within the graben may be fractured, but are usually not brecciated. The width of the graben often is several times the vertical offset along the normal faults. Examples of extensional grabens are common in the Rend Lake (Keys and Nelson, 1980) and Wabash Valley (Bristol and Treworgy, 1979) Fault Systems.

From Franklin Mine No. 5, the master fault zone continues westward to the southwestern corner of Franklin County, and there it assumes a heading of roughly east-south-east (120°). At least part of the master fault zone is exposed in the workings of Mine No. 2, Western Coal Mining Company, located in Section 31, Six-Mile Township (T. 7 S., R. 1 E.). The fault in the mine has a very small component of dip slip but a wide zone of deformation (up to 20 feet [6 m]) in which the coal and associated strata are folded, crushed, and fractured (fig. 9). The intensity of deformation and the inconsistency of dip slip are evidence for strike-slip movement.

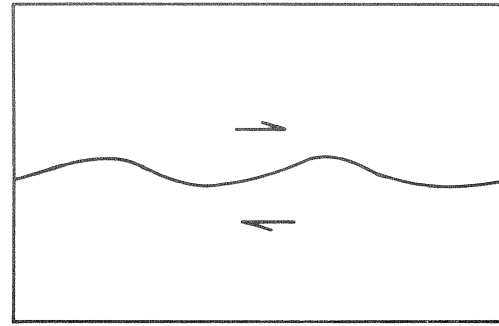

A. Map view of a right-lateral fault with a sinuous plane. Dip of fault plane would also be variable.

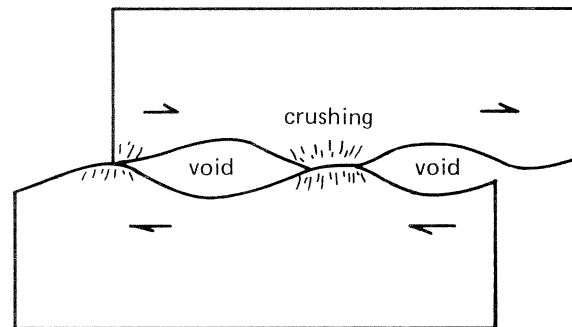

B. Movement along the fault offsets the curves on the fault plane, jamming the rocks together in some places and creating open fissures or voids in other places.

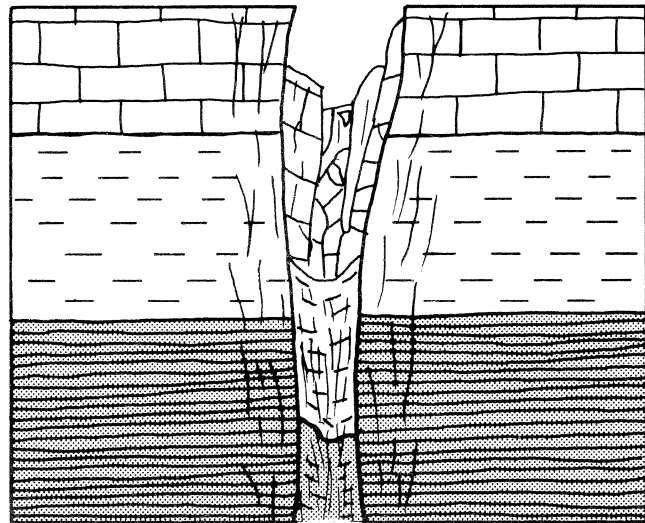

C. Cross-sectional view of fault zone shows how fractured rock on either side of the fault plane could drop into the open void, creating the effect of a narrow, steep-sided graben. Continued movement on the fault will grind these rocks together and allow them to drop farther down along the fault.

ISGS 1981

Figure 8. Illustration of how narrow, steep-sided grabens might develop along a strike-slip fault.

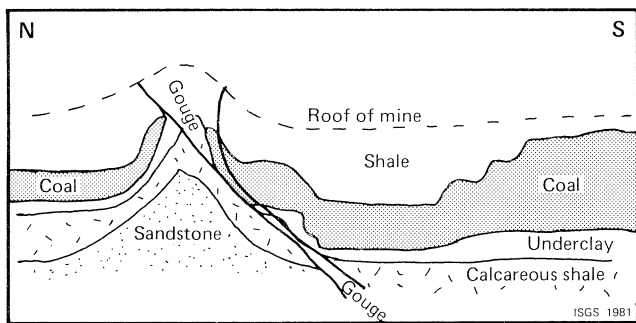

Figure 9. Field sketch of the master fault zone at Mine No. 2, Western Coal Mining Co., in Sec. 31, T. 7 S., R. 1 E., Franklin County. The coal seam is thinned considerably by stretching and is folded into a sharp narrow anticline, being broken off across the crest of the fold. The underlying strata likewise are folded upward in the fault zone. The fault itself is marked by a narrow zone of gouge inclined steeply toward the south. The structure shown in this sketch is best explained as the result of dominantly strike-slip movement. (Sketch by H. E. Culver, unpublished mine notes, 1918.)

Jackson County. In eastern Jackson County, the location and structure of the master fault zone are poorly known because of a scarcity of data from mines and drill holes (plate 1). In the eastern half of T. 7 S., R. 1 W. the Herrin (No. 6) Coal is replaced by shale and sandstone deposited in the Walshville channel. Between Mine No. 2 of the Western Coal Mining Company in Franklin County and the Kathleen Mine of Union Colliery Company in Jackson County, the projected line of the master fault strikes approximately east-southeast (120°).

The main workings of the Kathleen Mine lie northeast of the master fault zone. One set of entries was driven through the fault zone in Sec. 16, T. 7 S., R. 1 W., in order to reach the coal southwest of the fault zone. A profile of the Herrin (No. 6) Coal across the fault zone has been prepared (fig. 10). Data from drill holes indicate at least four major faults, which form a series of horsts. The Herrin (No. 6) Coal has been offset as much as 110 feet (33 m) along individual faults, but the cumulative displacement across the entire zone is only about 70 feet (21 m). A large upward fold of the coal south of the fault zone accounts for most of the difference in elevation across the zone. The detailed structure of the fault zone is not known because no geologists' notes from this part of the Kathleen Mine are available.

Westward from Section 16 the master fault zone continues on a west-northwesterly trend for about 2 miles (3.2 km), then it curves to a westerly heading in Vergennes Township (T. 7 S., R. 2 W.). Closely spaced coal-test drill holes in Vergennes Township indicate a series of subparallel faults with as much as 150 feet (45 m) of vertical offset in the Herrin (No. 6) Coal.

Shaw (1910) shows a fault in northwestern Jackson County on his map of the structure of the "No. 2 Coal" (now recognized as the Murphysboro Coal). The fault extends due west from the center of Sec. 3, T. 7 S., R. 3 W. to Sec. 1, T. 7 S., R. 4 W. (the edge of Shaw's map). The

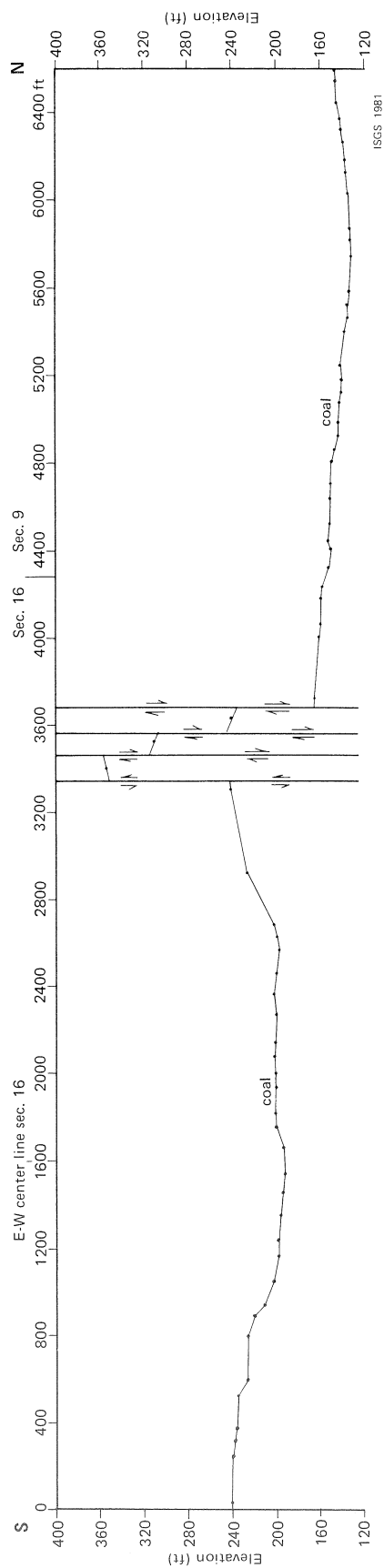

Figure 10. Cross section of master fault zone in Kathleen Mine. This profile is made from mine survey and drill-hole data on the Herrin (No. 6) Coal along the 3rd South off the Main East in the Union Colliery Co. Kathleen Mine, Jackson County. The line of profile runs north-south and lies 1,600 feet (488 m) west of the north-south center line of Secs. 9 and 16, T. 7 S., R. 1 W. Datum points on the base of the Herrin (No. 6) Coal are indicated by dots. The faults strike roughly northwest (135°). No information on dips of fault planes is available. The basic structure is a complex horst flanked by broad synclines on both sides. Although displacements on individual faults may exceed 100 feet (30.5 m), overall vertical offset of the coal seam across the fault zone is small. A large component of horizontal movement probably is present.

Murphysboro Coal is downthrown as much as 200 feet (60 m) on the north side of the fault. The fault lies along the steeply dipping northern flank of an anticline that connects westward with the Campbell Hill Anticline. Shaw's fault probably is the westward continuation of the master fault zone of the Cottage Grove Fault System.

Although evidence (to be presented later in this report) indicates that the Cottage Grove Fault System extends west to the Jackson-Randolph County line, the master fault zone cannot be delineated west of Sec. 1, T. 7 S., R. 4 W. in Jackson County. If the master fault zone is present west of Section 1, it does not have a large enough component of dip slip to be recognizable from the available data.

Subsidiary faults and igneous dikes

General structure. Subsidiary faults with a dominant strike of northwest to southeast are found along the entire length of the Cottage Grove Fault System both north and south of the master fault zone. With the master fault zone, the subsidiary faults form a pinnate or en echelon pattern. The dip slip along subsidiary faults varies from a barely perceptible amount to a maximum known throw of 60 feet (18 m). Because the offset along subsidiary faults is small, these faults are difficult to locate by drilling. Nearly all our knowledge about subsidiary faults in the CGFS is derived from exposures in underground coal mines.

Dikes of basic igneous rock are closely associated with the subsidiary faults in Saline County and eastern Williamson County. These dikes have the same orientation as the faults and, in some cases, were intruded along fault planes; in other cases, the dikes have been offset by later faulting. The dikes have sometimes presented an obstacle to coal mining, because of their hardness and because of alteration of coal adjacent to the dikes.

Subsidiary faults in Saline County. Northwest-trending subsidiary faults are large and numerous on both sides of the master fault zone in Saline County (plate 1). Nearly every coal mine in the county has encountered one or more of these faults. In a number of cases the faults have proven detrimental to mining and have contributed to the premature closing of at least one operation.

Several faults can be traced continuously along strike for several miles. In northeastern Saline County, some subsidiary faults have been mapped as far as 7 miles (11 km) from the master fault zone and show no signs of diminution at the limit of the mined area. South of the master fault zone, some subsidiary faults have been mapped at least 3 miles (5 km) to the edge of mining. The width of the Cottage Grove Fault System in Saline County is therefore at least 10 miles (16 km).

The faults show a definite regional change in the direction of strike. Those in eastern Saline County strike slightly east of south about 165 degrees. Several of the eastern faults are slightly curved along strike, with the southern

portion trending 165 degrees and the northern portion striking 150 to 155 degrees. Farther west in Saline County the faults strike more nearly to the northwest. Near the Williamson County line the faults follow an average heading of about 135 degrees.

None of the subsidiary faults in Saline County can be traced across the master fault zone. Where the master fault zone is discontinuous, as in Sahara Mine No. 20 (p. 10), some northwest-trending faults extend across the projected line of the master fault zone. There were no indications that subsidiary faults have been cut and offset laterally along the master fault. Rather, most subsidiary faults terminate against the master fault. In several instances, especially in western Saline County, subsidiary faults curve as they approach the master fault, so that subsidiary and master faults are nearly parallel where they join.

Nearly all of the subsidiary faults in Saline County are high-angle normal faults. One small reverse fault was noted in O'Gara Mine No. 8 (T. 8 S., R. 7 E.), and a fault in Eldorado Dering No. 2 Mine (T. 8 S., R. 6 E. and 7 E.) reportedly had a vertical plane bearing horizontal slickensides (ISGS, unpublished mine notes). Most faults shown as single lines on mine maps and in plate 1 actually consist of numerous closely spaced parallel or en echelon faults. Commonly a series of faults forms either a graben or a series of steplike blocks in the coal. In most cases the coal is sheared cleanly, with no drag, and the zone of gouge or breccia is very thin. Blocks within a fault zone may be tilted but seldom are folded (ISGS, unpublished mine notes). Subsidiary faults may dip either to the northeast or to the southwest. No consistent pattern in the direction of dip was noted. The measured vertical offset along faults in Saline County ranges up to about 30 feet (9 m). Some of the faults increase in displacement toward the master fault zone, but others decrease.

Two northeast-trending faults have been mapped in T. 8 S., R. 7 E. (plate 1). In the Wasson Coal Company No. 1 Mine, these faults have little or no dip slip, as indicated by surveyed elevations on the coal on opposite sides of the faults. Nevertheless, the faults apparently posed a serious hindrance to mining, as they were left inside pillars of coal except where entries for haulage or ventilation were driven through them. The nature of the problems caused by the faults in Wasson No. 1 Mine is not known.

One of the northeast-striking faults in Wasson No. 1 Mine appears to be offset where it crosses a northwest-trending fault. No details are available, but at least three explanations are possible: (1) The faults were not plotted accurately by Wasson Coal Company; (2) The northwest-striking fault is younger and has a large component of left-lateral slip; or (3) The northeast-trending fault is younger and was interrupted along the discontinuity presented by the northwest-trending fault.

The larger of the two northeast-trending faults extends into O'Gara Coal Company No. 11 Mine, where it was crossed by a set of entries near the southern end of the

mine. There the fault is a normal fault striking NE (50°), dipping 55 degrees to the southeast, and having the southeast side downthrown 21 feet (6.4 m). The zone of drag and gouge is very narrow, and the coal is unfractured within 1 foot (0.3 m) of the fault plane (Netzeband, unpublished field notes). Northeast of these entries the fault was left in the solid pillar of coal between mines. It apparently turns almost to a northerly heading before dying out in Sec. 21, T. 8 S., R. 7 E.

Igneous dikes. Dikes of mica-peridotite accompany the northwest-trending subsidiary faults of the Cottage Grove Fault System in Saline County and southeastern Williamson County. The dikes have been encountered in numerous abandoned underground mines and have been reported in strip mines and in drill cores. Small sills also have been described in underground mines, and some of the intrusive rocks penetrated in test holes may be sills. No igneous rocks are currently accessible in active mines. The dikes and their effect on surrounding coal and rock have been described in detail by Cady (1919), Clegg (1955), and Clegg and Bradbury (1956). In addition, many unpublished notes and sketches of igneous intrusions are found in the Survey's files of mine notes.

All igneous dikes that have been mapped in Saline and Williamson Counties trend parallel with subsidiary faults in the vicinity. Those in mines near Eldorado trend south-southeast (165°). In western Saline County the general direction of strike is southeast (135° to 145°). The Absher Dike in Williamson County trends southeast (140°) (Clegg, 1955).

Almost every igneous dike is accompanied by parallel faults or fractures. In several cases, the igneous rock itself is cut and displaced by faults. Most such faults are normal faults, but one reported by Gilbert Cady (1919, unpublished mine notes) showed possible horizontal movement.

Where dikes penetrate coal seams, the coal in the immediate vicinity is coked and sometimes shows successive zones of alteration and mineralization (Clegg, 1955). In a few cases, coked coal has been reported adjacent to faults that contain no igneous rock (Cady, 1919; Wilson, 1919, unpublished mine notes). This suggests either that molten rock flowed along the fault metamorphosing the coal and then moved elsewhere, or (more likely) that the coal was altered by hot gases or fluids moving along the faults and emanating from nearby intrusives.

The field relationships imply that the igneous rock was intruded during the time of faulting. Extensional faulting in the Cottage Grove Fault System provided northwest-trending fissures along which molten rock was able to rise. In at least some cases, movement in the fault system continued after the dike rock had cooled and hardened, as shown by fracturing and displacement of the dike rock.

Subsidiary faults in Williamson and Franklin Counties. Subsidiary faults of the Cottage Grove Fault System are

less numerous, less extensive, and less uniformly distributed in Williamson and Franklin Counties than in Saline County. The longest subsidiary faults mapped in Williamson County extend about 4 miles (6.4 m) from the master fault, as compared with 7 miles (11 km) in Saline County. Large subsidiary faults tend to be concentrated in narrow, en echelon zones separated by areas having only small and scattered faults. Some of the subsidiary faults have large throws close to the master fault, but the displacements tend to diminish rapidly away from the master fault; this is in contrast to the situation in Saline County, where faults maintain large displacement for many miles.

The pattern of subsidiary faults is not known in most of Corinth Township (T. 8 S., R. 4 E.) where little coal mining has occurred to date. The master fault has been well delineated from drill-hole data, but these data are not adequate to show any of the northwest-trending faults that probably exist.

In contrast, the structural pattern is known in considerable detail in Lake Creek Township and in the extreme western part of Corinth Township (T. 8 S., R. 3 E.), where extensive coal mining has taken place. As has been noted previously, the master fault zone is discontinuous in Lake Creek Township. The eastern segment of the master fault zone dies out in Section 15, and its trend is continued northwestward by a series of en echelon faults that extend as far as Sec. 36, T. 7 S., R. 2 E. in Franklin County (plate 1). The western segment of the master fault zone curves southeastward and splits in Section 8, Lake Creek Township. From this point a complicated series of faults having a variety of orientations extends in a general southeasterly direction toward Section 30, Corinth Township, where they may merge with the eastern segment of the master fault zone.

Many structural details of subsidiary faults in Lake Creek Township are known through exposures in active coal mines. The faults show en echelon patterns in exposures in the mines; this is illustrated well at the scale of plate 1. In most cases a line on plate 1 represents a zone of closely spaced parallel faults and fractures. The zones may be several hundred feet wide, although the major displacements are generally concentrated along much narrower belts. Individual faults rarely can be traced more than a few hundred feet along strike.

Most subsidiary faults and fractures dip steeply, from 60 to 90 degrees. Normal faults are predominant, but most fault zones include a few high-angle reverse faults. Small low-angle reverse faults are rare and occur only in the immediate vicinity of larger high-angle faults. Where large subsidiary faults occur on the flanks of folds, considerable bedding-plane slippage has been observed in the coal and overlying strata. Many northwest-trending faults, especially the largest faults in a given set, show evidence of oblique-slip movement. Horizontal striations and other indications of strike-slip movement have been observed on small faults and fractures near larger northwest-trending faults.

Additional details of many faults in Lake Creek Town-

ship will be presented later (see "Detailed Mapping in Selected Study Areas").

West of Lake Creek Township, where the master fault follows the Franklin-Williamson county line, subsidiary faults are unevenly distributed. The faults tend to be grouped in sets, separated by areas where faults are few and small. Subsidiary faults are noticeably larger and more abundant south of the master fault than north of it. Subsidiary faults south of the master fault have been traced as far as 4 miles (6.4 km) and have displacements as great as 62 feet (19 m). In contrast, no subsidiary faults continue more than 2 miles (3.2 km) north of the master fault or have offsets greater than about 35 feet (11 m).

The average direction of strike for faults in R. 1 and 2 E. is northwest-southeast (145° to 150°). Maps provided by mining companies show that some faults curve slightly or branch along strike. Northeastward and southwestward the faults undergo "scissoring," but interpretation of structure is difficult except where geologist's notes and sketches of the faults are available.

One area where details of the structure are known is in Mine No. 17 of Old Ben Coal Company, in the NE $\frac{1}{4}$ NE $\frac{1}{4}$ Sec. 23, Herrin Township (T. 8 S., R. 2 E.). Cady (1916) presented sketches of a northwest-trending fault zone on opposite ribs of the same mine heading (fig. 11). The sketches reveal a complex structure involving both faults and tight folds in the coal and the overlying shale. The largest fault (marked "main fault" in fig. 11) is a high-angle reverse fault with approximately 28 feet (8.5 m) of throw. East of the fault the coal is folded into a sharp fractured anticline. The dip and displacement of smaller faults changes abruptly. Fault "A" dips to the east on the south rib (upper sketch), but dips toward the west on the north rib (lower sketch). On both ribs Fault "A" is geometrically a reverse fault, with the hanging wall relatively upthrown, but the drag in the coal east of the fault on the north rib is not consistent with the apparent direction of slip. Between Fault "A" and the main fault are several small, tight folds that locally show evidence of shearing along their axial planes. The attitudes of these folds are not consistent with the apparent movements of adjacent faults.

Such a complex structure indicates either that multiple movements occurred, causing wedging and rotation of the blocks between the faults, or that one or more of the faults have a large component of strike-slip movement. Cady (1916) suggested the latter alternative.

Similar conclusions can be drawn about a fault that Gilbert H. Cady sketched in the No. 2 Mine of Western Mining Company in southwestern Franklin County (1918, ISGS unpublished field notes). Cady made two sketches of the same northwest-striking fault (fig. 12). The upper drawing shows the coal and underclay pushed upward and to the west along two curving, low-angle faults. The lower sketch illustrates a vertical fault and a parallel low-angle reverse fault side-by-side, with the block between the faults dropped downward. The coal and shale in the down-

dropped block are slightly crumpled, and the reverse fault shows normal drag. The faults indicate contradictory stress fields: normal faults signify extension; reverse faults, compression; and vertical faults, simple uplift. Again either multiple movements or oblique slippage must have occurred to produce the structure that was sketched.

Cady (1918, unpublished field notes, ISGS) made an interesting observation concerning one exposure of this same fault: "About midway of the bed is a persistent layer of mother coal [i.e. fusain] commonly about 1½ inches thick up to 2 inches and very locally thickens up to a foot or more. The material is apparently a mixture of mother coal and clay. It is very soft [and] can almost be scraped out of the bed in the face." What Cady described may have been a zone of horizontal slippage, along which coal was pulverized and mixed with clay. We have observed in active mines numerous examples of bedding-plane faults having this appearance. These zones of crushed coal can be recognized as faults where they displace earlier vertical faults and fractures (see pages 47 and 52).

Many, if not most, subsidiary faults in the region have simpler structures than those described above. High-angle normal faults and occasional high-angle reverse faults are figured in many field notes and sketches in ISGS files. On these simple faults pure brittle deformation (exemplified by clean-cut fracturing and shearing) is usual; ductile deformation (folding) is rarely seen.

Subsidiary faults in Jackson County. Northwest-striking faults have been mapped both north and south of the master fault zone in northeastern Jackson County (plate 1). Maps of the Kathleen Mine show several such faults, where they extend into southern Perry County. These faults diminish in displacement away from the master fault, and none are known to extend more than 2 miles (3.2 km) from it. South of the master fault zone, northwest-striking faults have been encountered as far as 6 miles (10 km) away from the master fault zone (measured along the strike of the northwest-trending faults). Both high-angle normal faults and reverse faults are represented (ISGS, unpublished field notes). Several faults striking easterly or northeasterly also are shown on maps of abandoned mines south of the master fault zone.

From Sections 8 and 9 in Elk Township (T. 7 S., R. 1 W.) a set of faults extends slightly east of north away from the master fault zone. The north-trending faults are labeled the Dowell Fault Zone on plate 1. The Dowell Fault Zone is not believed to be genetically related to the Cottage Grove Fault System (see p. 32).

Several northwest-striking faults in northwestern Jackson County have been mapped from surficial exposures and drill-hole data. One of these faults, in Section 4, Bradley Township (T. 7 S., R. 4 W.) was estimated to have 45 feet (14 m) of throw at the surface of bedrock (Root, 1928). Although the master fault zone has not been traced this far west, the presence of these northwest-striking faults is a

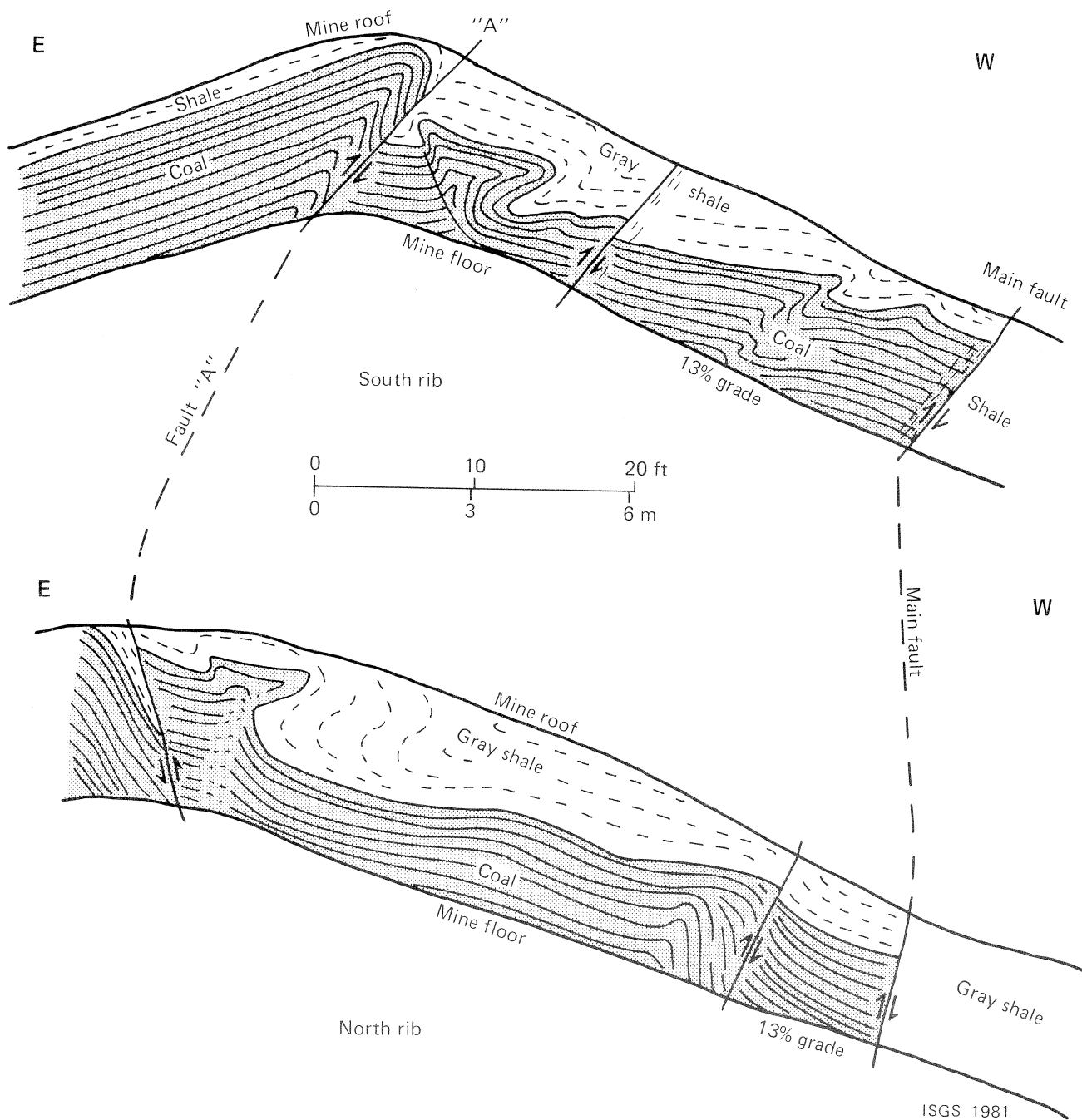

Figure 11. Faults in Old Ben Coal Co. Mine No. 17. Two sketches of the same fault zone on opposite sides of a mine entry. The zone trends southeast (150°) overall and the southwest side is downthrown about 28 feet (8.5 m). The main fault has consistent dip but Fault "A" dips to the east on the south rib (upper sketch) and to the west on the north rib (lower sketch). Fault "A" is a reverse fault on both sides of the entry. In the lower sketch note that the coal east of the fault is folded opposite the direction expected for drag. The geometry of Fault "A" virtually requires a component of strike-slip movement. (Modified from Cady, 1916.)

strong indication that the CGFS extends across northern Bradley Township.

Subsidiary anticlines

Asymmetrical anticlines are found adjacent to the master fault zone along the entire length of the Cottage Grove Fault System. The folds trend parallel or slightly oblique

to the master fault zone and interrupt the regional northward-to-northeastward dip of the coal-bearing strata. Anticlinal limbs facing the master fault zone dip more steeply than limbs opposite the fault. The close geometric association of anticlines with the master fault zone indicates that folds and fault are genetically linked.

Seven of the anticlines in the Cottage Grove Fault System have been named. Three of the names, Cottage,

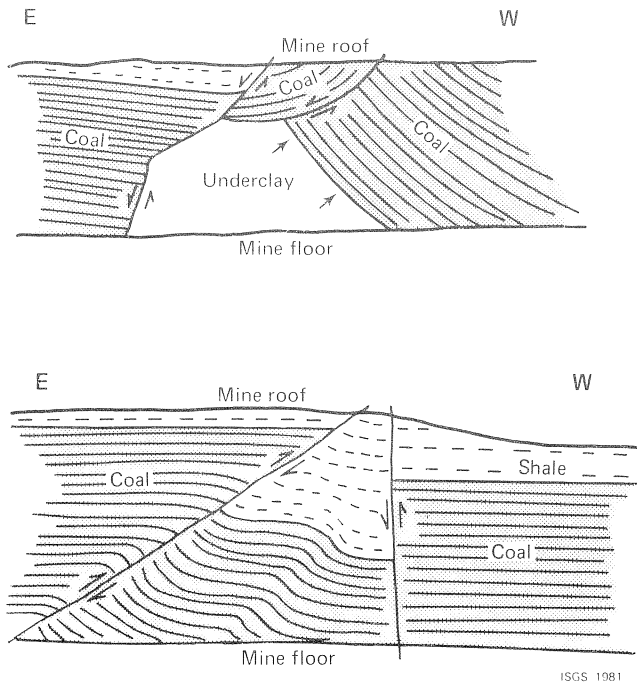

Figure 12. Faults in Mine No. 2, Western Coal Mining Co. Views looking south at two different places along the same NW-trending subsidiary fault. In the upper sketch, fault movement is geometrically normal yet the footwall is strongly folded upward as if by reverse movement. In the lower view, a nearly vertical normal fault and a low-angle reverse fault are parallel and juxtaposed. Such a close association of tensional and compressional features requires either two episodes of faulting and/or a large component of horizontal movement in the fault zone. (Field sketches by Gilbert H. Cady, ISGS mine notes, 1918.)

Pittsburg, and Vergennes, are introduced in this report. The locations of anticlines discussed in the text are shown in figure 13.

The Cottage Anticline. The easternmost anticline in the Cottage Grove Fault System is the Cottage Anticline, named herein for Cottage Township where it occurs. The structure of the Herrin (No. 6) Coal in Cottage Township is illustrated in figure 5. The axis of the Cottage Anticline strikes east-west (90°), slightly oblique to the local trend of the master fault zone (105°). The anticline is strongly asymmetrical, with a gently dipping north flank and a steeply dipping south flank. The master fault zone truncates the southern flank of the fold. Despite densely spaced drilling, the exact relationship of the fold to the fault zone is not known.

The Brushy Anticline. Named by Cady et al. (1939), the Brushy Anticline is a large elongate fold in Brushy Township, western Saline County. The fold lies between the two branches of the master fault zone and strikes parallel with the southern branch (fig. 13). The southern limb of the Brushy Anticline is much steeper than the northern flank. Inclinations of 15 to 20 degrees are common on the southern flank and have locally hindered coal mining. The gently

dipping northern flank has a number of small superimposed domes and depressions that show no apparent pattern of distribution. The Brushy Anticline is penetrated by numerous small faults. Most of the larger faults strike northwestward, but close to the two branches of the master fault zone, a variety of orientations are seen.

Unnamed Anticlines. South of the master fault zone in Corinth Township (T. 8 S., R. 4 E.), Williamson County, two small unnamed anticlines are known from coal-test drilling (fig. 13). The long axes of both anticlines strike 70 degrees, and thus the folds lie en echelon with respect to the master fault zone. Both anticlines are truncated by the master fault zone. No continuation of the folds has been recognized north of the fault zone, either directly across or in offset position.

The Pittsburg Anticline. The Pittsburg Anticline (fig. 14) in Lake Creek Township (T. 8 S., R. 3 E.) of Williamson County is named herein for the village of Pittsburg, which lies just south of the anticline. The axis of the Pittsburg Anticline strikes in a northwesterly to west-northwesterly direction, and the northeastern flank is much steeper than the southwestern flank. The northeastern limb has as much as 200 feet (61 m) of relief in the Herrin Coal, and inclinations of 15 degrees or greater are common. The master fault zone follows the northeastern flank but dies out toward the northwest. In Sections 8 and 9, Lake Creek Township, the anticlinal axis curves to a more westerly heading, and the master fault zone resumes its position along the northern flank of the fold.

The southeastern termination of the Pittsburg Anticline is abrupt. Both the northeastern flank and the south-southeast-facing flank dip at 15 to 20 degrees. The master fault curves to follow the northeastern flank. The south-southeastern limb is broken by a series of east-trending, en echelon normal faults that dip northward (see also p. 35).

The western termination of the Pittsburg Anticline is much more gradual than the southeastward termination. This portion of the fold is cut obliquely by numerous large, northwest-trending faults.

The Vergennes Anticline. The Vergennes Anticline, named in this report for the village and township of Vergennes, lies in northeastern Vergennes Township and northwestern Elk Township, Jackson County. The anticline has been mapped from coal-test drilling in the Herrin (No. 6) and deeper coals (fig. 15). The axis of the fold lies approximately one-half mile (0.8 km) south of the master fault and strikes parallel with the fault on a heading of east-southeast (105° to 110°). The anticline shows roughly 100 feet (30 m) of closure on the Colchester (No. 2) Coal. The dip on the north flank, facing the master fault, is about 1:20. The north flank is truncated by the master fault zone, which in this area has about 100 feet (30 m) of throw down to the north. The southern flank of the Vergennes Anticline is not

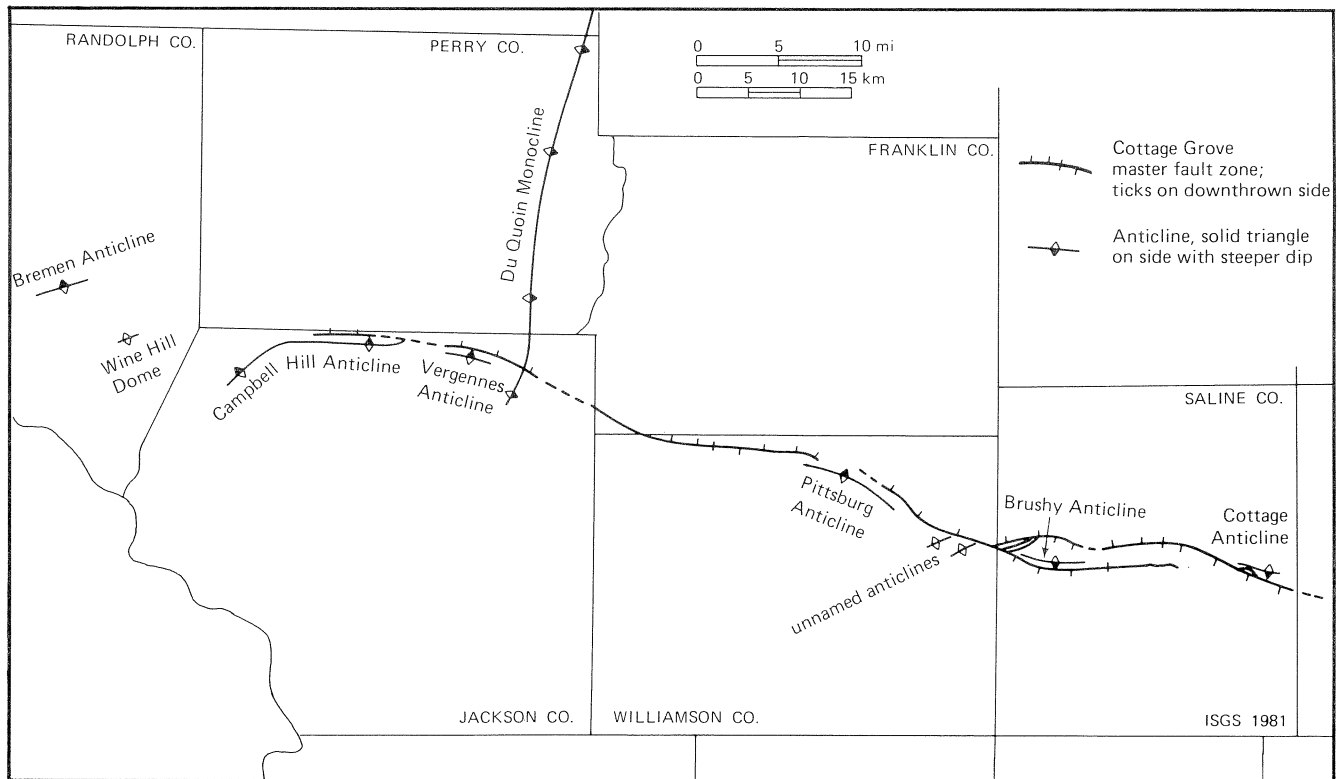

Figure 13. Subsidiary anticlines of Cottage Grove Fault System. Map shows relationship of major anticlines to the Cottage Grove master fault zone. Dip of fault and steeper flanks of anticlines indicated. Note that anticlines (except Du Quoin Monocline) trend parallel with master fault zone or lie in right-handed relationship with master fault zone. Also note that in most cases steeper flank of fold faces the master fault zone. According to Wilcox et al. (1973), Harding (1974), and others this orientation is typical of right-lateral wrench faults.

so steep as the northern flank; the southern flank is inclined about 1:30. The Vergennes Anticline apparently includes strata as deep as the Devonian. Oil is being produced from Devonian limestone in the Vergennes oil field, which lies across the crest of the fold.

The Campbell Hill Anticline. The Campbell Hill Anticline (Root, 1928) lies mainly in Bradley Township (T. 7 S., R. 4 W.) of Jackson County (fig. 16). The axial trend of the anticline is east-northeast (60°), curving to an easterly heading in Section 12. Shaw (1910) mapped the east-trending anticline as continuing as far as Section 4, Vergennes Township (T. 7 S., R. 2 W.; see fig. 13). If Shaw's extension is accepted, the Campbell Hill Anticline is approximately 15 miles (24 km) long. Shaw's map is based on scanty subsurface data on the Murphysboro Coal. Mapping on the Beech Creek Limestone (Mississippian), however, has not revealed any east-trending continuation of the Campbell Hill Anticline beyond Sec. 12, T. 7 S., R. 4 W., (Howard Schwalb, ISGS, personal communication).

The Campbell Hill Anticline lies south of the master fault zone of the Cottage Grove Fault System. In northwestern Ora Township (T. 7 S., R. 3 W.), where the position of the fault zone is well known, the fault zone lies 0.5 to 1.0 miles (0.8 to 1.6 km) north of the crest of the fold. Dips on the northern limb of the fold are considerably

steeper than dips on the southern limb (fig. 16). The anticline may have as much as 300 feet (90 m) of closure on the Herrin (No. 6) Coal (Root, 1928). Both the eastern and western terminations of the anticline are gradual.

As previously mentioned, several northwest-striking faults have been mapped on and near the Campbell Hill Anticline. Most of these faults lie north of the anticline near the projected line of the master fault zone. The faults apparently are typical subsidiary faults of the Cottage Grove Fault System.

The Wine Hill Dome. The Wine Hill Dome is a small structure mapped by Root (1928) on the basis of drill-hole data in Sections 4 and 5, Wine Hill Township (T. 7 S., R. 5 W.), Randolph County. The dome is a slightly elongate structure whose long axis trends slightly north of east and is less than 2 miles (3 km) long. Root mapped a possible fault striking about 110 degrees and having the south side downthrown along the south flank of the dome (fig. 16).

The Bremen Anticline. The Bremen Anticline was mapped from outcrops by Weller (1915) and remapped in more detail by Kay (1916). This fold lies about 4 miles (6.4 km) northwest of the Wine Hill Dome and its axis strikes 70 degrees, so the dome and anticline are en echelon (fig. 13). The southeast flank of the Bremen Anticline dips very

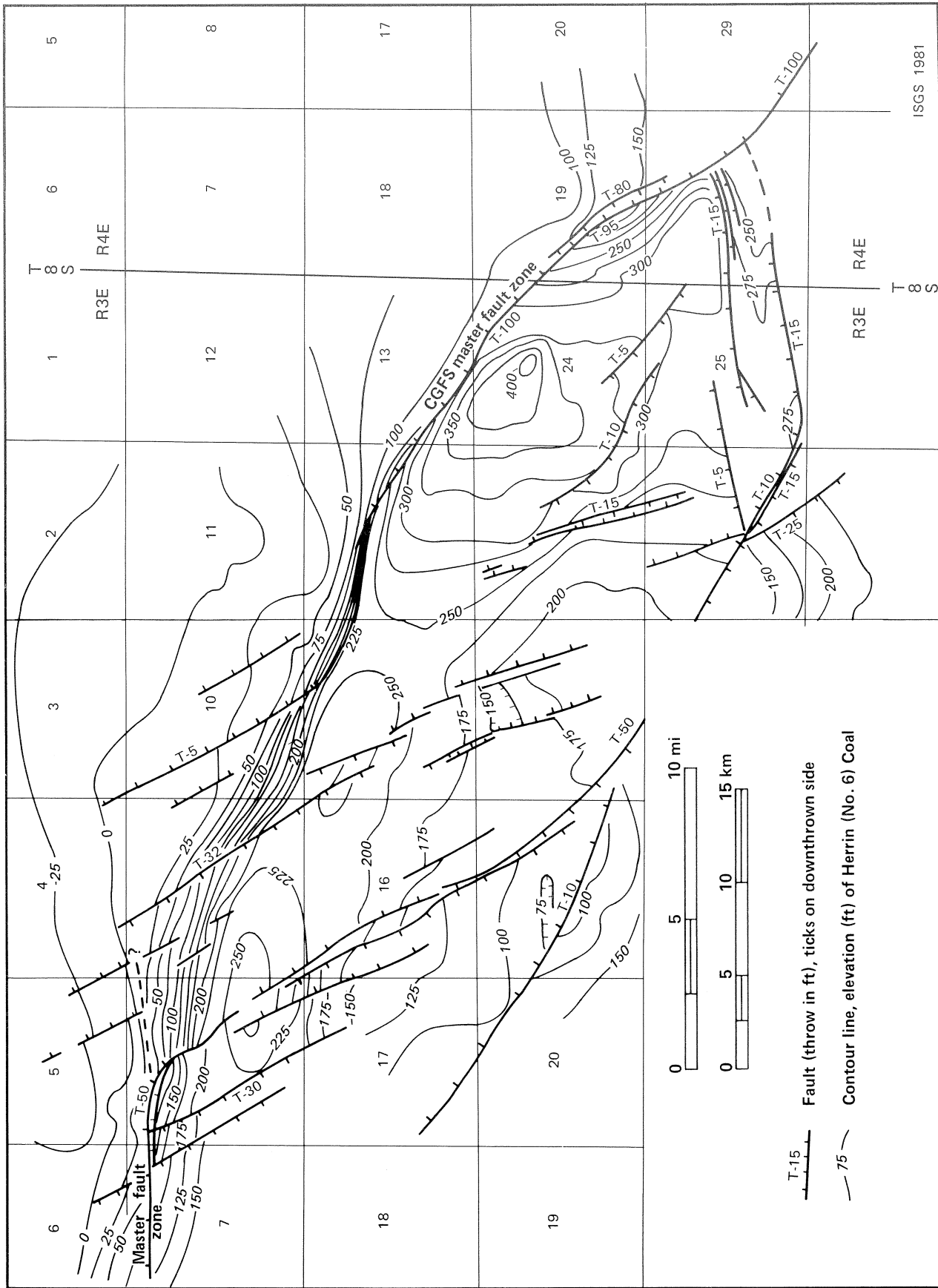

Figure 14. Pittsburg Anticline, contoured on Herrin (No. 6) Coal. Anticline lies just southwest of and parallel with the master fault zone. The anticlinal flank facing the fault zone is much steeper than the opposite flank. The master fault zone is discontinuous in Sections 8, 9, 10, 14, and 15. The Pittsburg Anticline is broken by numerous northwest-trending subsidiary faults.

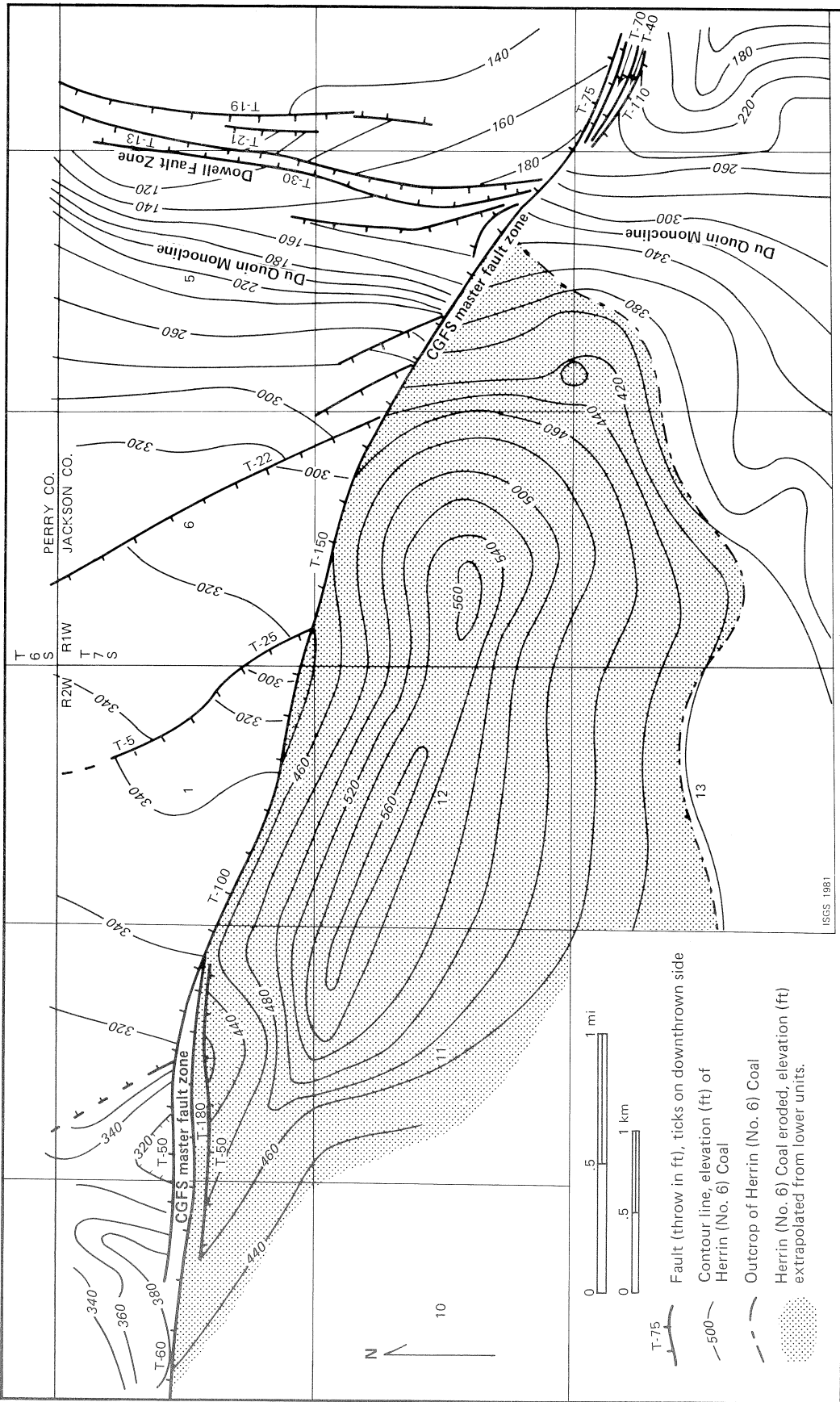

Figure 15. Vergennes Anticline contoured on Herrin (No. 6) Coal. Vergennes Anticline lies parallel with and south of the master fault zone. DuQuoin Monocline and Dowell Fault Zone are seen on east side of map. The monocline crosses the master fault zone and begins to die out about one mile (1.6 km) to the south.

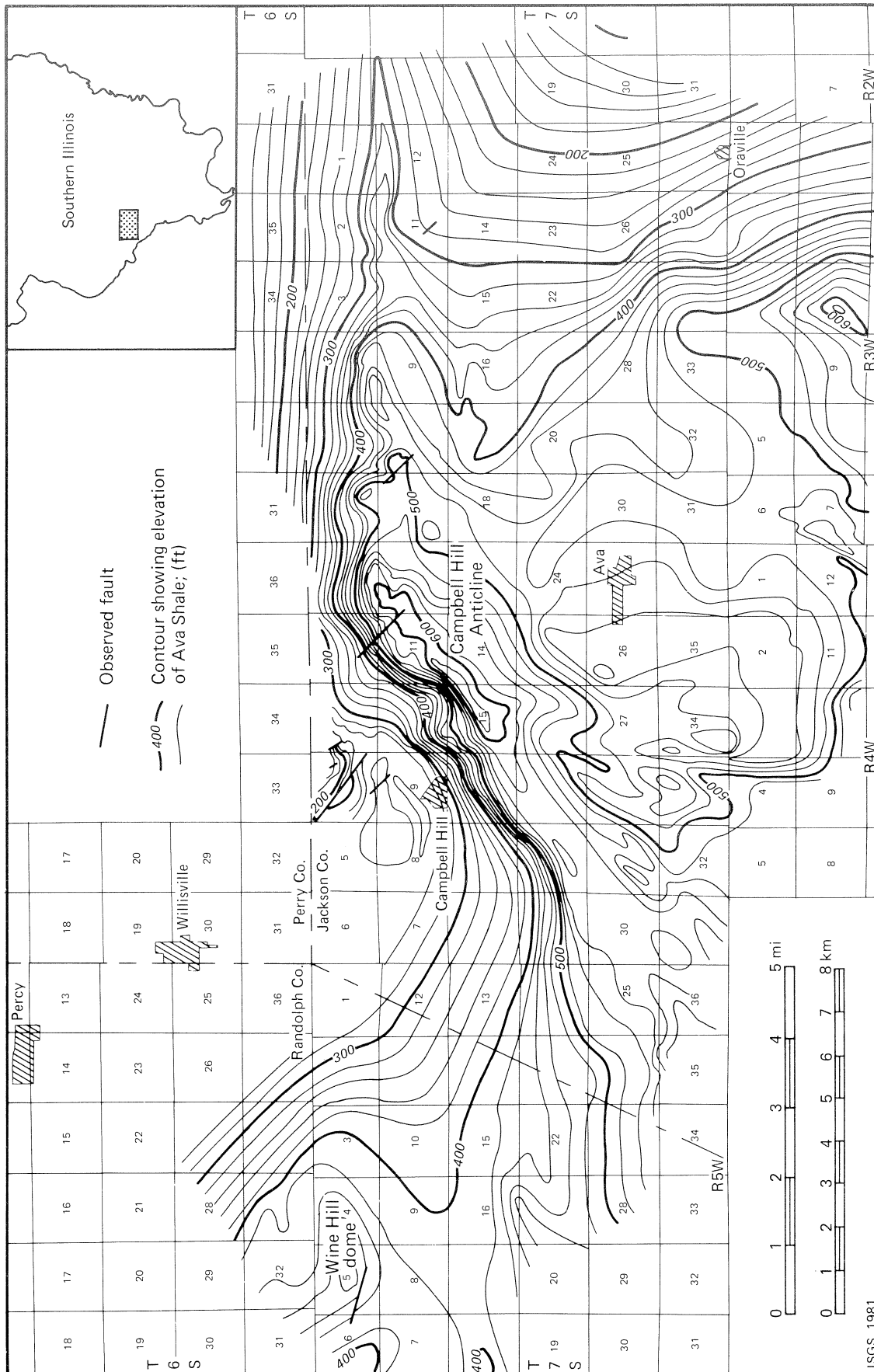

Figure 16. Campbell Hill Anticline and related structures. (From Root, 1928.) Note NW-trending faults along the steep north flank of the fold near Campbell Hill Anticline. The WNW-trending fault near the Wine Hill Dome is inferred from drill hole data. Contours on the "Ava Shale," a local marker bed about 100 feet (30 m) below the Colchester (No. 2) Coal.

gently, about 2 degrees; but dips on the northwest flank are as high as 13 degrees (Kay, 1916). Gilbert Cady (1921, unpublished field notes) recorded a local dip of 45 degrees on one outcrop along the northwest flank in the southwest quarter of Sec. 22, T. 6 S., R. 6 W. If accurate, Cady's observation probably signifies the proximity of a fault.

The Wine Hill Dome and the Bremen Anticline both lie in line with the master fault and have the characteristic orientation of folds in the Cottage Grove Fault System. The possible fault on the Wine Hill Dome and the steep dips on the north flank of the Bremen Anticline further suggest continuation of the fault system into Randolph County. Nevertheless, such an interpretation must be made cautiously, because the data in this region are so scanty. Furthermore, the structural pattern east of Wine Hill Dome (fig. 16) provides no evidence for continuation of the master fault zone there.

ORIGIN OF THE COTTAGE GROVE FAULT SYSTEM

Both the regional structural pattern and the small-scale deformational structures observed in mines lead us to support the contention of Heyl and Brock (1961) that the Cottage Grove Fault System is a zone of right-lateral wrench faulting. The structures mapped in Pennsylvanian strata probably are the result of recurrent movements along an east-west trending, right-lateral strike-slip fault in the basement. Our findings are supported by theoretical considerations, laboratory experiments, and comparison with other fault systems where right-lateral slippage has been proven.

The distribution of stresses and the resulting deformational structures associated with right-lateral wrenching are illustrated in map view in figure 17. The pattern of stresses prior to wrenching can be represented by a circle. With the onset of east-west trending, dextral shearing, the circle is deformed into an ellipse. The long axis of the ellipse is oriented in the direction of maximum extension, northeast to southwest, and the short axis, of maximum compression, runs northwest to southeast. The resulting faults and folds are shown (fig. 17). The ellipse is bisected from east to west by a single right-lateral strike-slip fault. Normal faults are oriented northwest to southeast, perpendicular to maximum extension. Anticlines and thrust faults trend northeast to southwest, at right angles to maximum compression.

The structural pattern of the Cottage Grove Fault System is in fundamental agreement with this theoretical model. The east-west trending master fault zone of the Cottage Grove Fault System shows evidence of strike-slip movement. The northwest-trending subsidiary faults are dominantly high-angle normal faults, this indicates maximum extension along a northeast-southwest axis. Several of the anticlines in the Cottage Grove Fault System are

elongate from southwest to northeast, in conformity with the theory.

A number of discrepancies between the theoretical and observed structural pattern can be resolved by regarding strike-slip faulting as an incremental process that may attain several stages of development. When subjected to a gradual build-up of stresses, most rocks respond first by ductile behavior (folding), then by extensional fracturing, and lastly by compressional fracturing (Thomas, 1974). Thus, northeast-striking anticlines probably were the first features to develop in the Cottage Grove Fault System. Northwest-trending extensional (normal) faults formed next; meanwhile, the anticlines began to be dragged so that their axes turned more nearly east-west. (Note the Campbell Hill Anticline. Its southwesterly portion strikes east-northeast (60°), but its easterly segment, adjacent to the master fault zone, strikes east-west.) The master fault zone was the last major structural element to be formed, and it was not developed as a continuous feature. Neither did the stresses continue long enough to shear the limbs of

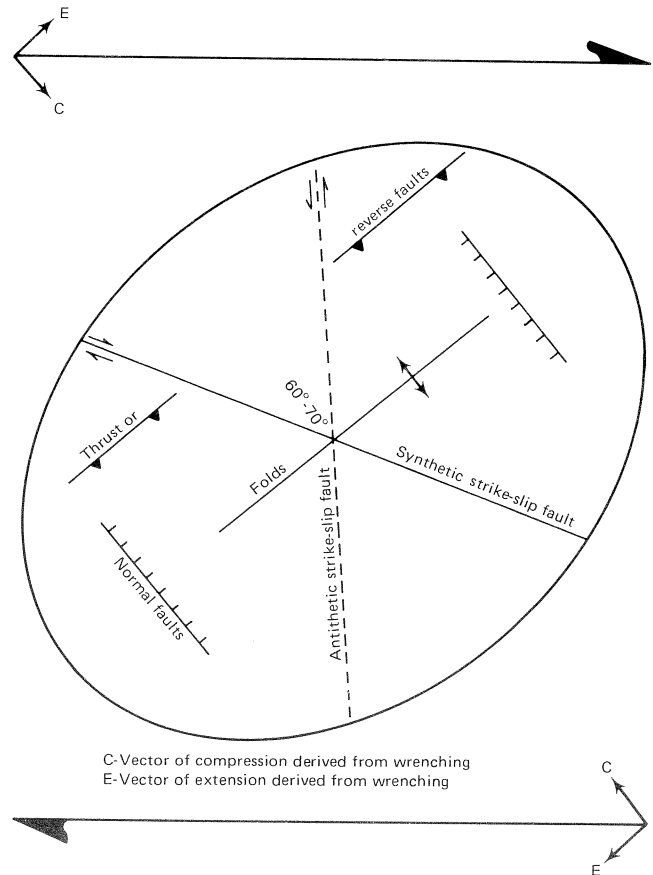

Figure 17. Strain ellipse for right-lateral faulting. Dextral shearing deforms a circle to an ellipse with the long axis oriented northeast-southwest. Resulting structures include (1) right-lateral strike-slip fault trending WNW-ESE; (2) subsidiary normal faults trending NW-SE; (3) anticlines and thrust faults trending NE-SW; (4) antithetic left-lateral faults oriented north-south. All of these structures, with the exception of the thrust faults and antithetic left-lateral faults, are well represented in the Cottage Grove Fault System. (From Harding, 1974.)

anticlines and produce the northeast-striking thrust faults shown in figure 17. Most rocks are much stronger in compression than in extension, so much higher stresses are required to form thrust faults than to produce normal faults or extensional fractures.

Studies with clay models show that precisely the above sequence of deformation occurs in strike-slip faulting. In these experiments, first performed by Cloos (1928) and Riedel (1929), two horizontal plates are slowly moved past one another to simulate strike-slip movement along a fault in the basement. Layers of clay placed upon the plates represent sedimentary strata. With the initiation of slippage, the first structures to be formed in the clay are small folds, which form an en echelon pattern directly above the line of shearing. In the case of right-lateral movement, the anticlines form a right-handed set (fig. 18A) and at first make an angle of about 30 degrees with the line of movement (Wilcox, Harding, and Seely, 1973). With continued movement the folds are dragged until they strike nearly parallel with the line of movement (fig. 18B). At the same time the extensional fractures begin to develop. Like the folds, the fractures form an en echelon pattern, but left-handed in the case of a right-lateral fault. As movements continue, the zone of principal shear becomes narrower, and eventually (fig. 18C) a through-going master fault zone appears (Wilcox, Harding, and Seely, 1973). The master fault zone may consist of a single fault, two or more parallel faults (Wilcox, Harding, and Seely, 1973), or a braided network of faults (Tchalenko, 1970). Once the master fault zone becomes continuous, nearly all further stresses are relieved by slippage along it, and no more subsidiary faults or folds are formed (Tchalenko, 1970).

The Cottage Grove Fault System exhibits structural similarity with many known strike-slip faults around the world. For example, a series of right-handed, en echelon anticlines occurs along the San Andreas Fault in California (Moody and Hill, 1956). That the San Andreas is a right-lateral fault is abundantly clear from offsetting of modern drainage, fences, roads, etc. Right-handed folds occur along several other right-lateral faults in California, including the Inglewood, Calaveras, and Hayward Faults. The axes of nine anticlines along the Inglewood Fault are inclined at an average angle of 13 degrees to the fault (Moody and Hill, 1956).

En echelon folds are found along strike-slip faults in many other parts of the world. The Barisan Mountains Fault in Sumatra, the El Pilar Fault in Venezuela, and several branches of the Alpine Fault in New Zealand all illustrate the association of right-handed folds along right-lateral faults. The folds along left-lateral faults, such as the Dead Sea Rift, are arranged in left-handed sets (Wilcox, Harding, and Seely, 1973). The structures of these fault systems are known in detail because many of the anticlines provide structural traps for major oil fields, which have been intensively drilled.

The development of subsidiary en echelon faults in

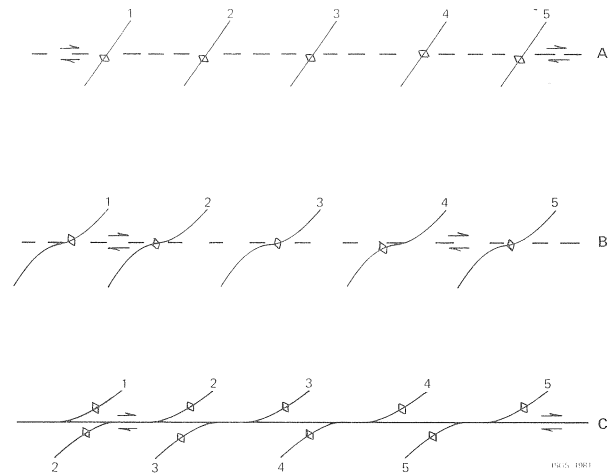

Figure 18. Development of en echelon folds. (A) Right-handed en echelon folds formed in early stages of right-lateral wrenching. (B) Continued wrenching drags the axes of the folds so they trend nearly east-west. (C) Fold axes offset by movement along through-going master fault in final stages of wrenching. The same sequence is observed for left-lateral wrenching except that the folds are left-handed, i.e. they trend NW-SE in an east-west fault zone.

zones of strike-slip movement also can be illustrated by numerous examples. The Cottage Grove Fault System has a pattern of fractures remarkably similar to that of the Osburn Fault, in the Coeur D' Alene District of Idaho (Heyl, 1972). The Osburn Fault trends slightly south of east and shows about 15 miles (24 km) of right-lateral displacement (Hobbs and Fryklund, 1968). Numerous west-northwest to northwest trending faults occur on both sides of the Osburn Fault, especially on the south side. These subsidiary faults dip steeply and show normal, reverse, and strike-slip movement. Dikes of diabase have intruded along some of the faults, and in some cases the diabase has been sheared by later movements. Mineralization of silver, copper, lead, and zinc is concentrated along 12 belts or shear zones that strike parallel with the subsidiary faults. The major mineralization is believed to have occurred before and during the initiation of strike-slip movement (Hobbs and Fryklund, 1968).

A multitude of en echelon fractures was produced at the surface during the Dasht-e Bayaz Earthquake in east-central Iran, August 31, 1968. The fractures were formed along the main east-trending fault, which underwent 2.0 to 4.5 meters (6.6 to 14.6 ft) of left-lateral displacement during the quake, as shown by offsetting of fences and drainage ditches. The subsidiary fractures form a right-handed pattern, opposite to that of the CGFS. Their inclination to the main fault generally is 15 to 30 degrees. They are high-angle extension fractures, having dip slips of a few centimeters at the most. In some cases the fractures have roughly equal components of dip slip and left-lateral strike slip (Tchalenko and Ambraseys, 1970).

At one point the master fault of the Dasht-e Bayaz system becomes discontinuous and jogs toward the north-

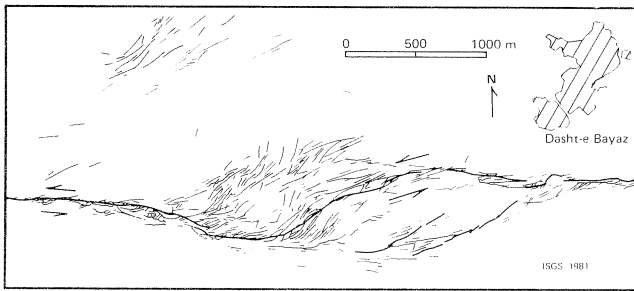

Figure 19. Pattern of ground fractures resulting from left-lateral slip during the Dasht-e Bayaz earthquake, Iran. Basic structure consists of an east-trending left-lateral fault with several meters of displacement, and innumerable northeast-trending subsidiary fractures. In the segment of the fracture zone depicted above, the major faults outline a lozenge-shaped area of intensified tensional fracturing. The pattern is very similar, in mirror-image, to that of the Cottage Grove Fault System in eastern Williamson County. (Reprinted by permission of the Geological Society of America and Tchalenko and Ambraseys, 1970.)

east (fig. 19). The major displacements outline a lens- or lozenge-shaped area, within and adjacent to which the northeast-trending subsidiary fractures are intensified. The pattern of fractures in this area is highly similar to a mirror image of the Cottage Grove Fault System in Range 3 E., Williamson County (plate 1).

At the eastern end of the Dasht-e Bayaz fracture zone the master fault again becomes discontinuous (fig. 20), but subsidiary fractures continue to be prominent in the zone of movement. Also found are a number of fracture zones with an average orientation of north-northeast (23°) and exhibiting right-lateral movement. Thus they make an angle of approximately 60 degrees with the primary fault and exhibit the opposite sense of movement. Faults with this orientation and sense of movement are predicted by both theoretical and experimental models of wrench faulting and are variously called antithetic faults (Harding, 1974), conjugate Riedel shear (Tchalenko and Ambraseys, 1970) or second-order faults (Moody and Hill, 1956). Not all natural strike-slip fault systems contain well-marked second-order faults. Few structures that can be assigned to this category are known in the Cottage Grove Fault System.

Several examples of sets of en echelon faults, not associated with a surficial master fault zone, are known in the United States. A number of such systems have been mapped in Montana. The Lake Basin Fault Zone, a series of right-handed faults near Billings, Montana, shows the pattern best. Wilcox, Harding, and Seely (1973) and Thomas (1974) proposed that the Lake Basin faults are the surficial expression of slippage along a left-lateral fault in the basement. In north-central Oklahoma there are several north-trending belts of en echelon, northwest-trending normal faults. Associated with the faults are north-striking belts of anticlines and a series of buried Precambrian knobs known as the Granite Ridge. Fath (1920) and Foley (1926) attributed the faults and anticlines to left-lateral slippage along north-trending faults in the basement. Sherrill (1929)

proposed that movement in the basement might not be involved, but rather torsional stresses set up by differential uplift and subsidence of gently dipping beds.

We are not certain whether faults of the Cottage Grove Fault System extend into the Precambrian, but two considerations lead us to believe that they do. The first is that individual faults show no indications of downward diminution. A number of drill holes have intersected faults in Mississippian strata as deep as 2,200 feet (670 m) below the level of the coal mines. These faults display the same magnitude of vertical offset as is shown on nearby faults in the coal. A structure map of the Renault Limestone (fig. 21) at the base of the Chesterian Series in Williamson and Franklin Counties indicates the master fault zone in nearly the same position as it is found in the coal. The fault zone has as much as 200 feet (61 m) of dip slip in the Renault Limestone and appears to be continuous throughout the mapped area. Very few wells along the fault system have penetrated below the Ste. Genevieve Limestone (fig. 3), so nothing is known of the character of the system at greater depth.

The other evidence that Cottage Grove faults penetrate the basement is the presence of igneous dikes along faults in Saline County. Indeed, the ultrabasic material of the dikes suggests that the magma ultimately derived from the earth's mantle. We believe (see p. 16) that faults and dikes are contemporaneous; we assume that molten material from deep in the basement moved upward along the extensional subsidiary fractures as they were developing.

One might question whether any arrangement or sequence of stresses, other than right-lateral shear, could account for the observed structural pattern of the Cottage Grove Fault System. The repeated "scissoring" of the master fault and the frequent parallelism of (geometric) normal and reverse faults rules out any interpretation of the system as the result of a single episode of uplift, extension, or compression without wrenching movement. However,

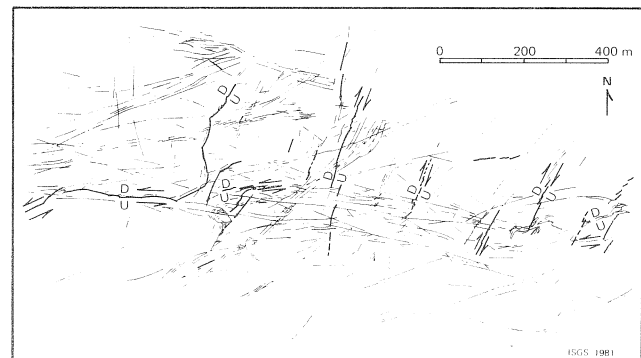

Figure 20. Pattern of ground fractures near eastern end of Dasht-e Bayaz fracture zone. The "master fault" becomes discontinuous, and most of the stress has been relieved through right-lateral slippage along NNE-trending conjugate faults. While the Cottage Grove Fault System contains no direct analogies, small conjugate strike-slip faults have been observed in coal mines (see fig. 51). Reprinted by permission of the Geological Society of America and Tchalenko and Ambraseys, 1970.)

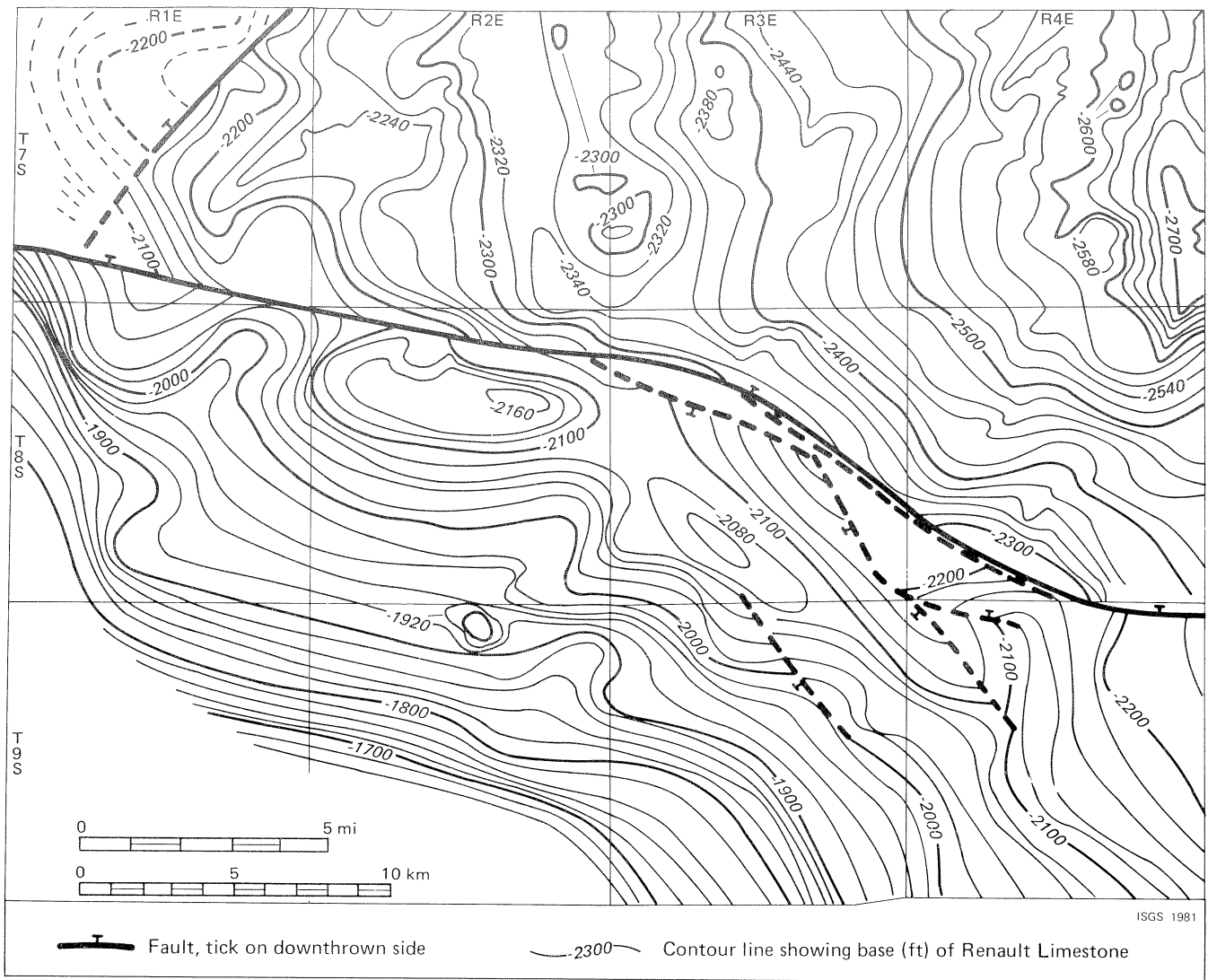

Figure 21. Structure-contour map of base of Renault Limestone (Mississippian) in part of Franklin and Williamson Counties. The master fault zone is well delineated and locally shows 200 feet (60 m) of vertical offset. Note that the north side of the fault zone is consistently downthrown; this is not the case in the Pennsylvanian strata. Several northwest-trending faults also are indicated by the subsurface data. The postulated northeast-trending fault in T. 7 S., R. 1 E. does not correspond to any known structure in the Pennsylvanian strata.

the possibility that several stages of movement, perhaps involving reversals of the direction of uplift, deserves to be considered. Schwalb (1979; and in press) argues convincingly that such reversals have occurred along the Rough Creek Fault System in western Kentucky. Evidence from deep drilling shows that middle Cambrian through Devonian strata are deeper and thicker on the south side of the fault system than on the north side. Schwalb contends that movements along the faults began in the early Cambrian with major displacement down to the south, allowing greater sedimentation there. The displacement may have reversed during the Mississippian; Pennsylvanian strata are thicker north of the Rough Creek System than south of it. In present exposures Pennsylvanian rocks are generally downthrown north of the zone. A channel in the Maquoketa Shale (Ordovician) and another in the Bethel Sandstone (Mississippian) cross the fault zone obliquely without

showing appreciable horizontal offset (Howard R. Schwalb, personal communication, 1979) within the limits of data control, about 0.6 miles (1 km). In outcrop, the fault zone exhibits slickensides and patterns of minor faults and folds, which indicate vertical dip-slip movement with little or no component of strike-slip (Krause, Nelson, and Schwalb, 1979).

Nevertheless, we have no indications for either a physical or a genetic connection between the Cottage Grove and Rough Creek-Shawneetown Fault Systems. The styles of deformation in the two systems differ considerably. The Rough Creek Fault System comprises a braided system of faults forming a zone several miles wide in most places. Subsidiary faults north and south of the zone strike dominantly northeast to east-northeast, opposite to the strike of subsidiary faults in the Cottage Grove Fault System (Schwalb and Potter, 1978). It is difficult to visualize the

Rough Creek-Shawneetown Fault System as a right-lateral wrench zone, as Heyl (1972) proposed. The pattern of subsidiary faults suggests that, if anything, horizontal movements in the region were left lateral.

Reversed uplifts of crustal blocks could be said to account for "scissoring" and false drag on the master fault zone of the Cottage Grove Fault System, but it is difficult to believe that long-term, reversed movements would be confined to such a narrow zone as that of the master fault. Rather, we should expect a broad zone of subparallel faults, like that of the Rough Creek System, to be produced. Furthermore, the northwest-trending subsidiary faults would have to be the result of a separate stress field unrelated to that responsible for the master fault. All indications are that the master fault zone and subsidiary faults are directly related and were developed in the same stress field.

There is only one reasonable interpretation of the structural pattern of the Cottage Grove Fault System. The faults and related structures in the Pennsylvanian rocks are the direct surficial expression of right-lateral movements along an east-west trending fracture in the crystalline basement. Vertical movements within the CGFS are secondary and incidental to the primary wrenching action.

Amount of offset

Now that we have stated our case for right-lateral movement in the Cottage Grove Fault System, it is reasonable to inquire into the magnitude of this movement. Measurement of displacement along strike-slip faults can be difficult, particularly so in the case of small displacements in gently dipping rocks. Direct determination of strike slip requires locating a feature, such as a lithologic body or a structural axis, that clearly preexisted the fault and has been offset by it.

Searching for offsets of the subsidiary faults and igneous dikes will not do. These structures are an integral part of the Cottage Grove Fault System and, as such, may have developed contemporaneously with the master fault zone. Some, or even most, of the subsidiary faults and dikes may predate slippage in the master fault zone, but we have no way of knowing which ones. If complete exposure of the intersection of dikes or faults with the master fault zone were available, determinations of offsets might be possible. Unfortunately, no such exposures are available because mining companies prefer to avoid operating in such heavily faulted areas.

Much better places to look for lateral offsets are along the Galatia and Walshville channels. The Galatia channel (Hopkins, Nance, and Treworgy, 1979) and the Walshville channel (Johnson, 1972) are the courses of major streams that existed during accumulation of the Harrisburg (No. 5) and Herrin (No. 6) Coals. Along the courses of the channels the coal seams are replaced by fluvial deposits of shale, siltstone, and sandstone. Both channels follow sinuous

courses that can be traced for considerable distances across Illinois (Smith and Stall, 1975). The Galatia channel crosses the Cottage Grove Fault System in central Saline County, and the Walshville channel intersects the fault zone in eastern Jackson County (plate 1).

Examination of plate 1 indicates that no major offsets of either channel have taken place. As for smaller displacements of several hundred to a few thousand feet, much less can be said. The limits of the mined-out areas do not accurately reveal the boundaries of the channels. Neither channel has definite borders; rather they are flanked by broad zones along which the coal is split and locally cut out by minor subsidiary channels. Mining companies differ widely in how they treat split coal. Some companies mine ahead aggressively as long as one bench of the seam retains a minable thickness; others tend to quit when splits exceed a foot or so in thickness. Therefore, small lateral offsets of the channel by the fault might be masked by the large uncertainty as to the position of the edges of the channel.

A strong suggestion of right-lateral offset is seen at the east side of the Galatia channel along the northern, major branch of the master fault zone. Peabody Coal Co. Mine No. 43, immediately south of the fault zone, mined approximately a mile (1.6 km) farther west than did Sahara Mine No. 1 immediately north of the fault. The irregular western boundaries of both mines represent areas where the operators were probing the split coal along the Galatia channel. Because the master fault zone here is continuous, trends nearly due east, and shows large vertical separation, this is a prime place to look for a large lateral displacement. We are tempted to state that a mile of right-lateral offset is demonstrated, but we must be cautious in light of the uncertainties mentioned above.

No corresponding right-lateral offset is seen on the west side of the Galatia channel. This is expected because the master fault is known to be discontinuous here. Wrenching stresses apparently were relieved through oblique slippage along northwest-trending faults (see details of Study Area 1, p. 33). Additional relief may have been achieved through folding or through slippage along the southern branch of the master fault.

The southern branch does not visibly offset the border of the Galatia channel. Perhaps strike-slip movements were of too small a magnitude to be noticeable at the scale of plate 1. Another distinct possibility is that the southern branch is not a right-lateral fault but is some form of secondary structure in the Cottage Grove Fault System.

Displacement of the Walshville channel by the master fault zone cannot be demonstrated. The position of the channel is known quite well north of the fault, but south of the fault the channel is poorly delineated. The best that can be said is that offset, if present, is less than a mile (1.6 km).

Other considerations limit the amount of possible lateral offset in Pennsylvanian strata by the Cottage Grove

Fault System. The master fault zone is discontinuous, so in some segments of the fault system no pure strike-slip motion has occurred. Wrenching stresses in such areas may have been accommodated through oblique slippage on subsidiary faults, rotation of blocks, folding, or interlaminar slip, yet the total amount of such observed deformation cannot account for more than a few hundred feet of slip. In areas where the master fault zone is well developed, larger movements likely occurred. We can accept lateral offset of an order of magnitude greater than the maximum vertical separation, i.e. 2,000 feet (600 m) in places. Much larger movements seem unlikely, however, and would have produced unmistakable effects had they occurred.

In summary, continuity of the Galatia and Walshville channels places the upper limit of strike-slip offset of Pennsylvanian rocks along the Cottage Grove Fault System at about 1 mile (1.6 km). The most reasonable estimate of lateral displacement is that it probably varies from a few hundred to a few thousand feet.

Estimates of strike-slip displacement in deeper strata must be highly speculative. One would expect the offset in the basement to be greater than that observable near the surface. Nonetheless, Heyl's (1972) postulation of 50 miles (80 km) of right-lateral offset along the 38th Parallel Lineament appears much too high. It is hardly credible that this much displacement in the basement should produce only a few thousand feet (at the most) of strike slip at the surface. Furthermore, as we have shown, strong doubt exists as to whether the Cottage Grove Fault System joins the Shawneetown-Rough Creek Fault System on the east or continues beyond the Bremen Anticline in Randolph County on the west. Little evidence exists to support significant strike-slip movement in the Shawneetown-Rough Creek System. The Cottage Grove Fault System is the only member of the 38th Parallel Lineament in the midcontinent area that shows clear indication in the field of right-lateral strike-slip movement.

Age of faulting

Movements in the Cottage Grove Fault System clearly occurred after middle Pennsylvanian time and before Pleistocene time. None of the faults are known to offset Pleistocene sediments. Further stratigraphic dating of the time of faulting is not possible because no rocks of intermediate age are present along the fault system.

The igneous rocks in Saline and eastern Williamson Counties should be susceptible to radioactive age determinations. We believe (p. 16) that the dikes were intruded during the time of faulting. Accordingly, dating the dikes should allow dating the faults. To our knowledge, no radioactive dating has been accomplished yet on igneous rocks from the Cottage Grove Fault System. Zartman et al. (1967) applied potassium-argon and rubidium-strontium methods of dating to igneous rocks from the fluorspar mining area of southeastern Illinois and the adjacent portion of Kentucky.

These rocks, which are compositionally similar to rocks in the dikes of Saline County, yield an average age of 267 ± 20 million years, or early Permian (Zartman et al., 1967). The Permian was a time of intense structural deformation in the Appalachian and Ouachita regions; thus, it is not unreasonable to assume that the CGFS was active during this time.

Possibly the Cottage Grove Fault System also was active in times preceding Pennsylvanian sedimentation, but no hard evidence exists to support this view. No Paleozoic strata show changes in thickness or facies that can be related to movement on the CGFS. Failure along faults in the coal-bearing sequence is dominantly brittle, and no suggestions can be found of movements contemporaneous with deposition. Ductile deformation in the CGFS reflects gradual accumulation of strain or drag along faults and does not indicate that the sediments were incompletely lithified at the time of faulting.

To summarize, the faulting can only definitely be dated as post-middle Pennsylvanian and pre-Pleistocene. Radiogenic ages of igneous dikes similar to those in the Cottage Grove Fault System suggest that faulting occurred in early Permian time and was related to the Appalachian and Ouachita disturbances.

NORTH-SOUTH FAULTS NEAR COTTAGE GROVE FAULT SYSTEM

Within and adjacent to the Cottage Grove Fault System are several sets or systems of faults that trend generally north-south. Three of these sets of faults have been named, two of the names being new to this study. None of these faults are believed to be genetically related to the CGFS. However, the north-south faults merit discussion because of their proximity to and interaction with the CGFS.

Small thrust faults in Saline and Williamson Counties

A number of small north-trending faults or fracture zones have been mapped in coal mines of southwestern Saline and southeastern Williamson Counties (plate 1). These faults lie within and just south of the belt of subsidiary faults of the Cottage Grove Fault System. Wherever details of the north-trending faults are available, they are found to be low-angle reverse faults having maximum net slip of less than 10 feet (3 m) and vertical separations typically measured in inches. Although their offset is slight, these faults have severely disrupted mining by weakening the roof strata and admitting water into the workings. The traces of several of these faults have been inferred from zones of unmined coal visible on maps of abandoned mines.

One such fracture zone was encountered in Mine No. 21 of Sahara Coal Company in the NW $\frac{1}{4}$ NW $\frac{1}{4}$ Sec. 21, T. 9 S., R. 5 E., Saline County. In the one entry where it

was well exposed, the structure comprised a series of low-to-moderate-angle thrust faults and sharp flexures (fig. 22). Locally the coal and shale were pulverized along zones of movement. The amount of vertical offset is slight, and the coal shows no relative uplift on either side of the zone. Maps of Sahara No. 21 and adjacent mines indicate that the zone is continuous for roughly 1.5 miles (2.4 km). The fractures produce problems of water influx and unstable roof and have been largely left unmined inside solid pillars of coal.

A similar fault zone was encountered in the Harrisburg Coal Co. mine in Sec. 26, T. 9 S., R. 4 E., Williamson County. This system of fractures strikes slightly east of north (20°) and is continuous across the entire mine. The faults are low-angle thrust faults that locally follow bedding surfaces in the coal (fig. 23). A small amount of drag and compressional folding of the strata also is apparent. Again the faults cause severe difficulties in roof control and the company has tried to avoid mining into them.

A north-trending fault in abandoned Sahara No. 7 Mine is a reverse fault with about 2 feet (0.6 m) of throw, according to unsigned sketches in the field notes of the Illinois State Geological Survey. The plane of the fault dips about 45 degrees, and one of the sketches shows strong drag folding in the coal along the fault plane. The

appearance is very similar to that of the faults in figs. 22 and 23.

All these structures signify that the area was subjected to a slight amount of east-west horizontal compression without a significant component of either vertical uplift or strike-slip movement. These stresses are not consistent with those assumed to have been operative in the Cottage Grove Fault System. Therefore, the north-trending faults probably developed at a different time than the CGFS. Which system is older and how the north-trending faults relate to the regional structural picture cannot be answered on the basis of available evidence.

The Rend Lake Fault System

The Rend Lake Fault System is a set of an echelon, dominantly high-angle normal faults that extend northward from the CGFS for about 25 miles (40 km) in Franklin and Jefferson Counties (fig. 2 and plate 1). The structure and origin of these faults have been discussed in detail by Keys (1978) and Keys and Nelson (1980). They attributed the origin of the faults to east-west horizontal extension, as a result of north-south trending differential uplift and subsidence.

Where the Rend Lake Fault System approaches the

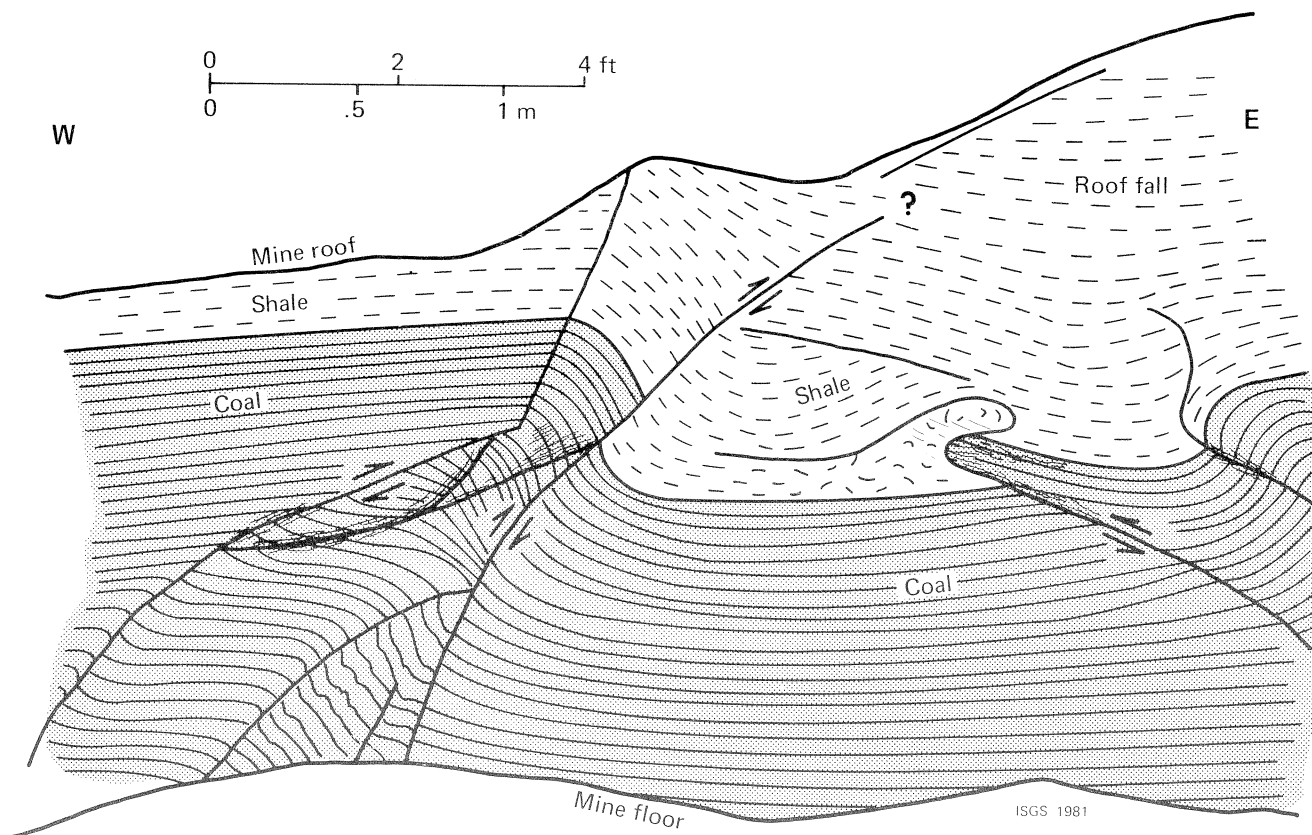

Figure 22. North-trending thrust faults in Harrisburg (No. 5) Coal and Dykersburg Shale at Mine No. 21, Sahara Coal Company. Curving low-angle faults and sharp flexures express horizontal east-west compression. Little relative displacement has taken place across the fault zone. Although offsets along these faults are small, miners avoid them because they are associated with water and unstable roof conditions.

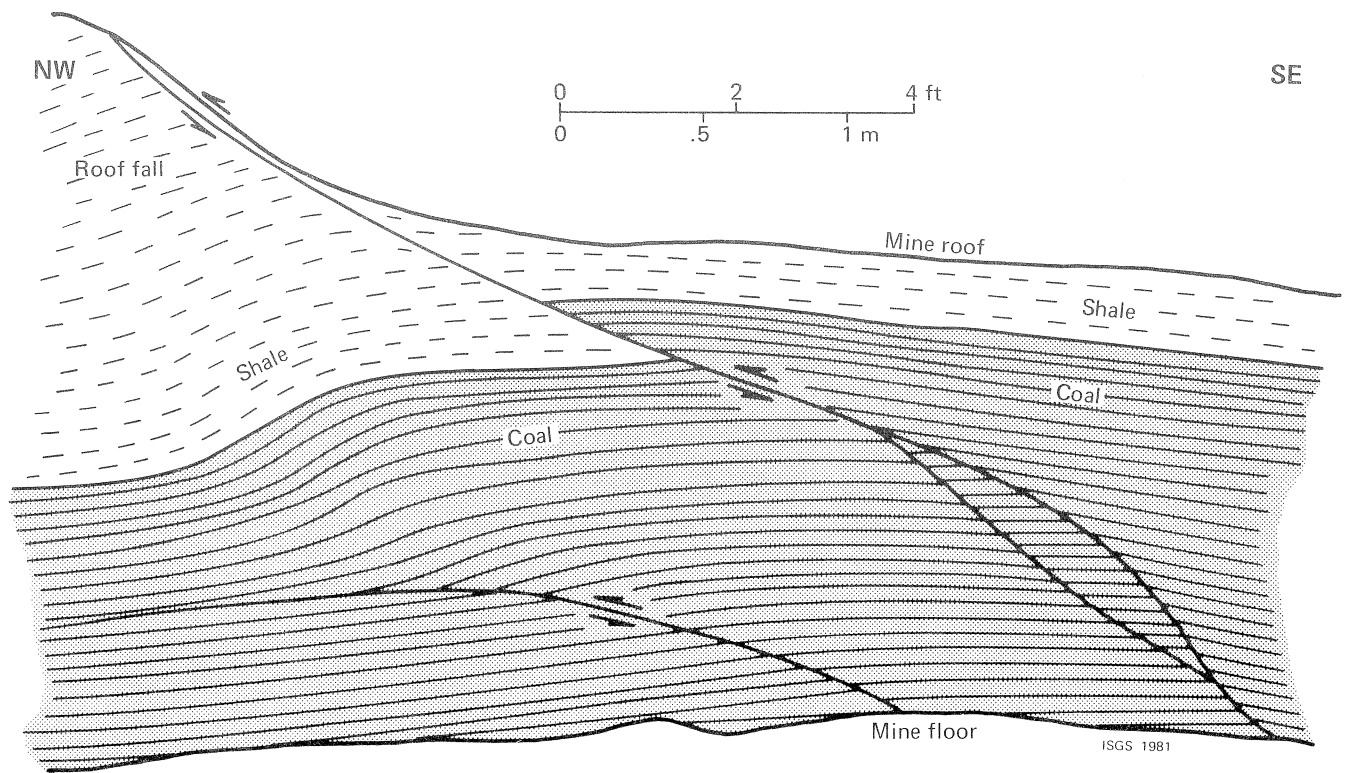

Figure 23. North-trending low-angle thrust faults in mine of Harrisburg Coal Company, southeastern Williamson County. Faults locally follow bedding planes in coal. Folding of strata is consistent with horizontal compressive stresses. The low-angle fault planes are hazardous planes of separation in the roof.

Cottage Grove Fault System, faults of the former become offset to the east and diminish in displacement. A fault in Old Ben Mine No. 15 strikes north-south in its northern extent and curves southward toward a south-southeasterly heading. Thus, it has the character of a Rend Lake fault in its northern portion and a Cottage Grove fault in its southern extent. On the basis of these observations, Keys (1978) and Keys and Nelson (1980) concluded that the Rend Lake Fault System is contemporaneous with or younger than the CGFS, the latter acting as a stress-relief field for the former in its southerly extent.

The White Ash Fault Zone

The name White Ash Fault Zone is applied in this report to a north-trending set of faults immediately south of the Cottage Grove Fault System in central Williamson County (plate 1). The White Ash Fault Zone is named for the village of White Ash, near which it passes. The White Ash faults are known to extend from the outcrop of the Springfield (No. 5) Coal in the NE $\frac{1}{4}$, Sec. 10, T. 9 S., R. 2 E., to the center of Sec. 23, T. 8 S., R. 2 E. The overall strike of the zone is slightly east of north (15°), and the trend of individual faults varies from roughly slightly east of south (170°) to northeast (55°).

The White Ash Fault Zone is known from exposures in surface and underground coal mines and has been inferred

from drill-hole data. Faults with the east side downthrown and faults with the west side downthrown are about equally represented. The throw of individual faults is as great as 58 feet (18 m).

Available evidence indicates that most of the White Ash faults are high-angle normal faults. Netzeband (ISGS, unpublished field notes) observed and sketched two high-angle normal faults in Mine No. 26, Peabody Coal Company. The faults strike approximately 20 degrees and are downthrown to the east, with throws of 1 foot (0.3 m) and 2 feet (0.6 m). The sketch shows the coal and shale to be cleanly sheared, with no appreciable drag and only a thin layer of gouge along the fault plane.

We recently observed several faults of the White Ash Fault Zone on the highwall of the E. & B. Coal Co. No. 1 Mine, a surface mine in the Springfield (No. 5) Coal in the NE $\frac{1}{4}$ of Sec. 10, T. 9 S., R. 2 E. The westernmost fault is a high-angle normal fault striking 10 degrees and having the east side downthrown 14 feet (4.3 m). The strata showed no drag; striations on the fault surface indicated pure dip-slip movement. East of the 14-foot fault was a similar fault with the west side downthrown 6 feet (1.8 m), forming an asymmetrical graben. No ductile deformation was visible; the strata failed purely in a brittle manner by shearing.

Several hundred feet east of these faults two smaller displacements were observed in strata above the Springfield Coal. One of these is a reverse fault striking northeast (55°),

dipping northwest (30°), and having a maximum of 1.4 feet (0.4 m) of throw. The displacement of this fault diminishes both upwards and downwards, so it appears to be a small local feature. The other fault is a normal fault with 0.1 feet (0.03 m) of throw. Like the faults to the west, these faults display no drag. The normal fault is possibly a compactional structure, but the reverse fault is probably tectonic in origin. Just east of the two small faults the coal company reported mining into a major fault with the east side downthrown 40 feet (12 m). The large fault was not accessible for study because the land had been reclaimed.

The Springfield (No. 5) Coal in the strip mine displays prominent cleat. The face cleat trends north-northeast (20° to 30°) and the butt cleat east-southeast (113° to 124°). These directions are nearly parallel and perpendicular, respectively, with the strike of the faults observed in the pit.

The structural pattern of the White Ash Fault Zone is virtually the same as that of the Rend Lake Fault System, and the White Ash Fault Zone is directly in line with a southward projection of the Rend Lake Fault System. This suggests that both systems formed under the same set of extensional stresses and would have been continuous if the Cottage Grove Fault System had been absent. Additional support is thus lent to Key's (1978) statement that the Rend Lake Fault System developed during or later than faulting in the CGFS. Within the CGFS, the east-west extensional forces responsible for Rend Lake and White Ash faults probably were relieved by slippage along north-west-trending subsidiary faults. Therefore, no north-trending normal faults developed within the CGFS and the White Ash Fault Zone does not connect directly with the Rend Lake Fault System.

The Dowell Fault Zone

The Dowell Fault Zone is a series of high-angle normal faults bearing slightly east of north (15°) in northeastern Jackson and southeastern Perry Counties (plate 1). The faults apparently terminate southward against the master fault zone of the Cottage Grove Fault System, and they have been traced as far north as the Forester Coal and Coke Co. mine, in Sec. 10, T. 6 S., R. 1 W. The Dowell Fault Zone is named in this report for the village of Dowell, which lies near the southern terminus of the zone of faults. The fault zone was first described by Fisher (1925).

Exposures in the Kathleen Mine show that the Dowell Fault zone forms a zone of variable width composed of parallel, discontinuous high-angle normal faults. Most of the faults have the west side downthrown, but on several large faults the east block is down. Commonly the largest faults form a graben. The maximum observed throws are about 40 feet (12 m). The apparent northward diminution of the faults may reflect inconsistent mapping procedures of the coal companies rather than a true structural change; available mine maps are poor in quality and show little detail. Between the Forester Coal and Coke Co. and Du

Quoin Coal Company mines, the largest fault has approximately 35 feet (11 m) of vertical offset.

Although the Dowell Fault Zone is composed dominantly of high-angle normal faults, other types of movement have taken place within the zone. Fisher (1925) reported finding horizontal slickensides along a number of the faults in the Kathleen Mine. He also sketched in the same mine a high-angle normal fault that was offset along a horizontal bedding-plane fault in the coal (fig. 24). The normal fault, which had 7 feet (2.1 m) of throw, was offset 5.75 feet (1.75 m) in a direction perpendicular to its strike. The horizontal fault followed the "Blue Band" in the Herrin (No. 6) Coal east of the normal fault, and followed the top of the coal west of the normal fault. Both of these horizons represent natural planes of weakness in the strata.

We have observed precisely the same type of horizontal faults displacing earlier high-angle faults at several mines in Williamson County along the Cottage Grove Fault System. (Several examples are illustrated later in figures 30, 45, 46, 53, 54, and 55.) Slippage parallel to bedding appears to be characteristic of the Cottage Grove Fault System close to the master fault. The area in the Kathleen Mine where Fisher (1925) observed the horizontal fault and the horizontal slickensides is roughly 1 mile (1.6 km) north of the master fault. Accordingly, we can attribute these horizontal movements to slippage in the Cottage Grove Fault System during or after formation of the Dowell Fault Zone.

The Dowell Fault Zone follows the flank of the Du Quoin Monocline, and may be an antithetic or tension-

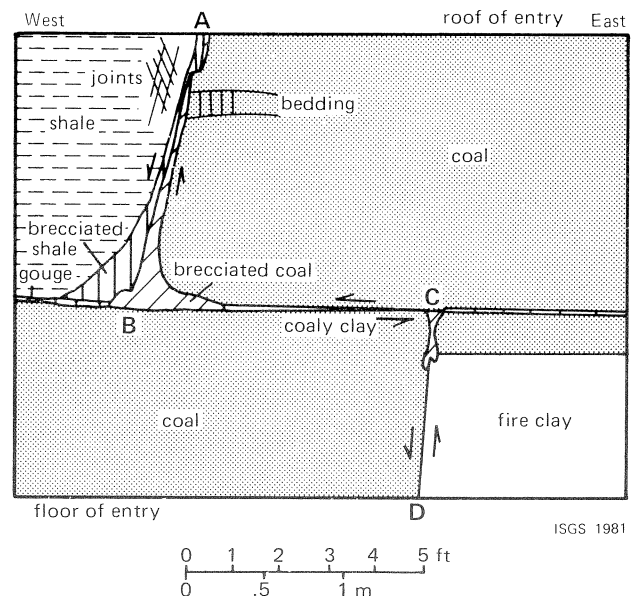

Figure 24. High-angle normal fault (A-B and C-D) offset by a horizontal fault (B-C) in the Herrin (No. 6) Coal at the Kathleen Mine in Jackson County. The normal fault strikes north-south and is part of the Dowell Fault Zone. The horizontal fault may be part of the Cottage Grove Fault System. Compare with figures 30, 53, 54, and 55. (From Fisher, 1925.)

release structure produced by the folding. This view is supported by the fact that normal faults, dominantly with the west side downthrown, have been found farther north along the flank of the monocline. The large faults in the mines at Centralia and other faults inferred from drilling or observed in mines are discussed in Keys and Nelson (1980). A zone of faulting may be continuous along the Du Quoin Monocline, but most of the faults are too small to be detected on the basis of the widely-spaced drill-hole data available.

Evidence shows that the Du Quoin Monocline was in existence prior to the Cottage Grove Fault System, which clearly is post-middle Pennsylvanian. Abrupt thickening of lower Pennsylvanian units on the east side of the monocline indicates that the monocline was present during that time, but the thickness of Mississippian formations is not affected (Siever, 1951; Brownfield, 1954). Howard Schwalb (personal communication) has determined that Croixan (upper Cambrian) formations 300 to 450 feet (90 to 135 m) thick west of the monocline increase abruptly to 800 to 1,500 feet (240 to 460 m) east of the fold. Middle Devonian limestones that are well developed east of the monocline are absent west of it. On this basis Schwalb concludes that the Du Quoin Monocline was developing intermittently through most of Paleozoic time. Post-middle Pennsylvanian movement of the monocline is proven by warping of the coal-bearing strata. The Dowell Fault Zone obviously is post-middle Pennsylvanian.

The Du Quoin Monocline, as mapped in the Herrin Coal, continues south of the master fault and shows no apparent strike-slip offset. The monocline dies out about a mile south of the master fault. Available evidence does not permit us to say whether faulting preceded or post-dated the final movements of the Du Quoin Monocline.

DETAILED STRUCTURE OF SELECTED AREAS IN UNDERGROUND COAL MINES

Seven areas selected for detailed mapping and structural analysis include all four underground coal mines currently active within the Cottage Grove Fault System (plate 1). The seven areas contain a wide variety of structural features, including segments of the master fault zone, many types of subsidiary faults, and portions of major subsidiary anticlines. Many structures cannot be shown adequately at the scale of plate 1, but are highly significant in the interpretation of the regional structural history. The examples presented here will illustrate some of the problems and hazards that faults pose to coal mining and will suggest ways to alleviate these difficulties.

Study Area 1

Study Area 1 (fig. 25) is located in the northeastern workings of Mine No. 20, Sahara Coal Company, in Section 2,

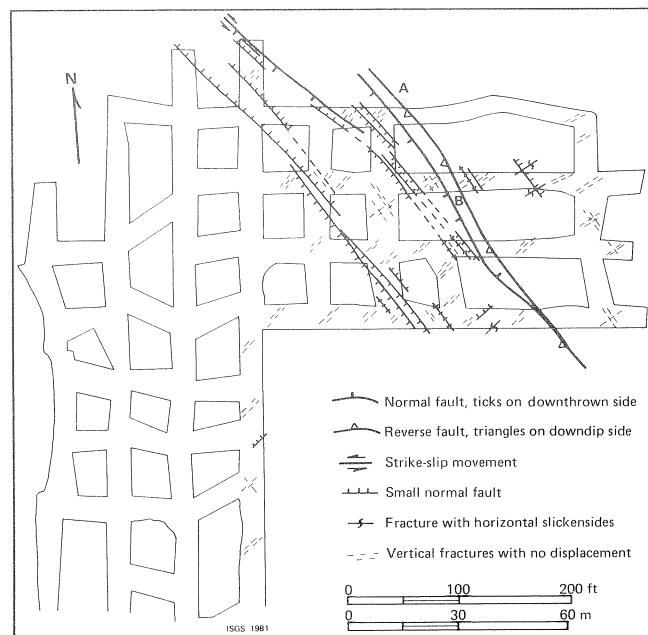

Figure 25. Faults in Study Area 1, Sahara Coal Co. Mine No. 20. For regional location see figure 6 and plate 1. Letters A and B refer to figures 26A and B.

Brushy Township (T. 9 S., R. 5 E.) Saline County. Sahara No. 20 is operating in the Springfield (No. 5) Coal. The general structural setting of Study Area 1 has been described on p. 10. The study area lies across the projected line of the master fault zone in a region where the zone is discontinuous. Two sets of northwest-trending subsidiary faults are present in Study Area 1.

The southwestern set of northwest-trending faults in Study Area 1 extends about 2,800 feet (850 m) through Sahara No. 20 and lies directly in line with a fault that extends nearly 3 miles (4.8 km) through the abandoned workings of Peabody Coal Company Mine No. 47 to the northwest (fig. 6). Most of the faults in the set are high-angle normal faults, but high-angle reverse faults also are present. The largest observed throw in Sahara No. 20 is 5.5 feet (1.7 m).

The northeastern set of northwest-trending faults crosses the northernmost portion of Study Area 1 and, like the southwestern set, lines up with a fault in Peabody Mine No. 47 (fig. 6). In Sahara No. 20, the fault zone is about 100 feet (30 m) wide and its structure indicates oblique-slip movement. As shown in figure 25, the zone comprises multiple northwest-trending faults and minor southwest-trending faults and fractures.

The most intensive deformation occurred in a zone 1 to 10 feet (0.3 to 3 m) wide near the northeastern edge of the set of faults. Within this narrow zone are numerous faults that are dominantly inclined toward the southwest (fig. 26A and B). The coal lies at very nearly the same elevation on opposite sides of the fault zone. Within the zone, however, individual slices of coal have been upthrown

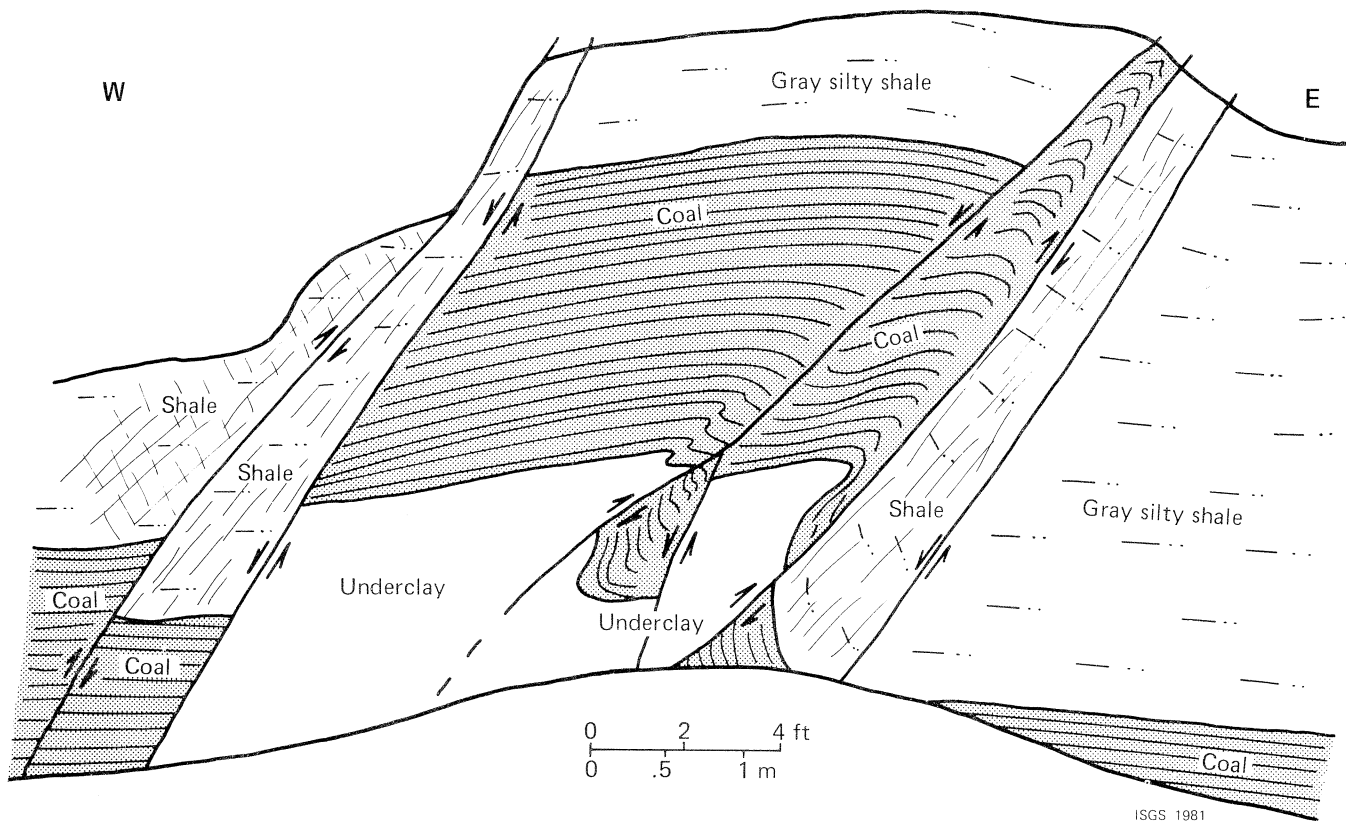

Figure 26A. North rib at Location A in figure 25. A complex fracture zone comprising a series of normal and reverse faults striking 140 degrees and dipping to the southwest. Strata are upthrown and sharply folded within the fault zone, but the coal lies at nearly the same elevation on opposite sides of the zone.

as much as 10 feet (3 m) (figs. 26 A and B). The slices display intense folding, brecciation, and local pulverization of rock. The direction of folding is commonly inconsistent with the apparent direction of throw on faults. Slickensides within the fault zone indicate dip-slip, oblique-slip, and strike-slip movements.

The structure of the fault zone is strongly indicative of an initial event of high-angle normal faulting in response to horizontal extension from northeast to southwest. With continued wrenching movements in the rocks below the coal, a second stage of reverse and probably strike-slip movement occurred along the same faults. Thereby the coal was returned to nearly its original position on opposite sides of the fault zone, but individual narrow slices of coal were isolated above and below the main seam within the fault zone.

Study Area 2

Study Area 2 contains a portion of a subsidiary fault in the Springfield (No. 5) Coal at Mine No. 21, Sahara Coal Company, in Sec. 8 and 17, T. 9 S., R. 5 E., Saline County. The area of study lies in the north-central part of the mine, south of the master fault. A series of faults striking north-northwest was encountered at the face of a set of entries being driven northeastward. The largest fault had 10 to

11 feet (3.0 to 3.3 m) of throw on the northwestern entry and diminished to about half that amount in the adjacent entry, 80 feet (24 m) away.

Sahara's engineers knew that the faults died out to the south, because a previously mined area on line with the faults southward had contained no faults. Accordingly, Sahara halted development at the faulted face and started a new set of entries about 1,000 feet (300 m) farther south, which would cross the fault zone at a right angle. The plan was successful; no large displacements and only minimal problems with unstable roof were encountered.

The structural pattern of the fault zone in the new entries is shown in figure 27. The zone of faults is about 400 feet (120 m) wide, and most of the fractures strike nearly north-south. The largest faults have about 2 feet (0.6 m) of throw, but the amount of displacement varies rapidly along strike. Most of the faults are high-angle, normal, dip-slip faults, but a few small reverse faults are present, and several fracture surfaces display horizontal or obliquely dipping slickensides. In some places vertical faults have been offset along small bedding-plane faults. A few faults appear as vertical or steeply dipping zones of crushed coal and shale; there is no clear-cut fault plane, and direction of dip-slip movement is inconsistent along strike. These features indicate that, although horizontal extensional stresses are predominant, a component of strike-slip shearing

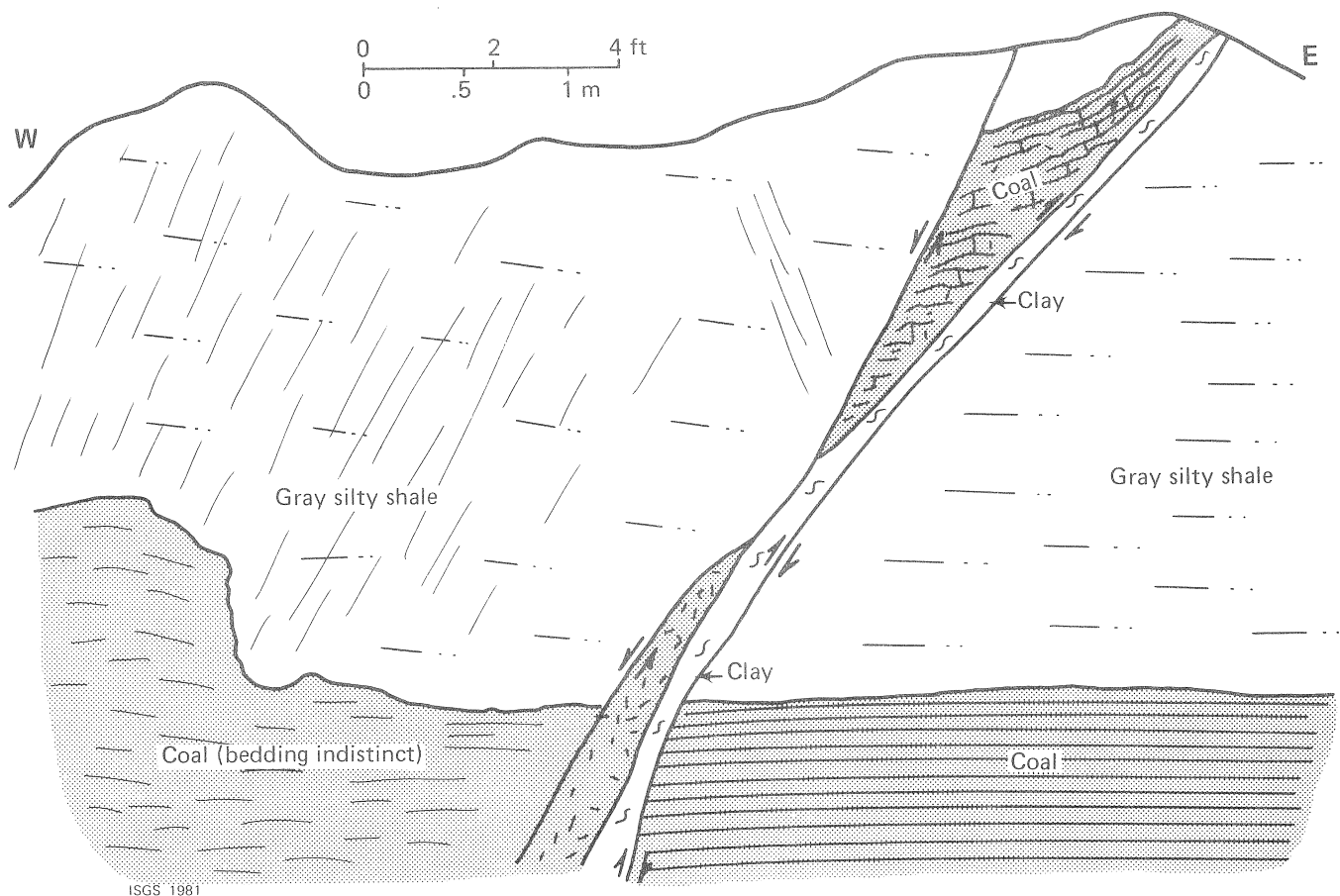

Figure 26B. South rib at Location B, figure 25. Here the fault zone is much narrower than at Location A but the coal is even more strongly upthrown within it. Along the east side of the fault a narrow sliver of gray shale from the roof is downdropped into the coal. No vertical offset is visible across the zone; the coal is at the same level on opposite sides of the zone. West of the main faults the coal and shale are intensively fractured and somewhat folded.

also was active. They also demonstrate that faulting occurred as a series of incremental movements rather than as a single action.

Study Area 3

Study Area 3 (figs. 28 and 29) is located near the center of Section 30, Corinth Township (T. 8 S., R. 4 E.). The study area comprises a portion of a set of main entries in the eastern part of Orient No. 4 Mine of Freeman United Coal Mining Company, where the Herrin (No. 6) Coal is mined. The study area lies along the southeastern flank of the Pittsburg Anticline, where the coal locally is inclined as much as 24 degrees. Most of the faults in the study area strike east-northeast (75° to 80°) and follow the elevation contours of the coal. Individual faults may curve or branch along strike (fig. 28), but the overall trend is consistent.

The east-northeast striking faults are normal faults, and on most of them the northern, up-dip block is downthrown. The northernmost faults have gently inclined planes (about 35°); southward the dips steadily increase to a maximum of about 75 degrees on faults at the foot of

the anticline (fig. 29). The maximum throw observed within the area mapped is 15 feet (4.5 m). Throws of individual faults vary considerably along strike. The largest faults are concentrated along the most steeply dipping part of the anticlinal flank.

One of the east-northeast trending faults ("A" in figures 28 and 29) differs from the rest in that it undergoes a reversal in direction of throw. Along the eastern extent of Fault "A" the northern block is downthrown about 6 feet (1.8 m). Westward the throw diminishes to zero and the fault becomes vertical along the line of profile illustrated in figure 29. In the westernmost entry the fault is vertical and the southern block is downthrown 8 feet (2.4 m). Associated with the western segment of Fault "A" are open vertical fractures, lined with calcite where they penetrate the Brereton Limestone. Although "scissoring" of a fault suggests strike-slip movement, Fault "A" bears no other indications of lateral movement; we assume that it is a dip-slip fault. All of the other east-northeast trending faults likewise appear to have experienced only dip-slip movement.

Slippage parallel to bedding in the shale immediately

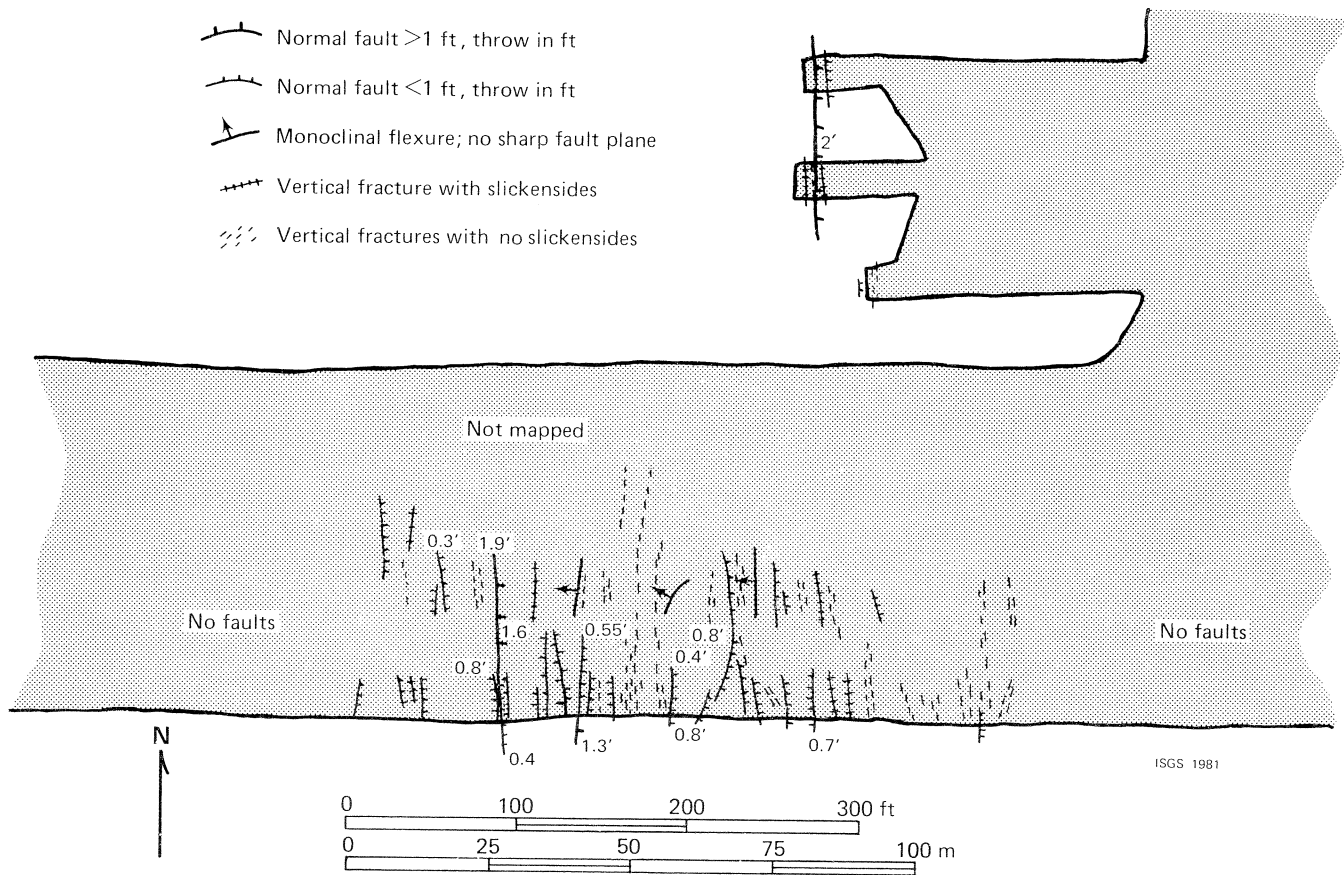

Figure 27. Faults in Study Area 2, Sahara Coal Co. Mine No. 21. Faults are trending nearly north-south and their throw decreases southward. About 1,000 feet (305 m) north of here, faults with up to 10 feet (3.1 m) displacement were encountered.

above the coal has occurred just north of Fault "A," as indicated by the small arrow at "A" in figure 28. Slippage has locally involved the entire thickness of the Energy Shale, a weak, poorly laminated medium-gray mudstone. In the zone of slippage the Energy Shale is crumpled and contorted, although the overlying black, fissile Anna Shale is gently folded and offset by small faults that do not penetrate (through) the Energy Shale. The coal is not visibly deformed. In an adjacent entry, slippage along a single bedding plane in the Energy Shale has truncated and offset normal faults (fig. 30). The area where slippage is visible is small, less than 100 feet (30 m) in diameter. Although no direct indications of the direction and amount of horizontal slippage could be found, the form of small folds in the Energy Shale suggests that the overlying strata slid down dip (to the south) relative to the coal. However, offsetting of small normal faults in figure 30 suggests opposite, up-dip movement.

Strike-slip movement has been recognized on faults "B" and "C" in figure 28 and also along two faults north of the map area. Although the faults are small, features indicative of horizontal movement are very prominent.

The trend of Fault "B" is north-south, nearly perpendicular with the anticlinal flank and the normal faults.

The fault was traced for about 350 feet (107 m), and the inclination of the fault plane varies from about 40 degrees to vertical. The amount of vertical offset is small, less than 1 foot (0.3 m), and the direction of throw is not consistent. Horizontal slickensides and grooving are prominent along the fault in several places.

The strike-slip fault intersects several large normal faults, but no offset of the latter by the former was detected. Several small vertical fractures end against the strike-slip fault, yet we could not identify the same fracture on opposite sides of the fault to demonstrate lateral displacement. In one location, drag and small en echelon fractures oblique to the main fault seem to indicate right-lateral movement. The amount of strike-slip movement is probably small, not more than a few feet.

West of Fault "B" (and off the mapping area of figure 28) is another north-south trending strike-slip fault that has been mapped more than 500 feet (152 m) across a set of main entries. Again strike-slip movement is demonstrated by horizontal grooving and slickensides (fig. 31) and by reversals in the direction of apparent vertical displacement. In most places the fault plane undulates in strike and dip, and the fault zone resembles a small, steep-sided graben (fig. 32). The development of such grabens

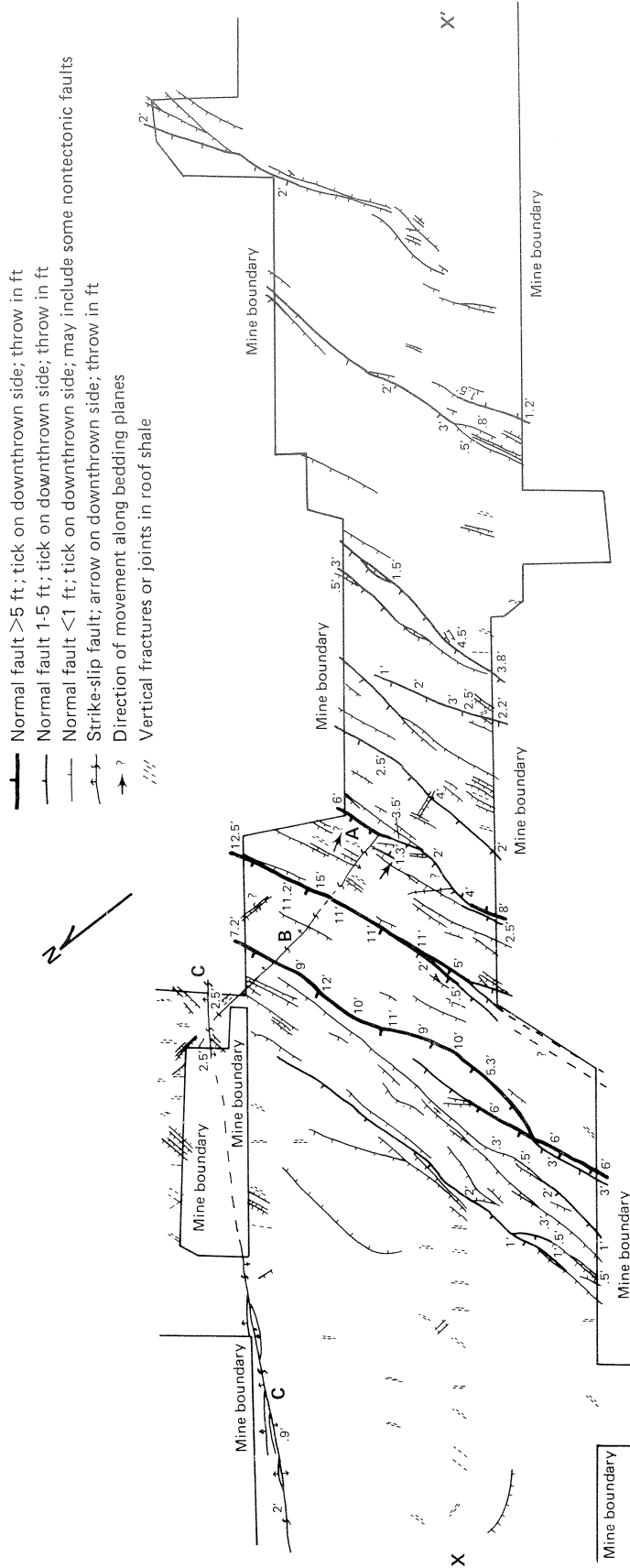

Figure 28. Faults in Study Area 3, Southeast Mains, Freeman United Coal Mining Company's Orient No. 4 Mine. X-X' is line of cross section in figure 29.

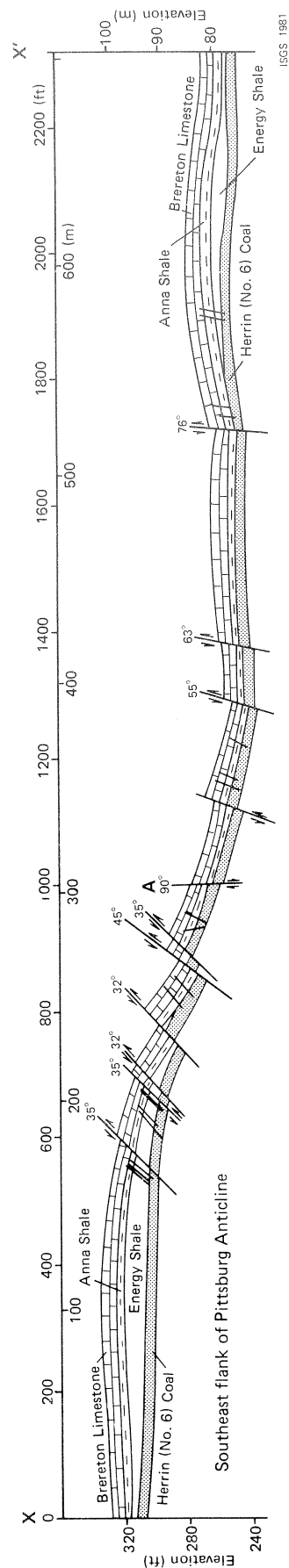

Figure 29. Cross section of Study Area 3. Profile shows the south flank of the Pittsburg Anticline and associated faulting (compare map, fig. 28). Large faults are confined to steep flank of anticline and nearly all are normal faults antithetic to the dip of the strata. Note how dip angle of faults increases down flank of fold toward the southeast.

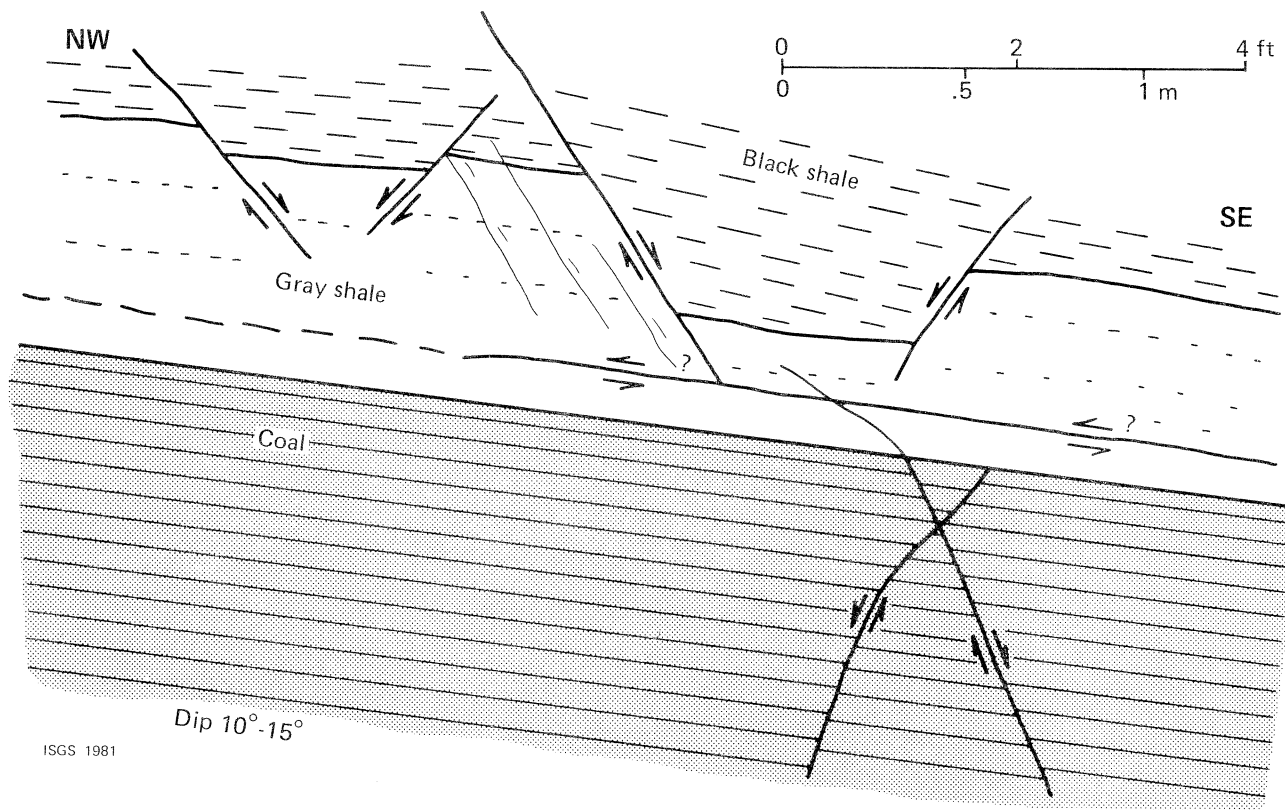

Figure 30. Slippage parallel to bedding at Location A in Study Area 3. Here the horizontal movement has taken place along a discrete shear plane in the Energy Shale. Normal faults are truncated and offset by the bedding-plane fault. The strata above the bedding-plane fault are believed to have moved updip to the northwest, but this could not be positively determined.

has been explained in figure 8. Toward the south the fault splits and shows horizontal slickensides with all branches. East of this fault is another similar strike-slip fault (not shown), not mapped or studied in detail.

The largest strike-slip fault (Fault "C," fig. 28) trends about 130 degrees and has been traced more than 800 feet (244 m) along strike. Features seen along this fault are similar to those of the north-south faults, but the vertical displacements are considerably larger and the zone of disturbance is wider, up to 10 feet (3 m). In most places the fault plane is nearly vertical, but it curves in dip direction. At one point the fault zone forms a narrow horst with the bedding in the central, up-thrown block, steeply tilted (fig. 33). The most likely explanation of this structure is that movement along the two downward-converging fault planes squeezed the central block upward.

The direction and amount of lateral movement on Fault "C" are not known. No vertical fractures were noticeably offset along Fault "C." On the contrary, several small fractures appear to cross Fault "C" without interruption. This finding does not negate strike-slip movement on Fault "C," because Fault "C" may be older than the fractures which cross it.

The very close geometric relationship of east-northeast trending normal faults with the Pittsburg Anticline in Study Area 2 indicates that faults and folds are genetically related. The faults dip opposite to the inclination of the flank of the

anticline. Such an arrangement implies that the faults formed as the result of localized tensional stresses on the flank of the anticline as it was rising. Further support for this theory is provided by the low inclination of faults high on the fold. Normal faults resulting from horizontal extension generally dip at 60 degrees or greater. On the flanks of a fold, however, the direction of maximum extension is not horizontal but is inclined to be roughly parallel with the dip of the strata. A fault formed on the flank of a fold thus dips more gently than one formed in horizontal strata (fig. 34). Additional lowering of the inclination of faults may have been accomplished by tilting of the blocks after the faults were formed.

Fault "A," which undergoes "scissoring," probably originated as a normal fault like the others, but along one portion the south side rather than the north side was downthrown. The near-vertical dip of the western part of Fault A is consistent with the mechanism proposed above for the origin of the other normal faults. The inclination of extensional forces and possible tilting of strata after faulting would tend to increase, rather than decrease, the dip of a south-facing fault (fig. 34).

No explanation is entirely satisfactory to account for the bedding-plane slippage north of Fault "A." The slippage may not be related to movements in the Cottage Grove Fault System and its relationship to other structures nearby is unclear. Bedding-plane slippage commonly occurs

in response to folding of layered rocks. However, such slip generally takes place in small increments along many bedding planes rather than as major displacements along a few surfaces. Furthermore, if slippage were due to folding, slippage should be evident all along the anticlinal flank rather than confined to a small area. Gravitational sliding of tilted beds is a possibility, but there are still unanswered questions. The foremost question is the state of lithification in the Energy Shale at the time of slippage. In the soft, deeply weathered gray shale, distinguishing brittle from ductile deformation is difficult. Gravitational sliding normally takes place in unlithified sediment, but conceivably

a fully lithified, yet poorly competent shale such as the Energy Shale also could slip parallel to bedding, particularly if water were present to lubricate the surfaces of slippage.

Faults "B" and "C," (fig. 28) and the fault in figure 31 definitely are strike-slip faults having only an incidental component of dip slip. They apparently are older than some normal faults in the vicinity, but are younger than others (some normal faults cross the strike-slip faults, but others are interrupted or offset). These small strike-slip faults probably are second-order or antithetic shears (fig. 17) resulting from wrenching movements along the master fault zone, northeast of the study area.

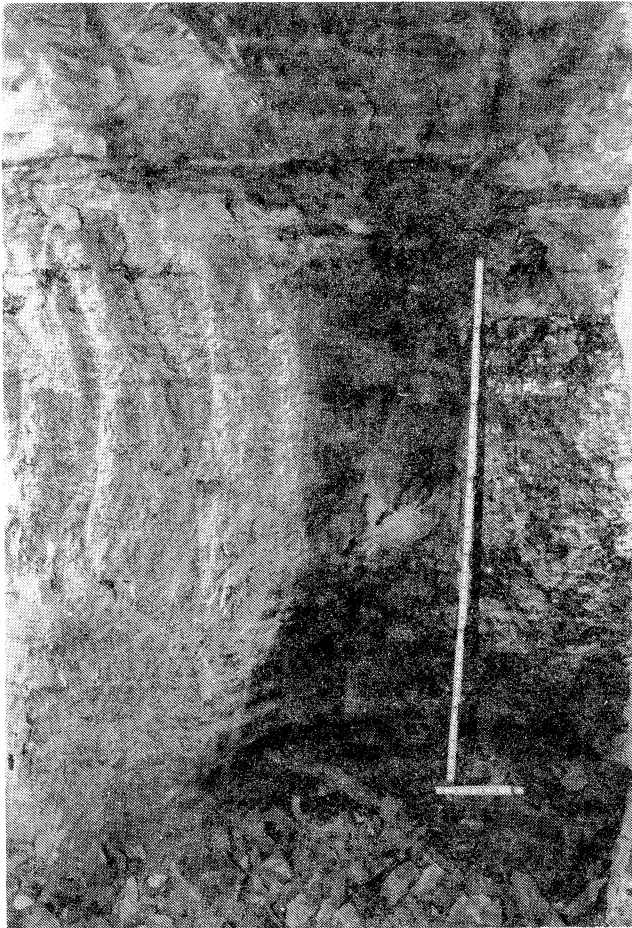

Figure 31. Surface of a fault illustrating horizontal striations along the fault in the coal.

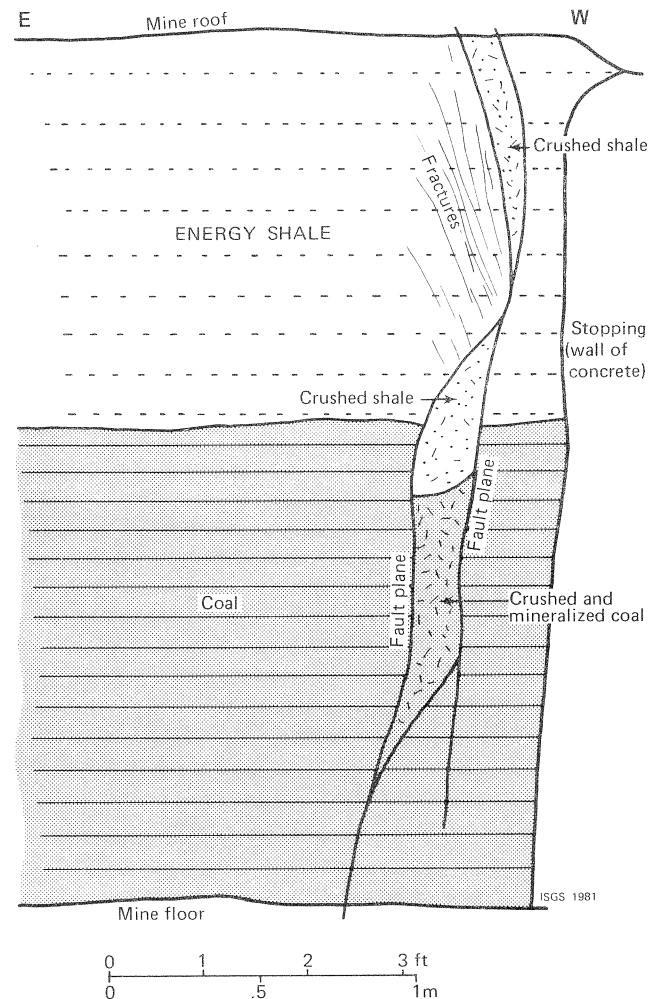

Figure 32. Cross-sectional view of the fault shown in figure 31. The graben form characteristic of many strike-slip faults is shown. The coal and shale between the two fault planes is thoroughly crushed and probably dropped into place during horizontal movement on the two fault planes. Both faults here display prominent horizontal slickensides and grooving, further evidence of strike-slip movement.

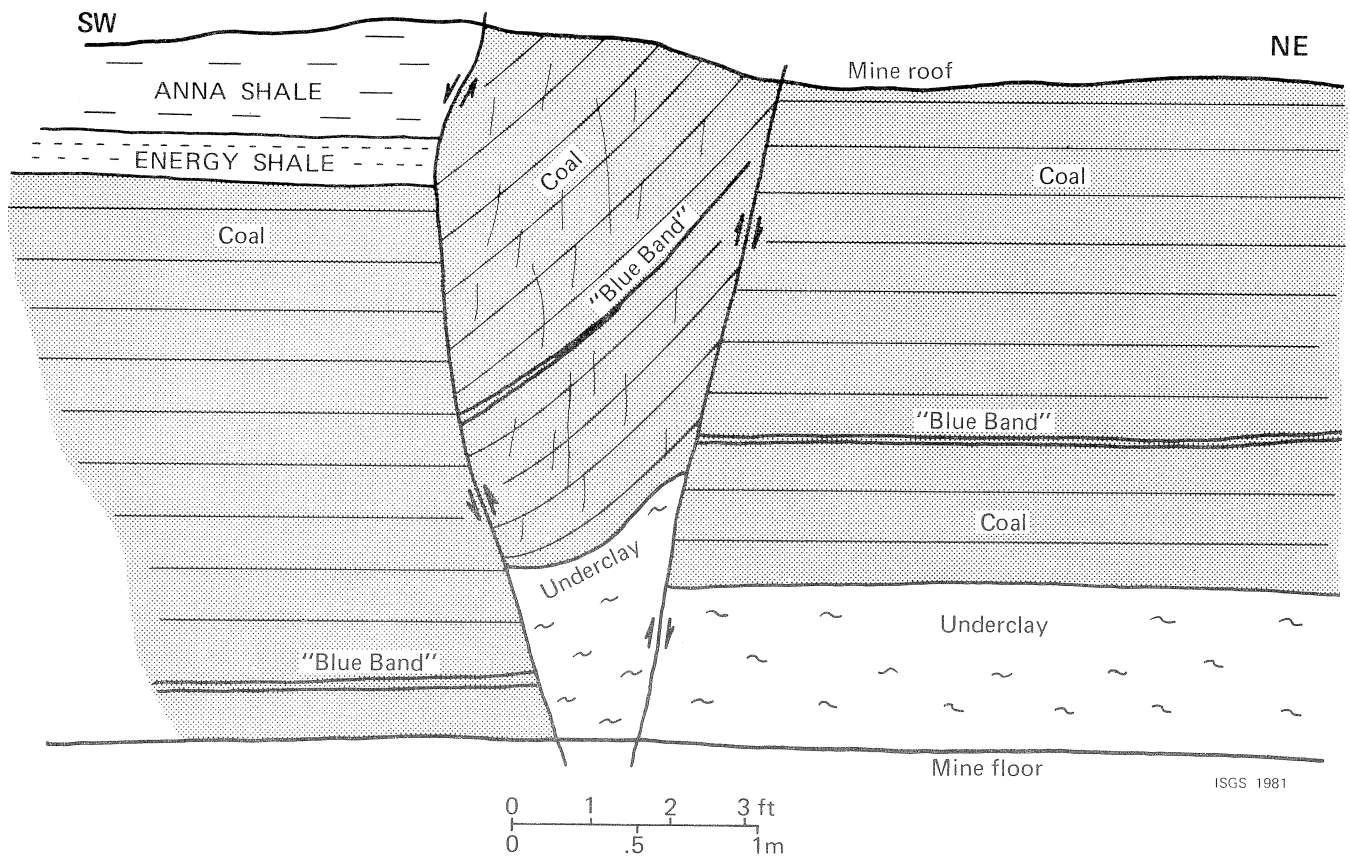

Figure 33. View looking northwest along strike of Fault "C" (fig. 28). Horizontal striations on fault planes indicate dominant strike-slip movement. The block between the two fault planes is upthrown, highly fractured, and tilted about 45 degrees to the southwest. The block was probably squeezed upward between the walls of the fault when lateral movement occurred.

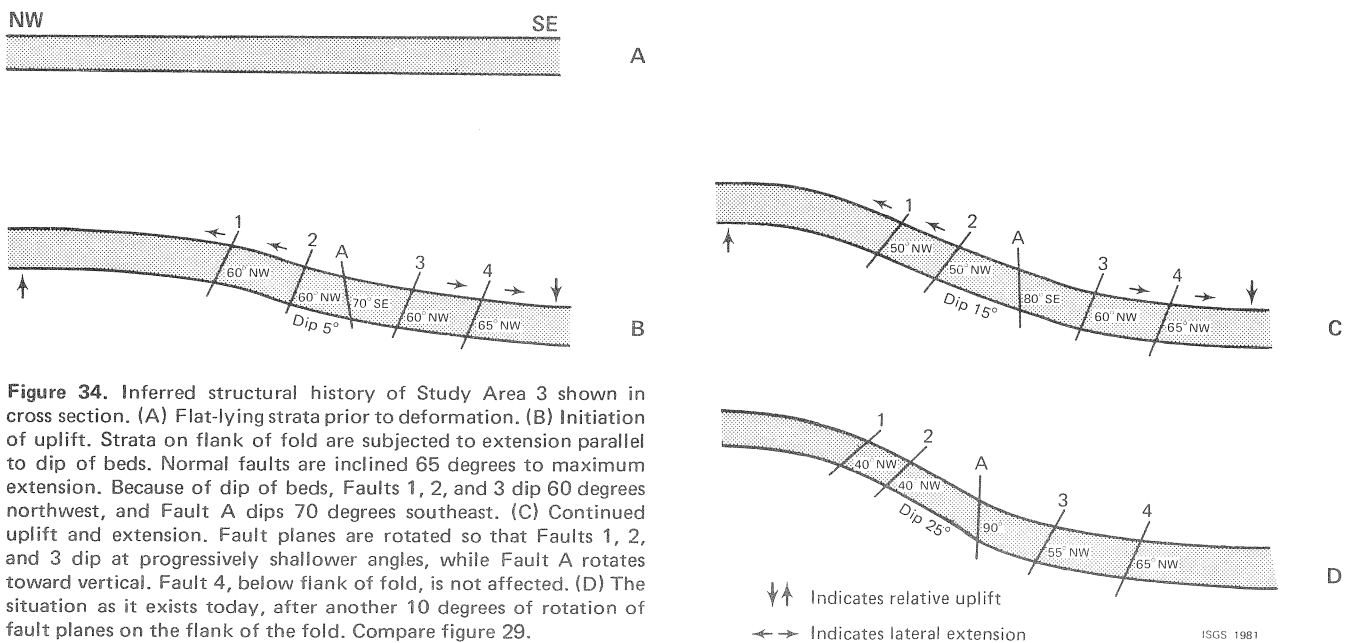

Figure 34. Inferred structural history of Study Area 3 shown in cross section. (A) Flat-lying strata prior to deformation. (B) Initiation of uplift. Strata on flank of fold are subjected to extension parallel to dip of beds. Normal faults are inclined 65 degrees to maximum extension. Because of dip of beds, Faults 1, 2, and 3 dip 60 degrees northwest, and Fault A dips 70 degrees southeast. (C) Continued uplift and extension. Fault planes are rotated so that Faults 1, 2, and 3 dip at progressively shallower angles, while Fault A rotates toward vertical. Fault 4, below flank of fold, is not affected. (D) The situation as it exists today, after another 10 degrees of rotation of fault planes on the flank of the fold. Compare figure 29.

↑↑ Indicates relative uplift
 ↔ Indicates lateral extension

ISGS 1981

Study Area 4

Study Area 4 (figs. 35 and 36) includes the Northeast Main Entries southwest of the slope and an adjacent section of the Main East Entries of the Orient No. 4 Mine, Freeman United Coal Mining Company. The study area is located in the southeast quarter of Section 26, Lake Creek Township (T. 8 S., R. 3 E). Four large faults and a multitude of small faults and structures were accessible for examination in Study Area 4.

The southwesternmost large fault in Study Area 4 ("A" in figs. 35 and 36) is a reverse fault striking southeast (145°) and dipping northeast (45°), with about 16 feet (4.8 m) displacement in the Herrin (No. 6) Coal. The strata lie horizontal on both sides of Fault "A," and there is virtually no drag. Very close to the main fault plane are a few small parallel normal faults.

Fractures in the roof shale perpendicular to Fault "A" are prominent on both sides of the fault for about 300 feet (90 m). Fractures parallel with the fault are common southwest of the fault but rare northeast of it. Most of the fractures are vertical planes with no visible displacement or slickensides, and they closely resemble ordinary joints as commonly seen in shale. However, some of the fractures are more intense than ordinary joints and affect the full height of the coal as well as the shale. The coal and shale are pulverized along these fractures, and small displacements and slickensided surfaces may be visible. The most intense development of such fractures was observed in an area about 300 feet (90 m) east of Fault "A."

Just east of Fault "A," a slickensided bedding surface was noted in the coal 2.7 feet (0.85 m) below the top of the seam. The striations trend northeast (40°) and the pattern of smoothness and irregularity on the fault surface seemed to indicate that the upper block moved toward the northwest. The amount of slip could not be determined. The slickensided plane ends against Fault "A" and does not offset it. No other indications of bedding-plane slippage were found in Study Area 4.

Northeast of Fault "A" are two parallel reverse faults, Faults "B" and "C," (figs. 35 and 36) which strike northwest and form a keystone-shaped horst near the crest of an asymmetrical anticline (fig. 36). The plane of Fault "B" dips steeply to the northeast, and the fault has about 15 feet (4.5 m) of dip slip. Fault "C" has 7 feet (2.1 m) of dip slip and a nearly vertical plane. Fault "B" shows almost no drag, but the strata on both sides of Fault "C" are folded downward (fig. 37).

The coal and associated strata are intensively fractured for about 400 feet (120 m) northeast and southwest of Faults "B" and "C." Most of the fractures are steeply dipping to vertical and strike parallel with Faults "B" and "C." Many have slickensides and thin zones of gouge, and some show small normal or reverse displacement. Nearly all

fractures southwest of Fault "B" dip northeastward, toward Fault "B." Fractures northeast of Fault "C" and fractures between the two faults dip either northeastward or southwestward. A few vertical fractures strike obliquely or perpendicular to the large faults (fig. 35).

Northeast of Fault "C" is a broad, shallow syncline in the coal, with numerous small normal faults and extensional fractures trending east-northeast (70°). The largest of these faults, Fault "D," has the northern side downthrown about 4 feet (1.2 m). Fault "D" and the associated fractures appear to represent a westward continuation of the normal faults from Study Area 3 (see plate 1).

A simplistic explanation of Faults "A," "B," "C," and the associated anticline is that they resulted from horizontal maximum compressive stresses oriented northeast to southwest. Such an idea would contradict the finding that nearly all the other northwest-striking faults in the Cottage Grove Fault System are extensional (normal) faults with only local and subordinate compressional structures. It also would require rethinking of the theory that the CGFS is a right-lateral wrench zone, in which maximum horizontal compression extended northwest-southeast and maximum horizontal extension ran northeast-southwest. However, we do not believe horizontal compression was the cause for Faults "A," "B," and "C."

Compression parallel with the earth's surface typically produces low-angle thrust faults; in homogeneous materials, shear fractures are inclined about 30 degrees to principal compressive stress (Billings, 1954). In contrast, Fault "A" dips 45 degrees, Fault "B" dips about 70 degrees, and Fault "C" is nearly vertical. Furthermore, most of the minor faults and fractures are steeply dipping and show normal movements; this indicates extension from northeast to southwest. The only low-angle fault in the study area is the slickensided bedding plane near Fault "A."

Having ruled out horizontal compression, we turn to localized uplift as an explanation for the structure in Study Area 4. A hypothetical cross section of the fault zone (fig. 38) illustrates how such localized uplift may have developed. Faults "A," "B," and "C" may connect at depth with a major vertical fault zone, along which strike-slip or oblique-slip movements occurred. Lateral or oblique movements along the zone may have squeezed the wedge-shaped slices upward, as shown. We have seen several small-scale examples of upthrown central slices along minor strike-slip and oblique-slip faults in the Cottage Grove Fault System (figs. 26 and 33).

Large-scale upthrust faults along wrench faults are known in California (Wilcox, Harding, and Seely, 1973). Support for lateral movements at depth in Study Area 4 is provided by the peculiar drag on Fault "C" (fig. 37), which is difficult to explain in terms of simple dip-slip movement.

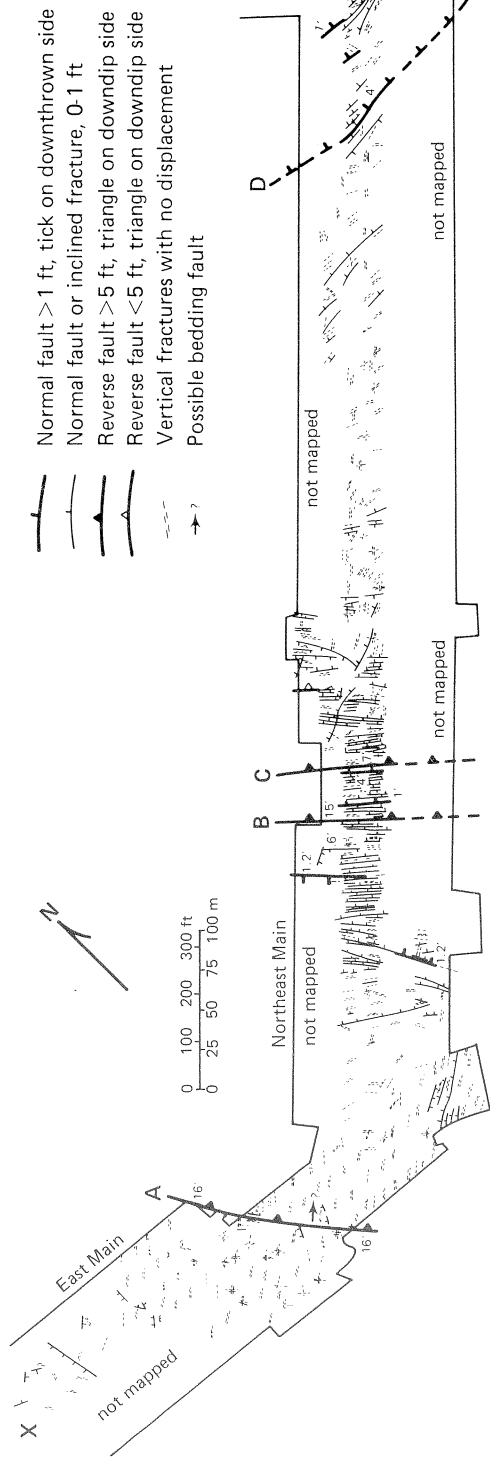

Figure 35. Faults in Study Area 4, Main East and Northeast Main Entries, Orient No. 4 Mine. Letters A, B, C, and D refer to features described in text. Compare this map with cross section (fig. 36). Note that mapping is incomplete; many areas are inaccessible because of roof falls.

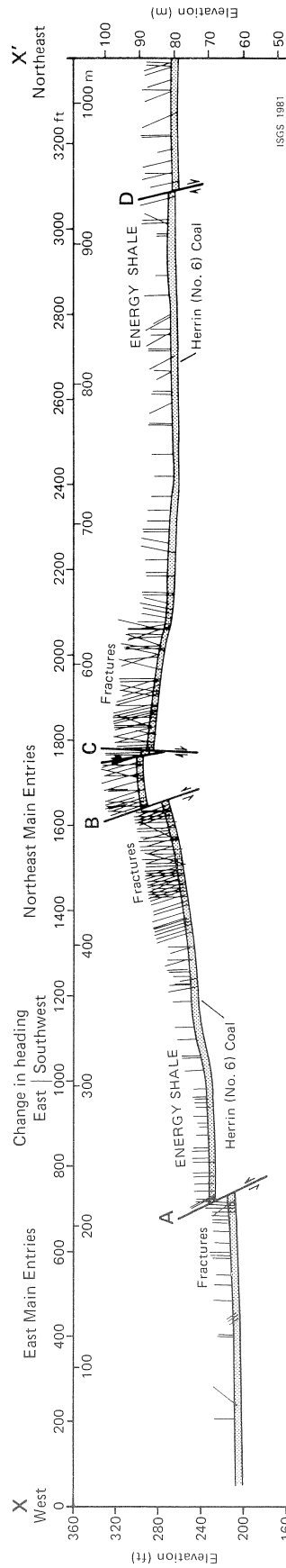

Figure 36. Cross section of Study Area 4. Compare with map of same area (fig. 35). Letters A, B, C, and D refer to features described in text.

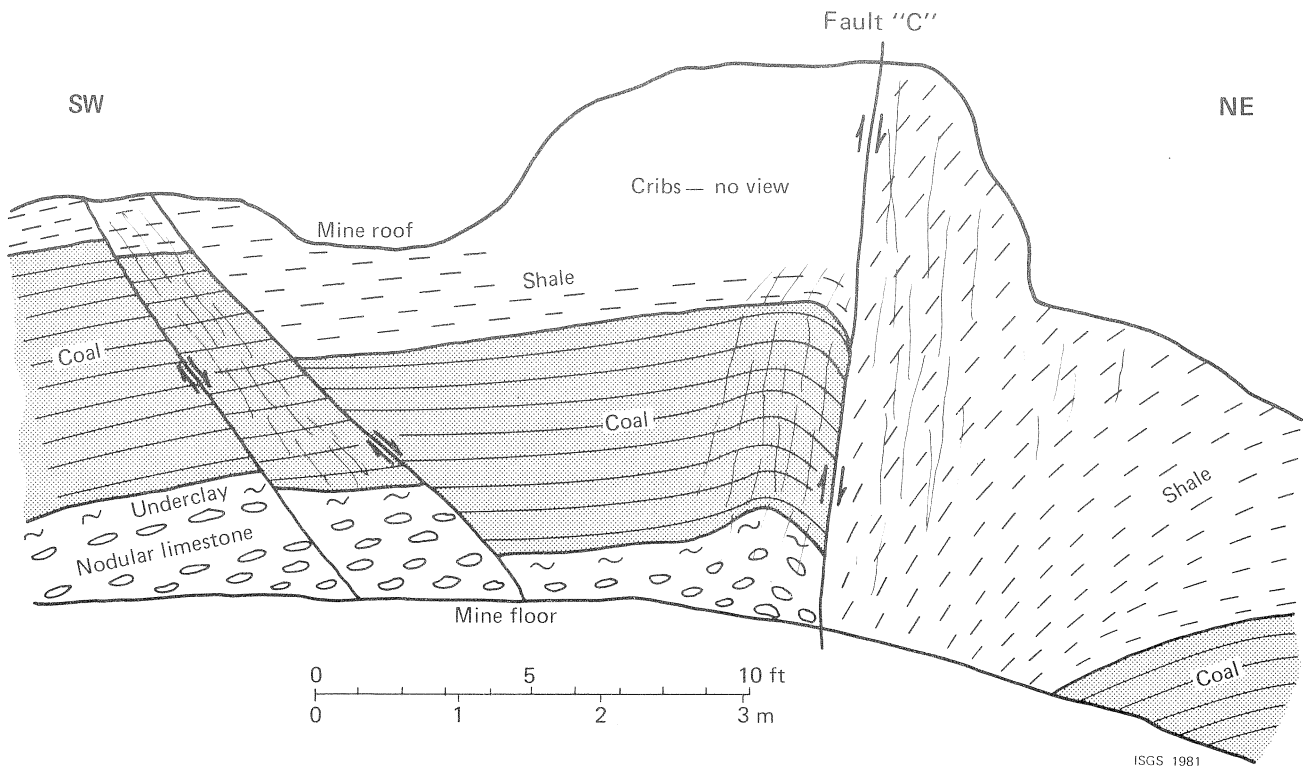

Figure 37. Fault "C" in Study Area 4, as exposed on northwest rib of travelway. The fault plane is essentially vertical and the northeast block is downthrown about 7 feet (2.1 m). The strata on both sides of Fault "C" are dragged sharply downward, indicating either successively reversed dip-slip movements or a component of strike-slip movement. The two small normal faults southwest of Fault "C" are antithetic to Fault "C."

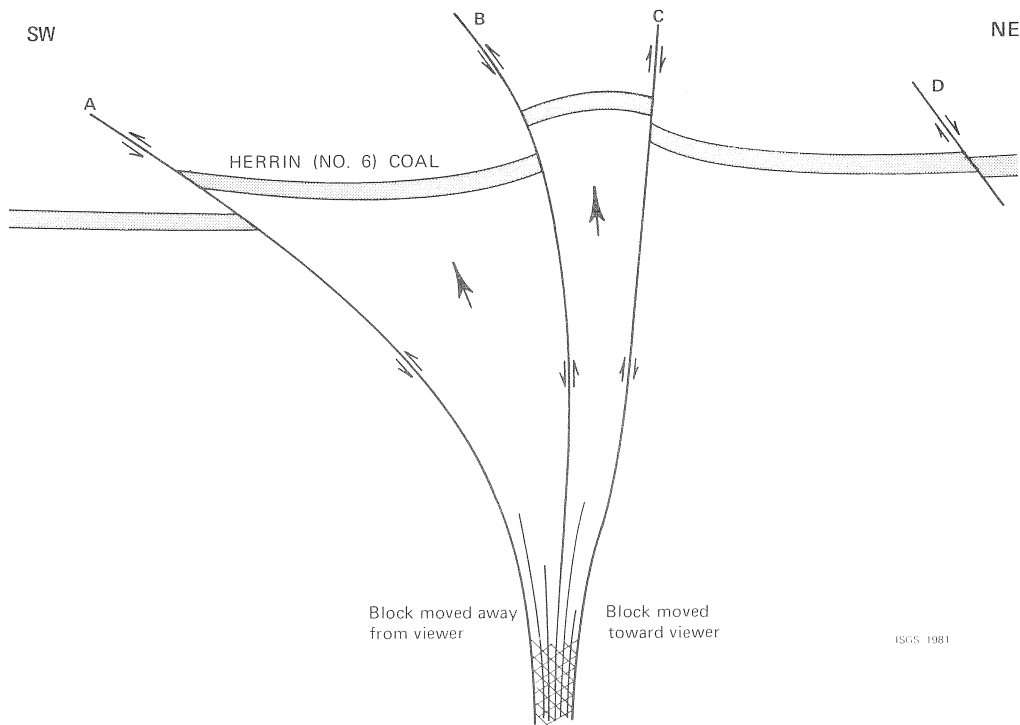

Figure 38. Hypothetical cross section illustrating origin of structure in Study Area 4. Faults "A," "B," and "C" are seen as merging at depth into an essentially vertical zone of right-lateral faulting, perhaps a segment of the master fault. Movements along the buried wrench fault caused upthrusting of slices within the zone. Localized upthrusting results in geometric reverse faults that typically decrease in dip toward the surface. Fault D, to the northeast, has a different origin and probably is genetically linked to the normal faults in Study Area 3.

- 9. — Normal fault > 5 ft; tick on downthrown side; throw in ft
- 1. — Normal fault 1-5 ft; tick on downthrown side; throw in ft
- 8. — Normal fault < 1 ft; tick on downthrown side (may include some nontectonic faults)
- 3. — Reverse fault > 5 ft; triangle on downdip side; throw in ft
- 4. — Reverse fault < 5 ft; triangle on downdip side; throw in ft
- Vertical fractures or joints in roof
- 8. — Shearing parallel to bedding; arrow in direction of movement of upper block; displacement in ft

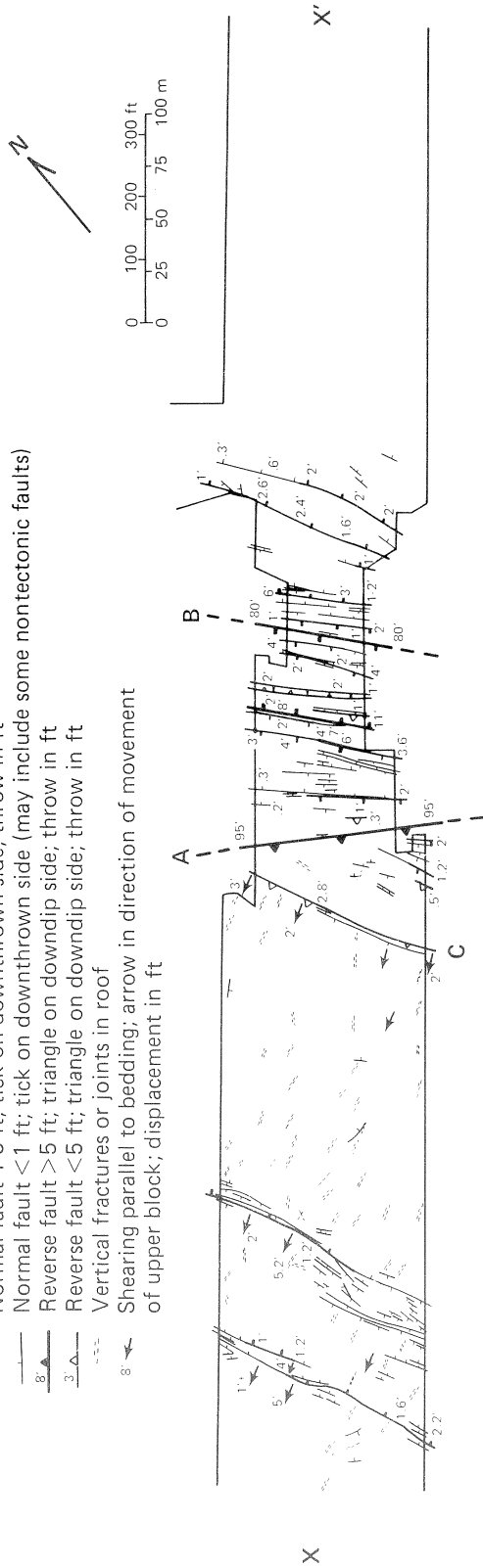
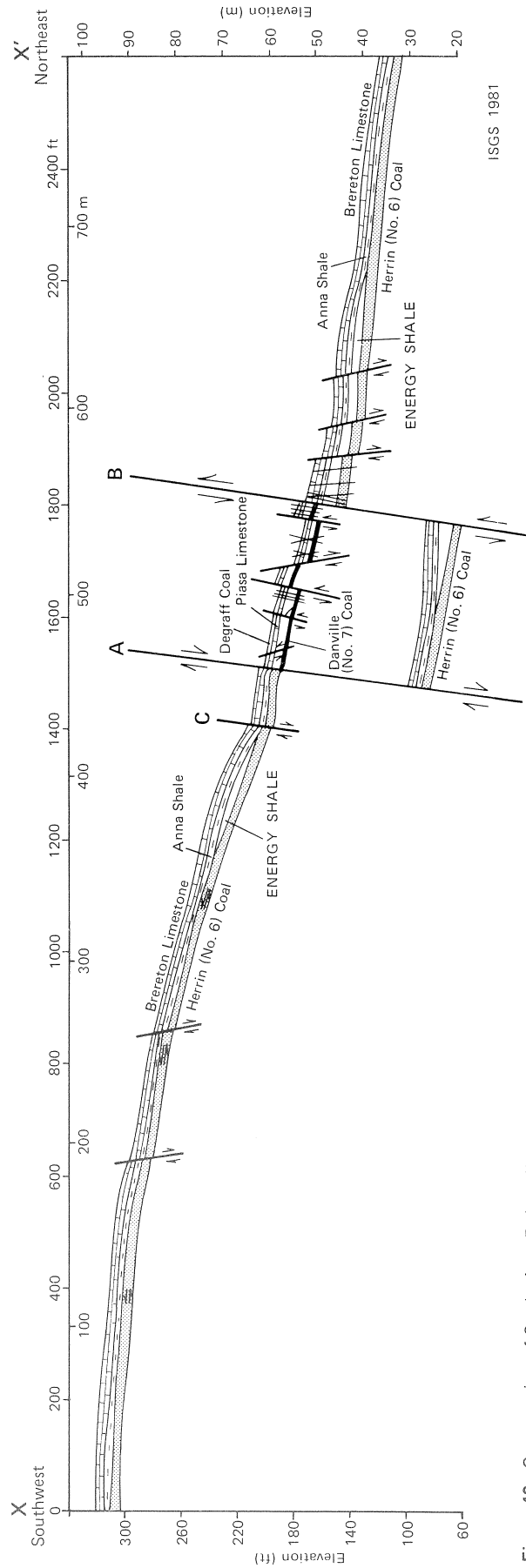

Figure 39. Faults in Study Area 5, 6th North off Southeast Mains, Orient No. 4 Mine. X-X' is line of cross section, figure 40.



ISGS 1981

Figure 40. Cross section of Study Area 5 along line X-X' in figure 39.

Study Area 5

Study Area 5 is in the northeastern part of the Orient No. 4 Mine in Section 19, Corinth Township (T. 8 S., R. 4 E.). The study area lies along the northeastern flank of the Pittsburg Anticline and contains a major fault zone that represents a transition from the west-northwest striking master fault zone to northwest-trending subsidiary faults.

As shown in figures 39 and 40, the largest faults in Study Area 5 lie along the base of the northeastern flank of the anticline, where the dip of the coal is 15 to 20 degrees. The two largest faults "A" and "B" form a graben with nearly parallel sides. The Herrin (No. 6) Coal is downthrown 80 to 100 feet (24 to 30 m); the mine entries in the graben are driven through rock approximately at the position of the Danville (No. 7) Coal. Numerous accompanying faults are found inside the graben and outside on both sides of it.

Fault "A" is a high-angle reverse fault striking east-southeast (120°) and dipping southwest (60° to 70°), with about 95 feet (29 m) of dip-slip displacement down to the north in the Herrin (No. 6) Coal. Gouge and breccia, consisting of angular fragments and blocks of rock in a clay-like matrix, occur within the fault zone. The width of the breccia varies from less than an inch to several feet. No slickensides have been found along fault "A."

The strata adjacent to Fault "A" display deformational features which indicate that other than simple dip-slip movements occurred. In one entry, strata on both sides of the fault are bent sharply to display simple drag (fig. 41). In an adjacent entry, however, strata abutting the fault are sharply dragged downward on both sides of the fault (fig. 42). Still a different pattern is seen in a third entry (fig. 43). Here the lower part of the Herrin Coal is bent downward on the hanging wall, but the upper part of the coal and the overlying shale and limestone are bent upward. On the footwall a ductile layer of dark gray shale is crumpled near the fault, and a thin band of concretionary limestone has been broken with the fragments thrust over one another in overlapping fashion.

Several explanations for the unusual pictures of deformation are possible: (1) The direction of movement on the fault was twofold, first normal and then reverse. (2) The fault is a simple reverse fault caused by compressional stresses at right angles to the fault. These same stresses crumpled and squeezed the strata near the fault. (3) The fault is a strike-slip fault, with only incidental vertical offset. (4) The fault is a tensional structure, formed in a field of right-lateral wrenching stresses. The walls of Fault "A" and Fault "B" were pulled away from each other, and the central block between the two faults collapsed. During the final phase of faulting the walls of the faults came back together; thus the strata near the faults were compressed perpendicular to the fault plane.

Alternative 1 is unlikely because if the second stage of movement were compressive (reverse), the compressive

drag should have obliterated most or all of the original, extensional drag. Alternative 2 is difficult to support because of the close juxtaposition of numerous parallel normal faults with Fault "A." Alternative 3 at first is attractive but does not account for the fact that the axes of the drag folds are horizontal, or nearly so. Drag folds along a strike-slip fault should have nearly vertical axes. We favor alternative 4. Fault "A" lies within the extensional portion of the right-lateral stress field of the Cottage Grove Fault System.

Fault "B" (figs. 39 and 40) is geometrically a normal fault trending $140/75^\circ$ southwest, and it has about 80 feet (24 m) of throw. It displays very little drag, no slickensides, and only a thin zone of gouge and breccia. Poor exposure in the mine prohibits detailed study of associated features.

The graben between faults "A" and "B" is about 320 feet (97 m) wide where the mine entries penetrate. Many small subordinate faults within the graben strike parallel

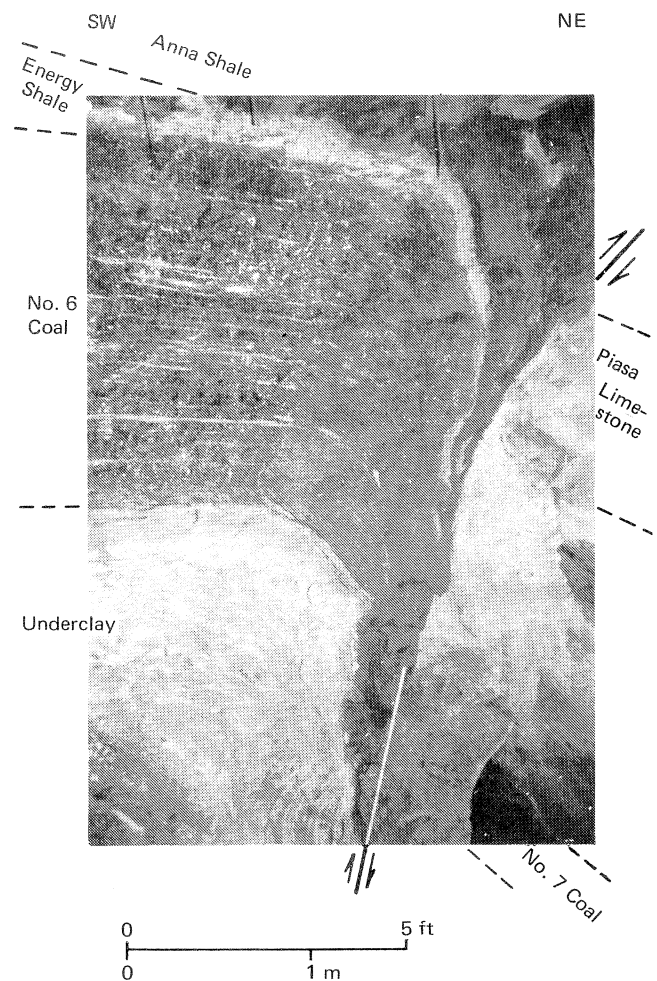

Figure 41. Fault "A" on southeastern entry of Study Area 5. At upper left is the Herrin (No. 6) Coal upthrown on the hanging wall and exhibiting prominent normal drag. The Danville (No. 7) Coal at lower right, and the adjacent strata, also are folded in normal drag. From this one exposure one might conclude that Fault "A" is a simple upthrust or reverse fault.

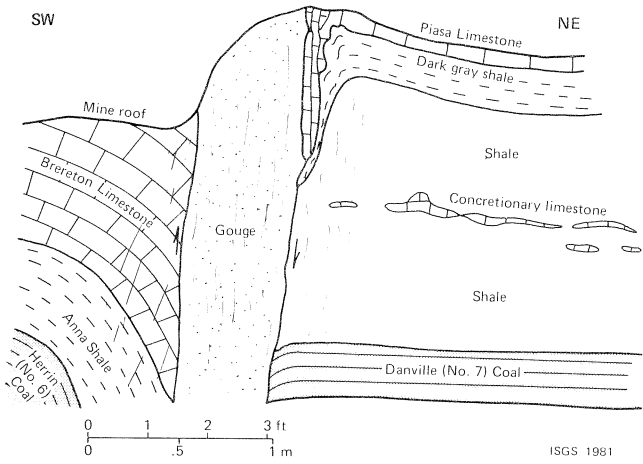

Figure 42. Fault "A" in middle entry of Study Area 5. Strata on both sides of the fault are dragged sharply downwards. The drag on the northeast block thus opposes the direction of dip-slip movement on the fault. This exposure shows that Fault "A" is not a simple reverse fault.

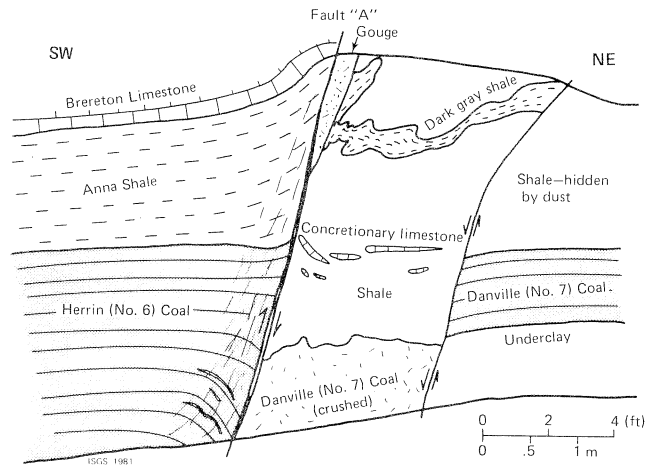

Figure 43. Fault "A" along northwestern entry of Study Area 5. Southwest of the fault the Herrin Coal is dragged downward, but the overlying units are dragged upward, opposite the direction of dip slip. Northeast of the fault the rocks appear to be crushed horizontally against the fault plane. The Danville (No. 7) Coal has been pulverized by this action; the thin concretionary limestone has been thrust over itself along tiny overlapping faults, and the dark gray shale near the top of the entry has been contorted into tight folds. Simple horizontal compression or simple upthrusting cannot account for the structure shown above.

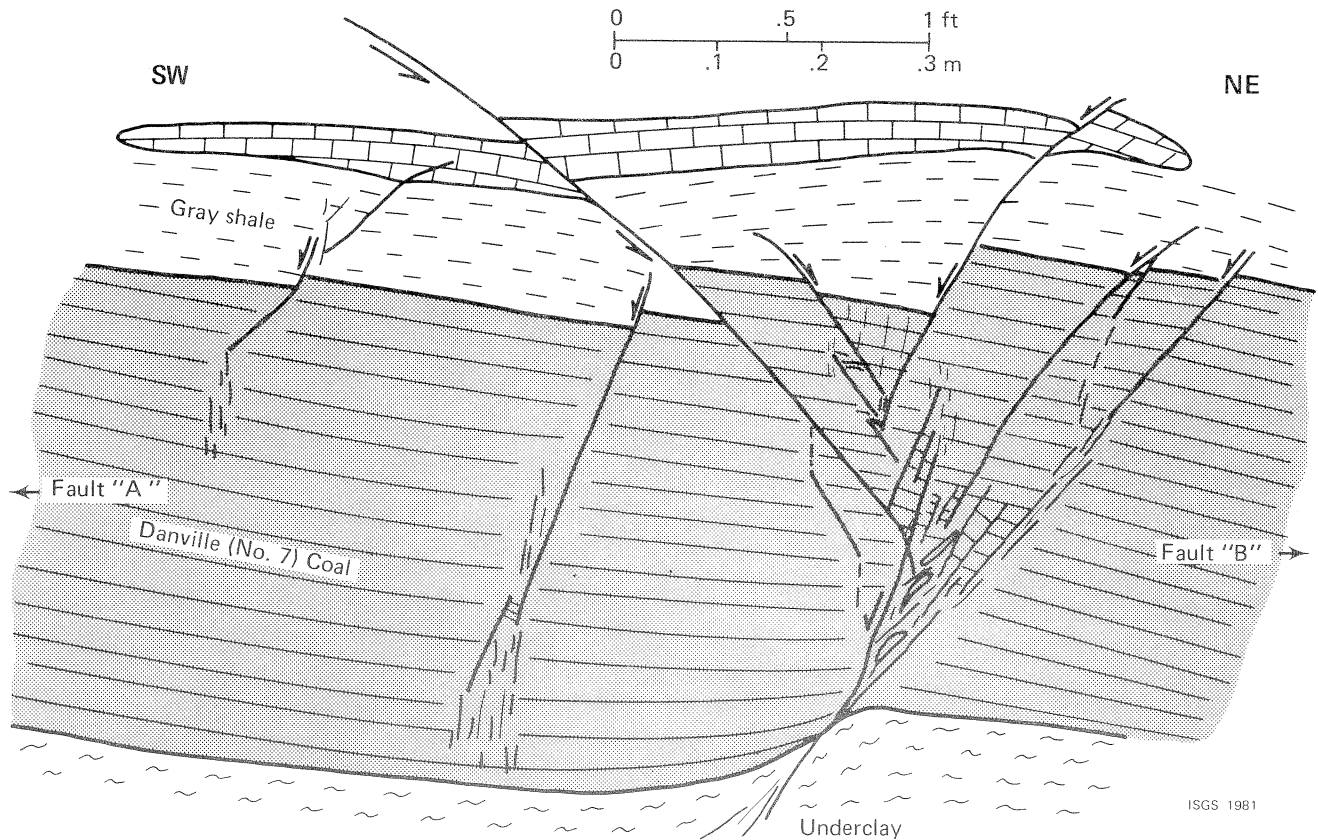

Figure 44. Minor structures within graben between Faults "A" and "B" in Study Area 5. A series of open extensional fractures and small normal faults have developed in the Danville (No. 7) Coal. A low-angle reverse fault truncates one normal fault and terminates against another. The close association of extensional and compressional structures reflects a complex structural history, probably involving oblique-slip movements along the major faults as well as wedging or rotation of the blocks adjacent to major faults.

to Faults "A" and "B." The majority of the subordinate faults are high-angle normal faults, but a few low-angle reverse faults are also present (fig. 44). Along strike some faults change from normal to reverse. No clear indications of strike-slip faulting were found within the graben.

Northeast of Fault "B" the inclination of the Herrin (No. 6) Coal rapidly decreases, and the intensity and density of subordinate faults quickly diminishes. All subordinate faults in this area are normal faults that strike parallel with Fault "B." Most of them are antithetic faults dipping away from Fault "B" and having the northeast side downthrown. No faults were found beyond 300 feet (90 m) from Fault "B."

On the other side of the graben, southwest of Fault "A," many faults penetrate the steeply dipping northeast flank of the Pittsburg Anticline. Most of these minor faults strike south-southeast (160°), roughly parallel with the axis of the anticline and slightly oblique to Fault "A." The majority are high-angle normal faults dipping either to the west or to the east. Reverse displacements are recog-

nized on Fault "C" and on a few other minor faults near Fault "A." Vertical fractures (joints) in the shale above coal strike roughly perpendicular to the faults and are prevalent throughout the area.

Shearing parallel to bedding is prominent in the area southwest of Fault "A." Most commonly one bedding-plane fault near the middle of the seam was found, but in some places several such shear planes parallel to bedding are visible within the coal or at the interface of coal with roof or floor. The bedding-plane faults commonly follow clay partings or other planes of weakness in the seam. In most places they are marked by thin layers of pulverized coal, easily mistaken for partings of fusain. Locally the gouge zones of bedding-plane faults thicken to an inch (2.5 cm) or more and contain a breccia of folded or rotated chunks of coal in a matrix of clay and finely crushed coal. In places small folds were noted along the bedding-plane shears.

The bedding-plane faults truncate and displace high-angle normal and reverse faults (fig. 45). In every case that

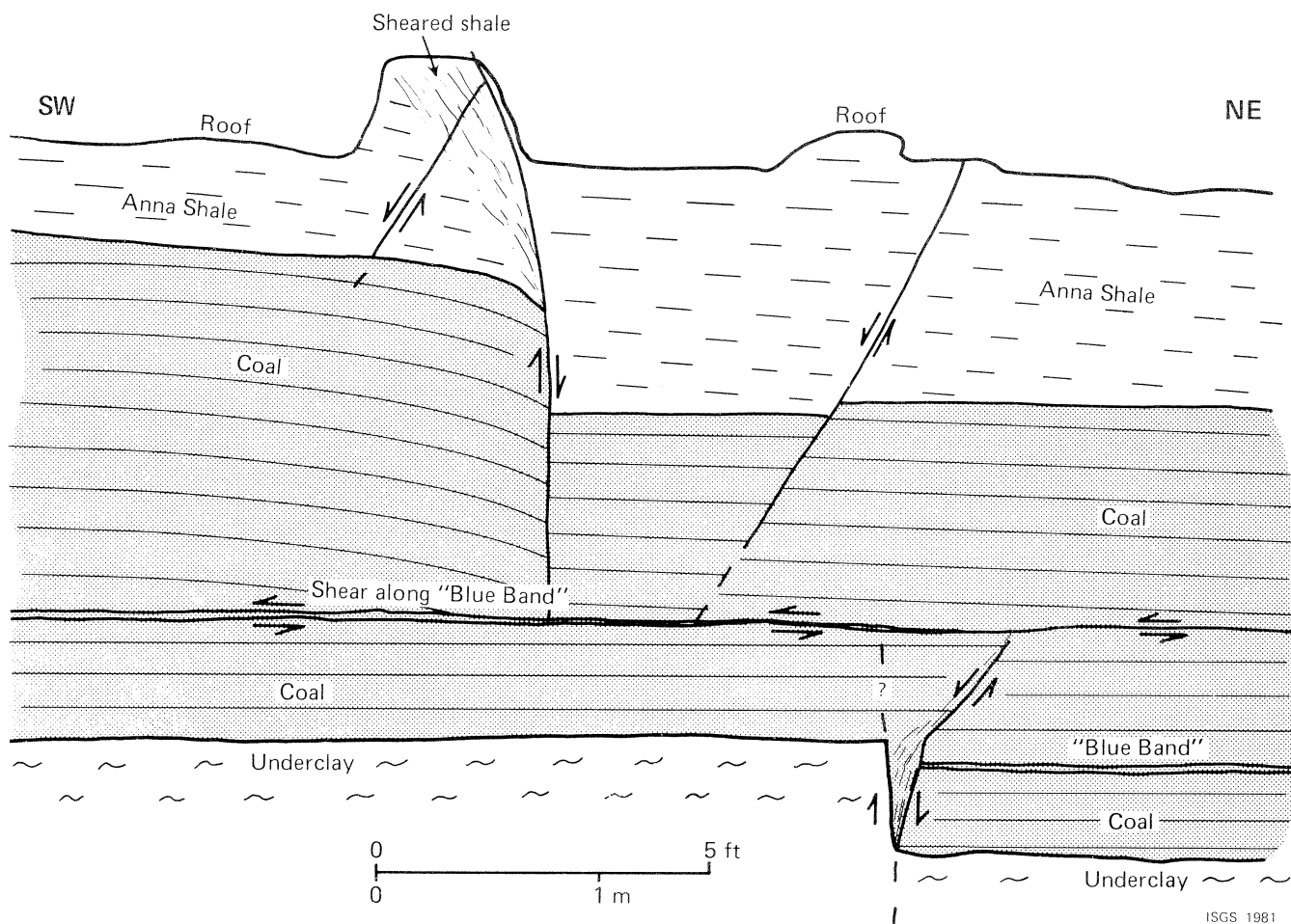

Figure 45. Bedding-plane fault offsetting high-angle faults southwest of Fault "A" in Study Area 5. The bedding-plane shear has followed the "Blue Band," a persistent layer of clay near the base of the Herrin (No. 6) Coal. In this example the apparent horizontal offset is 5.2 feet (1.58 m) with the upper block having moved updip, toward the southwest. The net slip may be greater than the apparent slip, which was measured along the rib of coal. Nearly all bedding-plane faults in Study Area 5 are younger than high-angle faults and show the upper block moved toward the southwest.

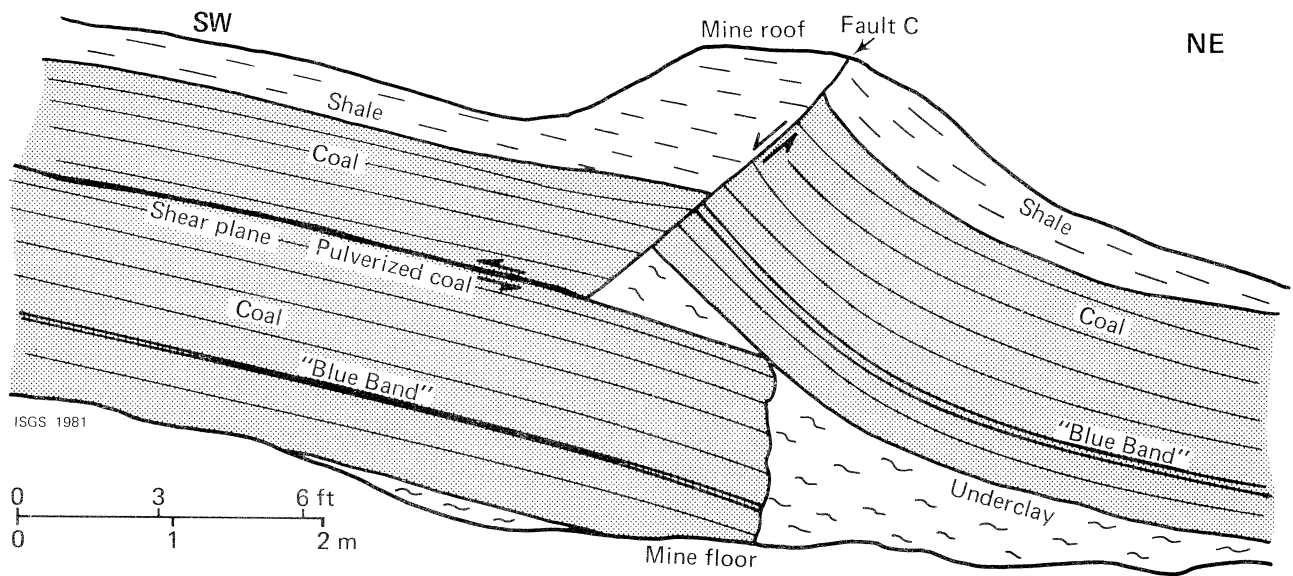

Figure 46. Intersection of Fault "C" and bedding-plane fault in coal in Study Area 5. The lower block of the bedding-plane fault appears to have been shoved under the footwall of Fault "C" and forced the latter upward. The bedding-plane fault may continue to the northeast through the underclay. Whether the bedding-plane shear is younger than Fault "C" or whether both formed in the same action is not certain.

was observed the block below the bedding fault moved relatively toward the northeast, down slope. The maximum apparent horizontal displacement observed was 5.2 feet (1.6 m), measured along the rib, which trends northeast. If the actual direction of movement was not directly northeast, the true displacement is greater than 5.2 feet (1.6 m).

The superimposition of bedding-plane shearing on vertical movements along normal and reverse faults has produced some unusual structures along Fault "C." The surface of Fault "C" strikes south-southeast (160°) and consistently dips toward the southwest, but the direction of throw undergoes "scissoring" along strike. In some places the northeast block moved relatively upward, creating a normal fault, and elsewhere the southwest block is upthrown, forming a reverse fault. In still other places the coal is intensely folded and fractured along Fault "C," but only slight vertical offset has taken place.

In one entry Fault "C" appears geometrically as a normal fault that has been offset along a bedding-plane fault (fig. 46). Southwest of Fault "C" the Herrin Coal dips uniformly to the northeast and the bedding-plane shear lies in the upper part of the coal. Northeast of Fault "C," the coal is bent upward so that the entire seam and a portion of the underclay override the bedding-plane fault. One interpretation of this structure is that Fault "C" was formed first and was later offset by slippage along bedding. The block of coal below the bedding-plane fault, moving northeastward, was shoved beneath the footwall of Fault "C" and buckled the latter upward. An alternate explanation is that all the structure formed in one action. The block beneath the bedding-plane shear met resistance to movement, probably at Fault "A," and was jammed backward; the coal buckled upward and ruptured at Fault "C."

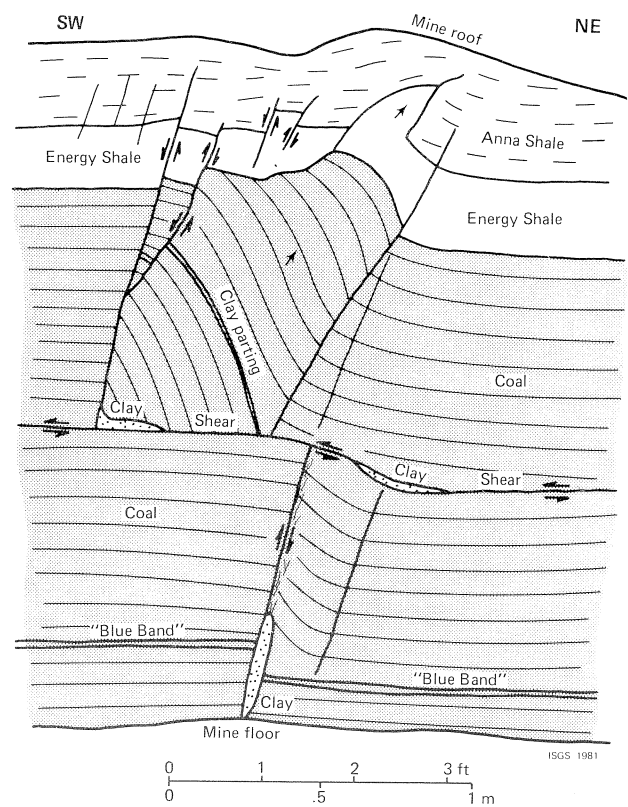

Figure 47. Complex structure formed at intersection of Fault "C" and bedding-plane fault in Study Area 5 on an entry southeast of that shown in previous figure. Fault "C" comprises a sharp flexure broken by a series of small normal and reverse faults. It is definitely offset along the bedding-plane fault. (The fact that structures above and below the bedding-plane fault do not match may reflect a component of horizontal movement toward the observer.) The bedding-plane fault itself has been folded near the center of the drawing. This observation suggests that all the deformation shown in the sketch is essentially contemporaneous.

In an adjacent entry a much different structural pattern is seen on Fault "C" (fig. 47). The coal is bent into a sharp flexure that is broken by numerous small normal and reverse faults. A bedding-plane fault near the middle of the coal offsets the faulted flexure about 3 feet (0.9 m). The bedding-plane fault itself is gently folded; this indicates that vertical movement partially post-dated horizontal slippage at this location.

Faulting parallel to bedding planes can be produced by a variety of mechanisms, one of which is gravitational sliding in incompletely lithified sediments. Such an explanation is not applicable, however, to the bedding-plane faults in Study Area 5. The coal is pulverized along the bedding-plane faults and so must have been lithified when slippage took place. The bedding-plane faults offset normal and reverse faults, which themselves display entirely brittle deformation. Furthermore, faults due to gravitational sliding rarely are confined to bedding planes but commonly transect bedding and may produce a chaotic structure (Krause, Nelson, and Schwalb, 1979).

Slippage along bedding planes commonly accompanies folding. Conceivably the bedding-plane shearing in Study Area 5 developed in response to formation of the Pittsburg Anticline. However, flexural slip on folds generally is distributed as minute adjustments over numerous bedding surfaces rather than being expressed as large displacements on only a few bedding planes.

We believe the origin of bedding-plane faults in Study Area 5 is directly related to the origin of the larger faults in the area. Our interpretation (fig. 48) is consistent with the view that the Cottage Grove Fault System was a zone of right-lateral wrenching.

Probably the arching of the Pittsburg Anticline began prior to any faulting. The folding is believed to have been a gradual process that may have continued throughout structural development. Some of the small normal faults in Study Area 5 may be antithetic faults, formed in response to tensional forces on the flanks of the rising anticline (fig. 48B)

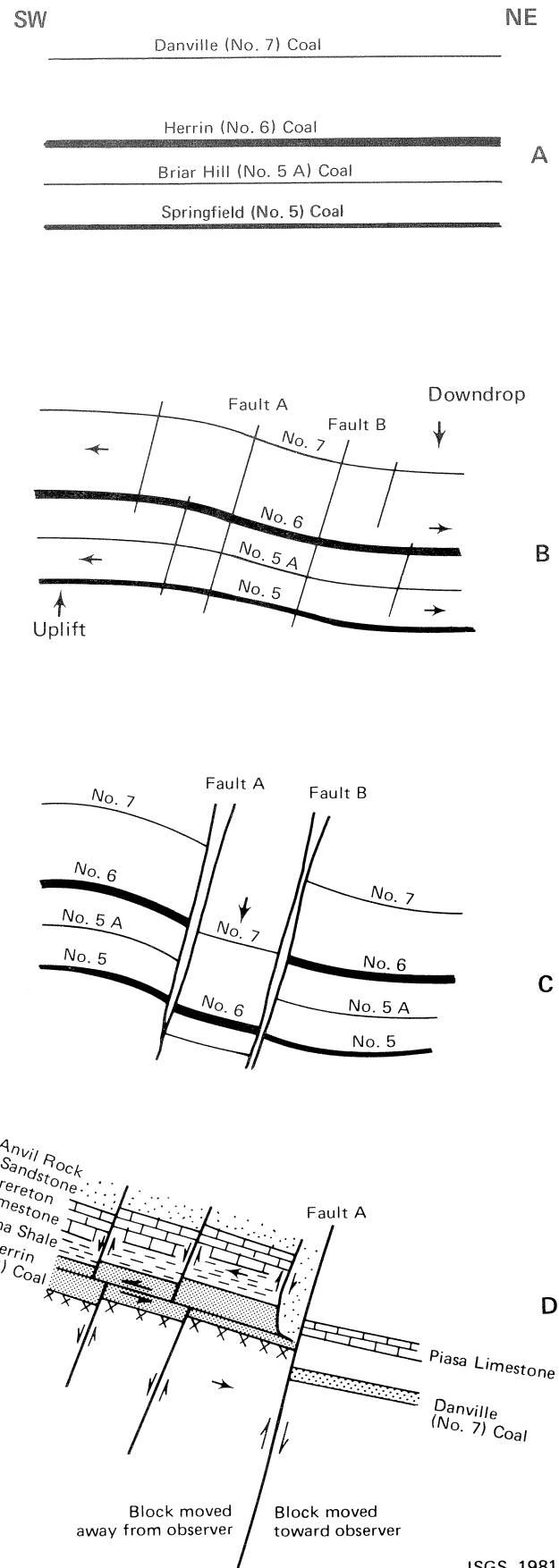

Figure 48. Hypothetical structural history of Study Area 5. (A) Horizontally-layered strata prior to deformation. (B) Initiation of uplift produces monoclinal fold (north limb of Pittsburg Anticline). At the same time horizontal extension produces southwest-dipping normal faults similar to those of Study Area 3. (C) Continued extensional stresses, perhaps accompanied by right-lateral wrenching, pulls the walls of Faults "A" and "B" away from each other, momentarily forming open voids along both faults. The block between the two faults subsides to produce a graben. (D) Detail of Fault "A" showing possible mode of origin of bedding-plane fault. When the walls of the fault pulled apart a slice of rock slid down and wedged in the void, blocking the upper part of the coal from coming back against the fault. The lower part of the coal and underlying strata were able to break free along a bedding plane and close the void below the down-dropped slice.

An alternative explanation of the bedding-plane faults is that they developed in response to the horizontal twisting stresses imparted to the stack of strata by strike-slip movements along the buried master fault.

ISGS 1981

The major faults, "A" and "B," probably resulted from horizontal extension at right angles to the faults, that is, from northeast to southwest (fig. 48B). During extension the block of strata between Faults "A" and "B" subsided to form a graben (fig. 48C), while the blocks outside the faults remained stable. We believe that the walls of Faults "A" and "B" were pulled away from each other, temporarily producing open fissures. Once open space existed along Fault "A," tilted layers southwest of the fault were free to slide along bedding planes and fill the fissure. This process may have been repeated several times, with recurrent movements on Faults "A" and "B." As layers slid into the fault zone, the rocks near the point of collision crumpled to produce the peculiar "drag folds" shown in figures 41, 42, and 43. Some degree of strike-slip movement probably also occurred, but it need not have exceeded the dip slip in magnitude.

Folding on the Pittsburg Anticline may have continued after the major episodes of faulting. Continued folding would account for the fact that Fault "A," here presumed to be a tensional fault, geometrically appears to be a reverse fault. We suggest that Faults "A" and "B" originally were vertical and later were tilted so that they assumed a south-westerly dip.

Study Area 6

Study Area 6 includes a portion of the Main East Entries of Zeigler Coal Company Mine No. 4, in the Herrin (No. 6) Coal. The study area is in the southeast quarter of Section 9, Lake Creek Township (T. 8 S., R. 3 E.). Study Area 6 lies northwest of Study Area 5 along the Pittsburg Anticline and includes one large and numerous small northwest-trending subsidiary faults.

The study area encompasses part of the northwest anticlinal flank (figs. 49 and 50). The elevation of the Herrin (No. 6) Coal drops approximately 200 feet (60 m) from the western edge of the area to the eastern edge, a horizontal distance of 3,200 feet (975 m). Inclination of the coal within the study area averages 5 degrees and locally reaches 17 degrees. The structure of the coal is quite irregular, with numerous small rises and depressions on the flank of the larger fold. The small irregularities are not shown in figure 50 because the profile is based on elevations surveyed at 100-foot (30 m) intervals.

The largest fault in Study Area 6, Fault "A," strikes south-southeast (150°) and dips northeast (70°); it is slightly oblique to the elevation contours in the coal, which trend roughly southeast (135°). Fault "A" is geometrically a high-angle reverse fault with the northeast side upthrown about 32 feet (9.7 m). Thus, the upthrown block of the fault lies downdip on the fold. Maps prepared by engineers at Ziegler Coal Company show that Fault "A" continues about a mile (1.6 km) northwest of the study area and for a shorter distance to the southeast. Fault "A"

is a part of a set of subsidiary faults which form an en echelon pattern.

Exposures of Fault "A" are limited, so few details of its structure are known. Strata near the fault are strongly folded; locally the bedding is vertical in the fault zone. The zone of gouge is narrow, and no slickensides were observed. No definite indications were found for other than dip-slip movements on Fault "A."

Many small faults and fractures accompany Fault "A." The primary orientations are parallel with Fault "A" and perpendicular to Fault "A" (fig. 49). More small faults have been mapped northeast of Fault "A" than southwest of it, but this largely reflects the better quality of exposures to the northeast. Entries northeast of Fault "A" were mined within the coal, which shows small fractures well; entries southwest of Fault "A" were largely graded through the Energy Shale, in which faults are hard to distinguish.

Faults parallel with Fault "A" are mainly high-angle normal faults and a few small high-angle reverse faults. The largest displacement measured is 5.5 feet (1.7 m) on Fault "B" (figs. 49 and 50). Faults perpendicular with Fault "A" likewise are mostly high-angle normal faults, and none have more than 1 foot (0.3 m) of throw. Steeply dipping to vertical fractures with no measurable offset are numerous on both sides of Fault "A" and trend at right angles to it.

Fractures with indications of strike-slip movement were observed in several locations in Study Area 6. Some of these strike obliquely to Fault "A" (location C in fig. 49). These fractures have nearly vertical surfaces, curved in places, and bear prominent horizontal striations. The amount of dip slip is negligible, and the direction and magnitude of strike-slip movement could not be determined. Since these fractures can only be traced for short distances along strike, their displacement probably is slight.

Just southwest of Fault "A" (location E on fig. 49) is an area of complicated structure, which we have presented in an enlarged map (fig. 51). Here the mine entries were driven through roof strata of the Herrin Coal to maintain the grade through Fault "A." The top of the entry is the base of the Breerton Limestone, and ribs (walls) are composed of black, fissile Anna Shale overlying soft, medium gray Energy Shale. The coal is about 25 feet (8 m) below the floor of the entries. Faults are very clearly marked by offsetting of distinctive rock layers.

Two sets of faults are present in figure 51, one set roughly parallel and the other set roughly perpendicular to Fault "A." The parallel faults include high-angle normal and reverse faults with as much as 2 feet (0.6 m) of throw. The perpendicular faults show up to 1.5 feet (0.45 m) of dip slip and have nearly vertical planes. These faults also have components of left-lateral strike slip ranging from a few inches to about 5 feet (0.1 to 1.5 m). The perpendicular faults offset the parallel faults, and therefore the former are younger than the latter.

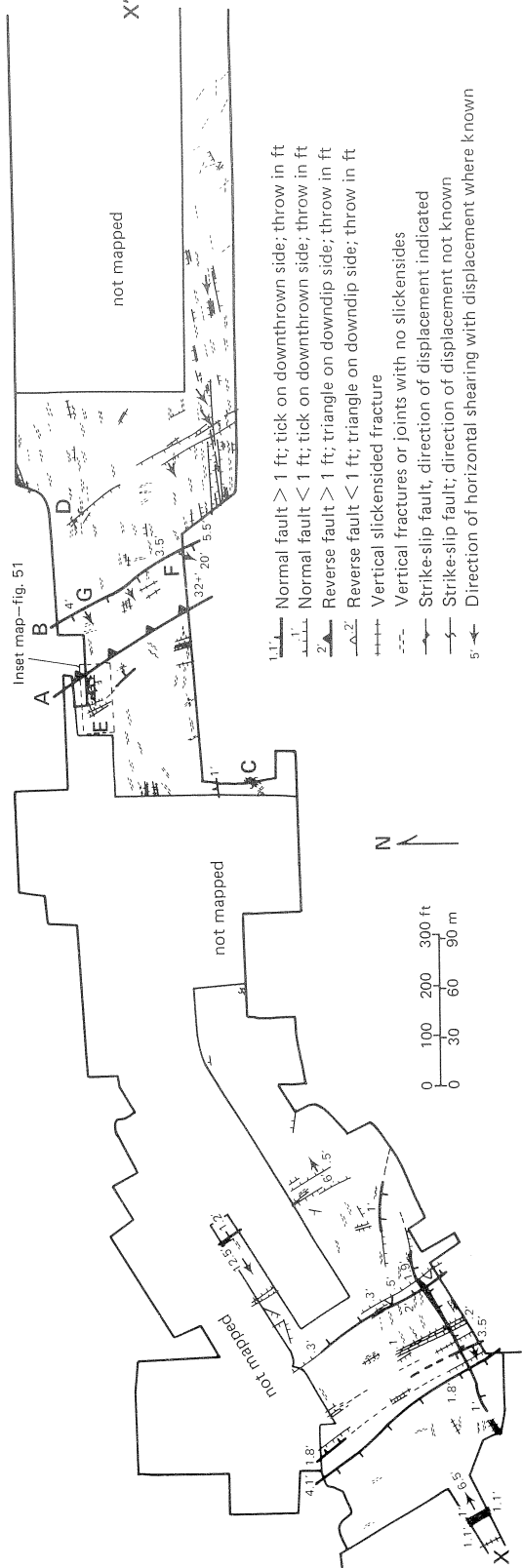

Figure 49. Faults and related structures in Study Area 6, Main East, Zeigler Coal Co., Mine No. 4. Mapping is incomplete because of poor accessibility and visibility in many places in the mine. Letters A-G refer to features described in text. Compare this figure with cross section (fig. 50).

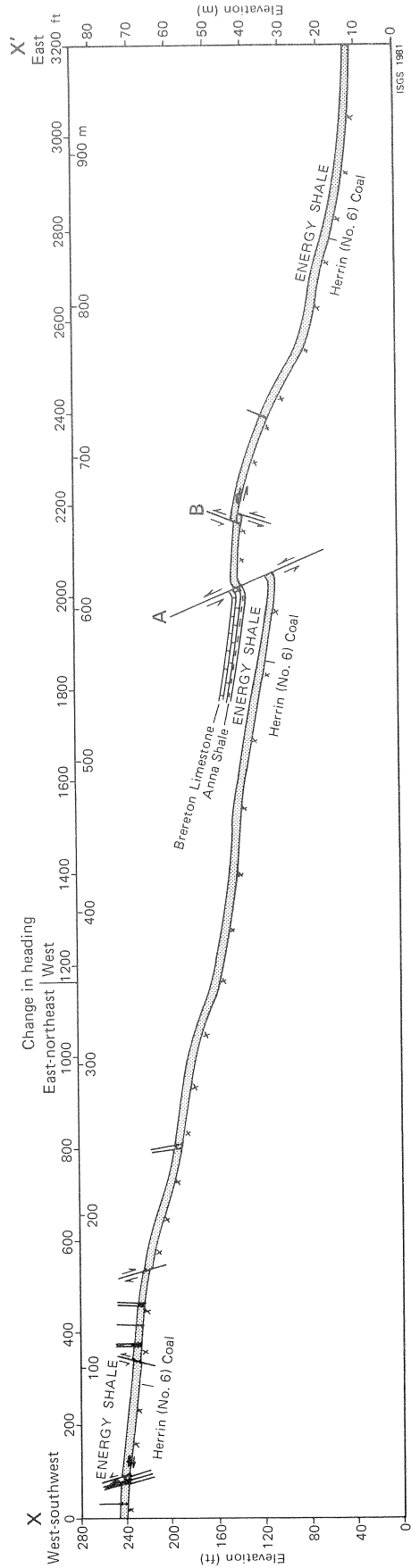

Figure 50. Cross section of Study Area 6. Compare with figure 52. Surface of coal is actually quite irregular, much more than shown here. (Data from mine survey elevations.)

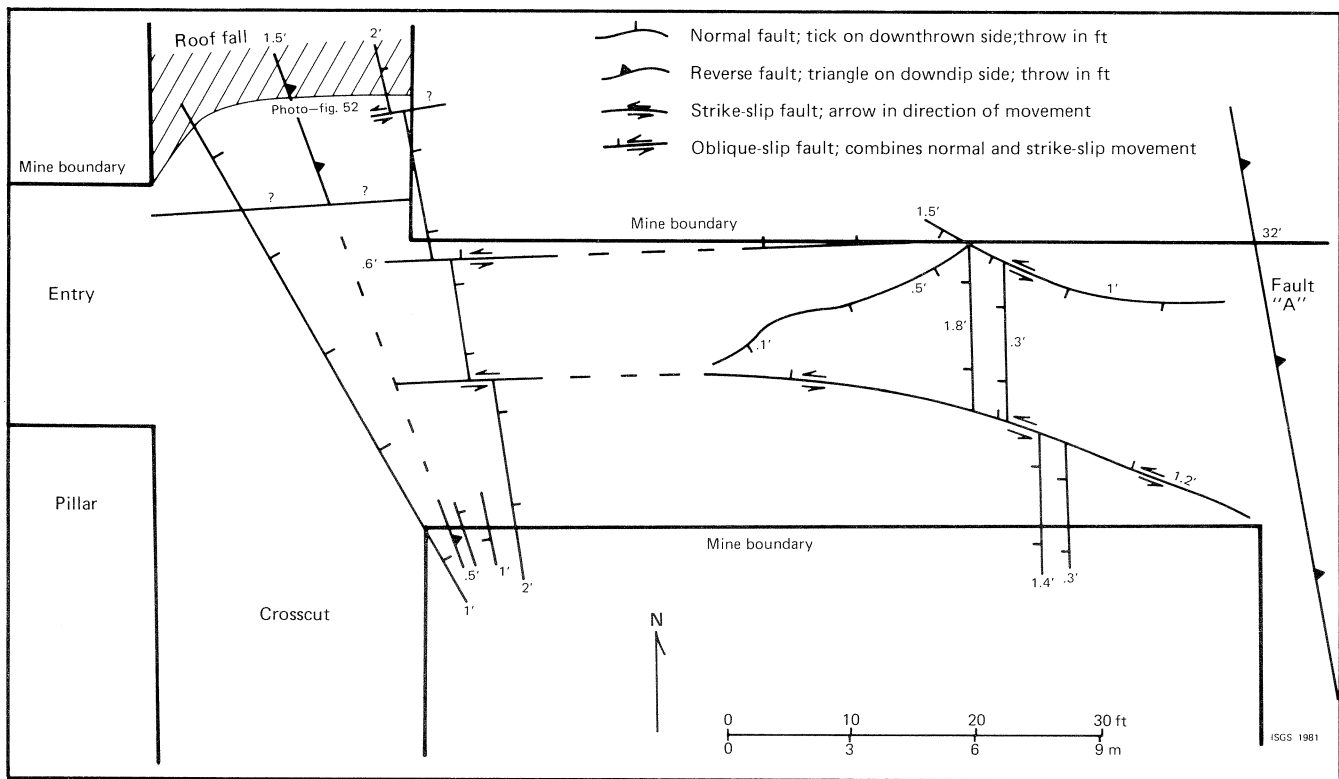

Figure 51. Enlarged map of a small portion of Study Area 6, Area E in figure 49. Two sets of faults were mapped, one set approximately parallel and the other set approximately perpendicular to Fault "A." The parallel faults are dominantly normal but some are reverse and may have a component of strike-slip motion as well. The perpendicular faults are small left-lateral faults offsetting and therefore younger than the parallel faults. With respect to Fault "A," they can be considered second-order conjugate shears.

Some of the parallel faults display peculiar deformational features (fig. 52). The Anna Shale is folded sharply downward along several faults. The folding is opposite the sense of dip slip (reverse drag) and in some cases is greater in magnitude than the amount of dip slip. On one fault, which has 1 foot (0.3 m) of dip slip, a thin wedge of crushed Anna Shale was found 10 feet (3 m) below the base of that unit on the footwall of the fault (fig. 52). Either this fault has a large component of strike slip, or (more likely) it is an extensional fault whose walls were pulled away from each other to allow a sliver of Anna Shale to drop into the open void.

Bedding-plane faults are found throughout the mapping area and in places have produced striking structural effects. One or several bedding-plane faults may be found within the coal seam. Where the fault zones are thin, the film of pulverized coal is easily mistaken for a layer of fusain, but in some places bedding-plane slippage has produced zones of crushed coal as much as 2 feet (0.6 m) thick. The faults commonly follow the "Blue Band" or other clay partings in the seam, and clay is commonly seen mixed with crushed and rotated fragments of coal along the faults. Bedding-plane slippage also has occurred within the roof and at the coal-roof contact. In some cases slickensides allow determination of the direction of movement.

Normal and reverse faults have been offset along bedding-plane faults in numerous places (figs. 53 and 54).

At location F on figure 49, Fault "B" has been offset about 20 feet (6 m) by a single bedding-plane shear in the coal (fig. 53). The upper block has been displaced southward, obliquely updip, relative to the lower block. At location G (fig. 49) several bedding-plane faults, exhibiting varying amounts and directions of movement, have offset Fault "B." The result is a series of steps and overhangs in the coal seam (fig. 54).

On most of the bedding-plane shears in the Zeigler No. 4 Mine the block above the shear plane has moved relatively updip on the Pittsburgh Anticline. This sense of movement is the same as that observed in Study Area 5 in the Orient No. 4 Mine. In a few instances the upper block was observed to be displaced downdip.

Movement along bedding planes generally offsets and therefore probably postdates high-angle faulting. However, several examples were found of bedding-plane faults displaced by vertical movements. At the exposure illustrated in figure 55, a set of high-angle normal and reverse faults is offset by a horizontal fault in the coal, and the horizontal fault itself is offset by a small vertical movement. In other cases vertical and horizontal faults offset each other by approximately equal amounts; this suggests that the two movements occurred simultaneously.

Although the structure of Study Area 6 superficially resembles that of Study Area 5, the two areas are not subject to the same analysis. The two major faults in

Area 5 dip to the southwest and can be interpreted as essentially vertical extension fractures that have been tilted. Fault "A" in Study Area 6 cannot have developed in this manner because it dips in the opposite direction (northeast), yet has the northeastern block upthrown, and creates a high-angle reverse fault.

The structural development of Study Area 6 may have been similar to that proposed for Study Area 4 (fig. 56). Area 6 lies nearly on the projected line of the master fault zone so it is reasonable to believe that a continuous right-lateral fault may underlie the coal-bearing strata here. Strike-slip movements on the buried fault could have been accompanied by vertical movements of the main blocks or of slices within the fault zone. Some of the vertical movements may have been transmitted into the coal-bearing strata along a fault that becomes more gently dipping upward. In this case, only one fault, Fault

"A," reached the Herrin Coal. An alternate suggestion is that Fault "A" initially developed as a normal extensional fault with the northeast side downthrown. Subsequent wrenching stresses, transmitted from below, caused oblique slippage along Fault "A" in such a manner that the northeast block was locally upthrown to give the appearance of a reverse fault.

In any event, the displacement along bedding-plane faults is consistent with the displacement on Fault "A" and could have developed in the same action. On both Fault "A" and the bedding-plane faults, the northeastern (hanging) wall is displaced relatively upward. Minor northwest-trending normal faults in Study Area 6 are easily interpreted as simple extensional features fitting the overall pattern of the Cottage Grove Fault System. The small left-lateral faults at location E (fig. 49) are excellent examples of conjugate or second-order shears if Fault "A" is regarded

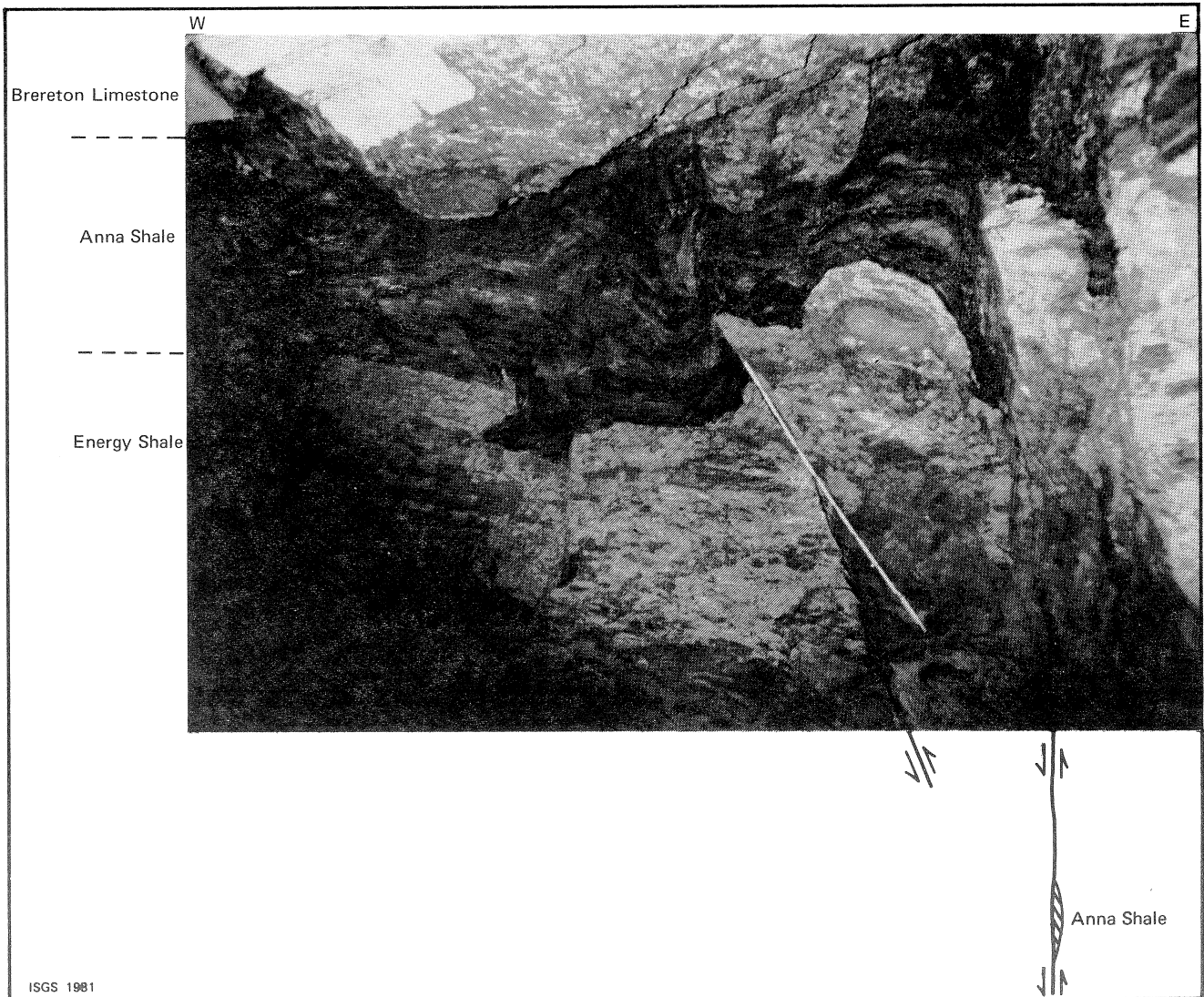

Figure 52. Small faults parallel with Fault "A" in Study Area 6 (fig. 51). Note that the Anna Shale is dragged or squeezed sharply downward along several of the faults, opposite the apparent direction of dip-slip. Note in particular the narrow slice of Anna Shale that lies along one of the faults 10 feet (3 m) below its normal position. These features indicate either a large component of strike-slip along these faults, or (more likely) that the walls of the faults were pulled apart by extensional forces such that the Anna Shale dropped downward into open fissures. Ruler is 4 feet (1.2 m) long.

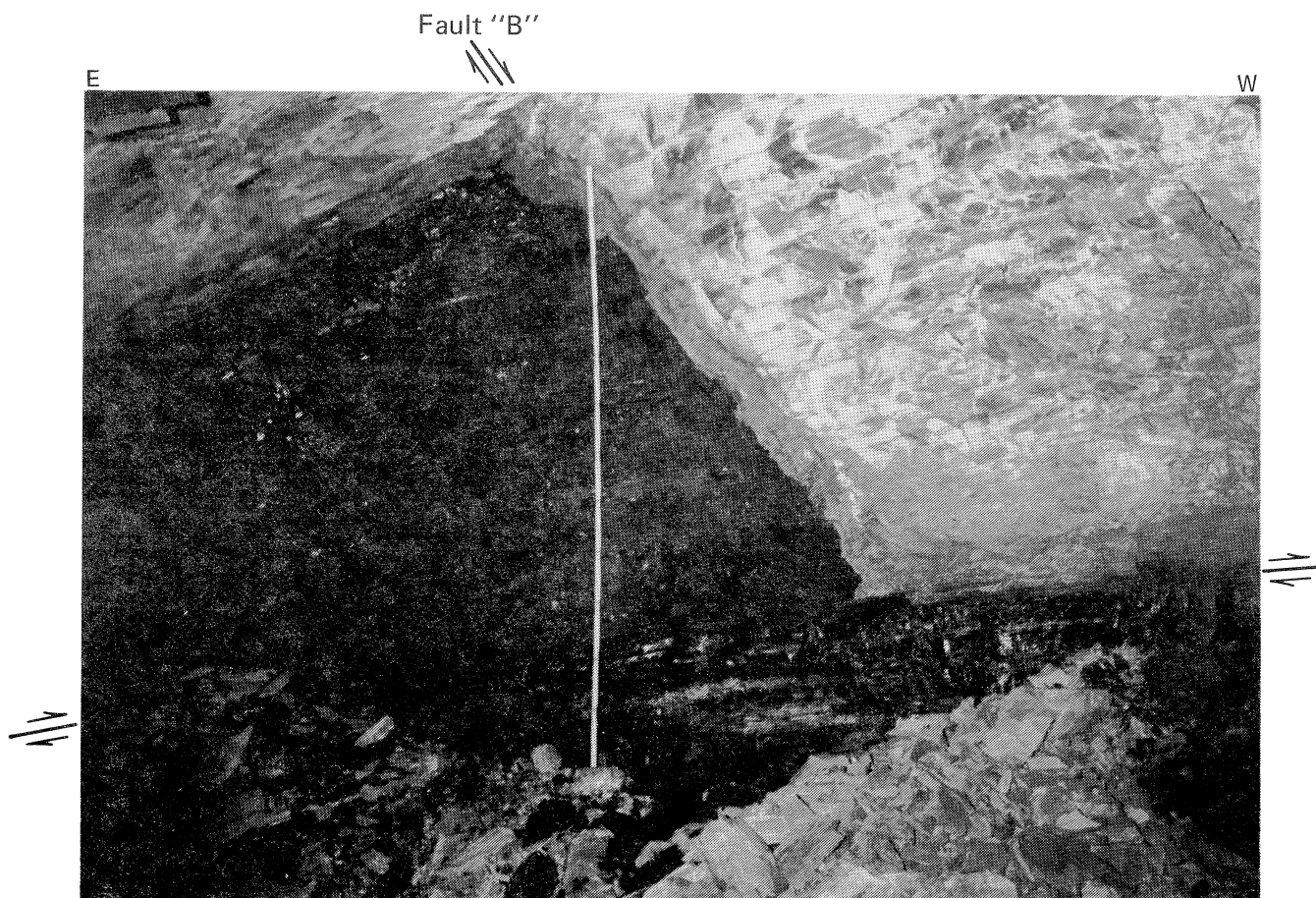

Figure 53. Fault "B" offset by bedding-plane fault at location F on figure 49. The upper block has moved at least 20 feet (6 m) to the west relative to the lower block. Note the dull, fractured appearance of coal in upper block compared to shiny coal with uninterrupted layering lower block. Ruler is 6 feet (1.8 m) long.

as a primary shear. Indeed, their presence strengthens the supposition that right-lateral movements took place on Fault "A."

A different hypothesis for the origin of the bedding-plane faults at Study Area 6 is possible. This interpretation requires the assumption that slippage along a strike-slip fault in the basement produced the structures in the coal along the Cottage Grove Fault System. We can see that a movement along the buried fault would not become immediately and directly expressed at the surface. The layered rocks overlying the fault would resist deformation and would attempt to retain their shape. One way in which slippage along the buried fault could have been accommodated was via slippage between layers. Layers such as the "Blue Band" and other clay partings in a coal seam could readily yield to this type of slippage.

We have shown that in most cases the horizontal shears offset and postdate high-angle faults in Study Areas 5 and 6. This observation is consistent with the theory we are outlining. In the early stages of slippage along the basement fault, perhaps the Cambrian and Ordovician rocks yielded to strike-slip movement on a master fault, but the Pennsylvanian strata were subjected only to mild folding and extensional subsidiary faulting. As movements

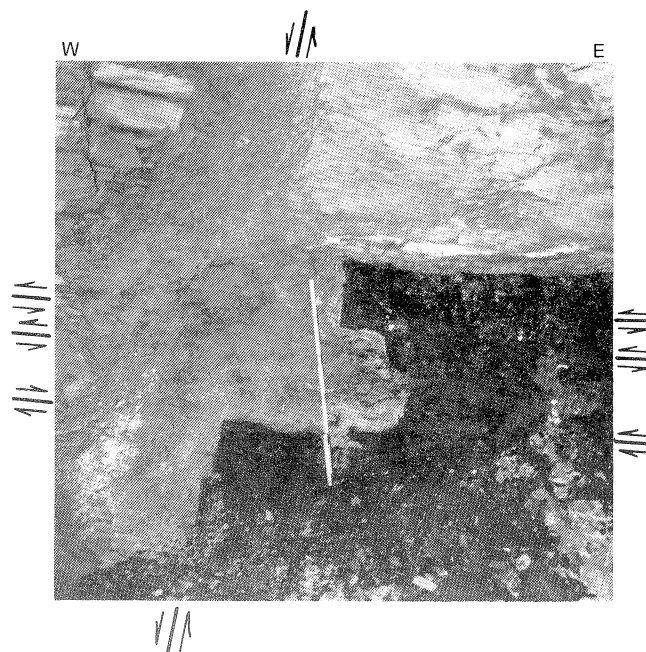

Figure 54. Fault "B" offset by multiple bedding-plane faults at location G, figure 49. Inconsistent direction of movement on horizontal faults has created a series of steps and overhangs. Ruler is 2 feet (0.6 m) long.

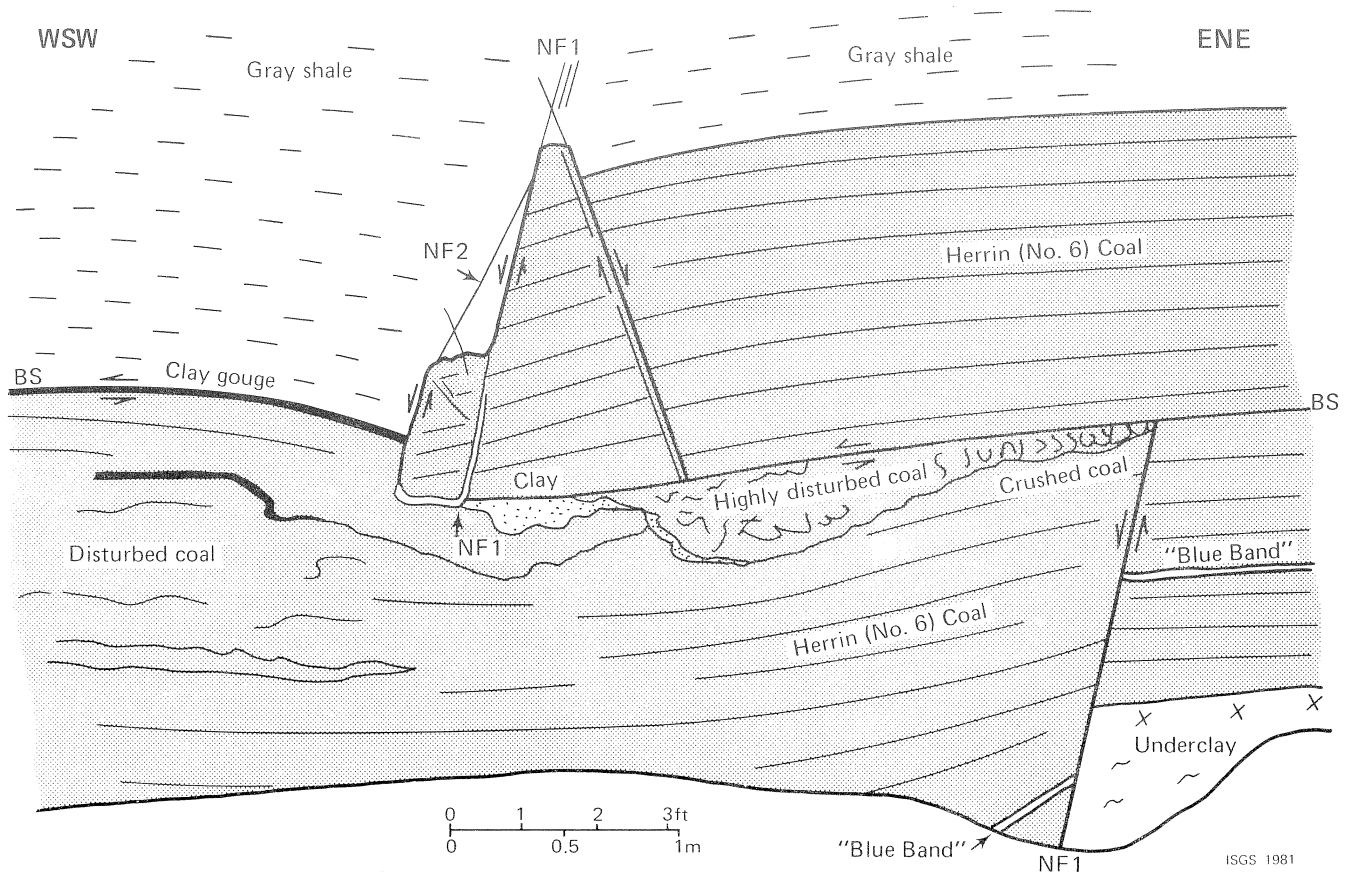

Figure 55. Vertical normal fault (NF1) offset by shearing parallel to bedding (BS). NF1 has about 3 feet (1 m) displacement and has been offset 10.6 feet (3.1 m) along BS. The upper block has moved from left to right. Shearing took place within the coal to the right of the normal fault and at the coal-roof contact to the left of the fault. The horizontal shear plane (BS) has itself been offset about 0.5 feet (0.15 m) by later movement on another normal fault (NF2).

below progressed, the master fault was propagated upwards, and the coal-bearing rocks were subjected to stronger wrenching forces. These stresses were relieved by oblique slippage along northwest-trending faults and by slippage parallel to bedding. The stresses were not prolonged quite enough to break the master fault through the Pennsylvanian rocks in Study Areas 5 and 6.

An advantage of the theory above is that it can be applied to all examples of bedding-plane faulting in the Cottage Grove Fault System—not just to that in Study Area 6. No special local geometry of faults, like that for the hypothesis discussed on page 49, is required for this theory.

The orientation of the Pittsburg Anticline in the vicinity of Study Areas 5 and 6 represents an apparent discrepancy in the structural pattern of the Cottage Grove Fault System. The anticlinal axis trends northwest, nearly parallel with the subsidiary faults and at considerable variance to the expected orientation of subsidiary anticlines in a zone of right-lateral wrenching. The Pittsburg Anticline, however, may not be entirely a compressional structure. The coincidence of the steeply dipping northeastern flank with the projected trend of the master fault suggests that the anticline in large part may be the result of direct vertical

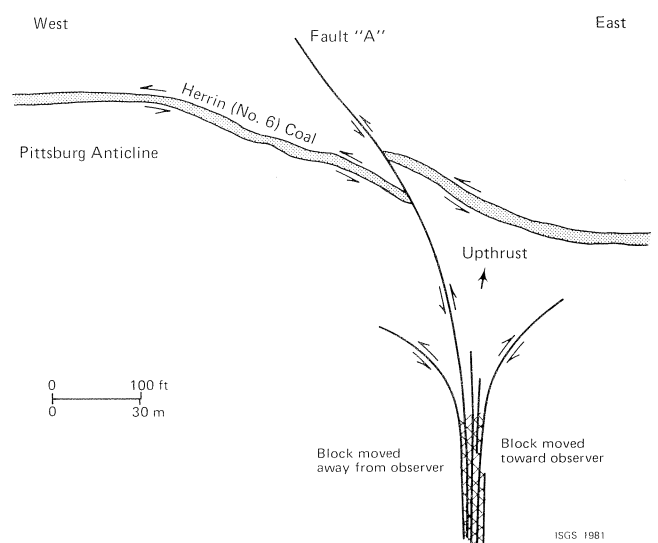

Figure 56. Hypothetical cross section of Study Area 6. Fault "A" may steepen downward and connect at depth with a vertical zone of right-lateral faulting. The reverse displacement on Fault "A," in this case, would be the result of upthrusting (compare fig. 38). Bedding-plane slippage as observed in coal is consistent with the direction of upthrusting. Wrenching or twisting stresses in Study Area 6 also may be responsible for movement along the bedding planes.

uplift. We postulate the existence of a continuous strike-slip fault at a depth below the coal-bearing strata. Movements along this fault created vertical offsets by displacing non-horizontal strata. Southeast of Study Area 5 the master fault zone is well-marked in the Herrin Coal, and the north side is downthrown as much as 200 feet (60 m). If similar offsets exist in sub-Pennsylvanian strata beneath Areas 5 and 6, the coal measures might have responded by forming a monoclinial fold draped across the fault. The same process might be responsible for the parallelism of the Brushy Anticline with the branches of the master fault in western Saline County.

Study Area 7

Study Area 7 is located east of Study Area 6 in the 2nd South Panel off the Main East of the Zeigler No. 4 Mine.* The Herrin Coal in Area 7 is essentially flat-lying, and a series of small northwest-trending faults has been mapped (fig. 57). These faults may be typical of subsidiary faults in the relatively unfolded areas away from the master fault.

The main fault of Study Area 7, as shown on coal company maps, maintains a heading of 155 degrees throughout its length (plate 1). It continues approximately half a mile (0.8 km) northwest of Zeigler's works into the abandoned works of Old Ben No. 9 Mine. Maps of the latter mine show the fault as a series of parallel, en echelon fractures with little throw and dying out to the northwest. Large blocks of unmined coal left along the fracture zone in panels attest to difficult mining conditions, probably unstable roof. Southeast of Study Area 7 the fault can be traced for 1,700 feet (520 m) through Zeigler No. 4 Mine, as shown on the company's maps. On the southeasternmost entry where the fault was encountered, the company map shows 9 feet (2.7 m) of displacement with the northeast side downthrown. Beyond this entry the fault enters a large block of coal left unmined because of faults and very steep dips in the coal. The fault may either die out to the southeast or it may curve slightly to the east and join the fault zone of Study Area 5.

The detailed map (fig. 57) of Study Area 7 reveals that the fault shown as a single line on Zeigler's map actually comprises numerous subparallel faults and fractures. Still greater complexity is shown on a sketch map (fig. 58) and a cross-section (fig. 59) of a single entry in Study Area 7. Many faults shown as single lines in figures 58 and 59 consist of parallel fractures spaced less than a millimeter apart. The detail with which the system can be described is limited only by the scale of the map and the patience of the observer.

Most of the faults are high angle (60° or greater) and show normal displacements. High-angle reverse faults are few but significant. Locally small-scale, low-angle reverse

movements can be detected within the coal or the overlying gray shale. No slippage parallel to bedding planes was observed. The faults appear to dip about equally to the northeast and to the southwest.

Individual faults are mainly discontinuous along strike and their displacements may differ considerably from one side of a heading to the next. The most dramatic example of changing displacement was found at Location A, figure 57, and involves two parallel faults. One fault is a normal fault having 5.4 feet (1.6 m) of throw on the north rib and only 0.3 feet (0.15 m) of throw on the south rib, less than 20 feet (6 m) away. The other fault is a reverse fault with 3.3 feet (1.0 m) of displacement on the north rib and 0.1 feet (0.03 m) on the south rib. The gouge zone of the normal fault remains wide on the south rib despite the small vertical offset, and fragments of gray shale from the roof were found along the fault plane several feet below the top of the seam.

One major reverse fault appears to be continuous throughout the mapped portion of Study Area 7. Its direction of dip remains constant and, except at Location A, its displacement changes gradually. In various entries it intersects normal faults to form narrow horsts, grabens, and tilted blocks. Generally, it offsets normal faults. Therefore the reverse fault must be younger than the normal faults.

The structural pattern of Study Area 7 is best explained as the result of two phases of movement. The first phase was extensional; it formed high-angle, en echelon normal faults. The second stage saw oblique slippage, probably right-lateral. Most of the oblique slippage took place along one normal fault (probably a series of fractures merged into one), which was transformed into an apparent reverse fault (which offsets normal faults). The abrupt changes of displacement, as at Location A, signify rotation of blocks during oblique slippage. The roof shale in the gouge zone of the normal fault at Location A may have been emplaced by the scissoring action, or by extensional pull-apart of the walls of the fault during the first stage of deformation.

East of Study Area 7 in the Zeigler No. 4 Mine, several other systems of northwest-trending faults were studied in less detail. The structural patterns shown by these faults are almost identical to those of Study Area 7. High-angle normal faults are predominant, but every system contains faults with apparent reverse displacement. Examples of "scissoring" were observed; in one case a fault changed from an apparent normal fault to an apparent reverse fault. Slickensides indicating oblique-slip movement are present on several faults. One fault surface had three sets of striations—one dip slip and two oblique slip. All of these features reinforce the hypothesis of two stages of movement: first extensional (normal faulting) and then oblique slippage.

*The Zeigler No. 4 Mine was abandoned shortly before this manuscript went to press.

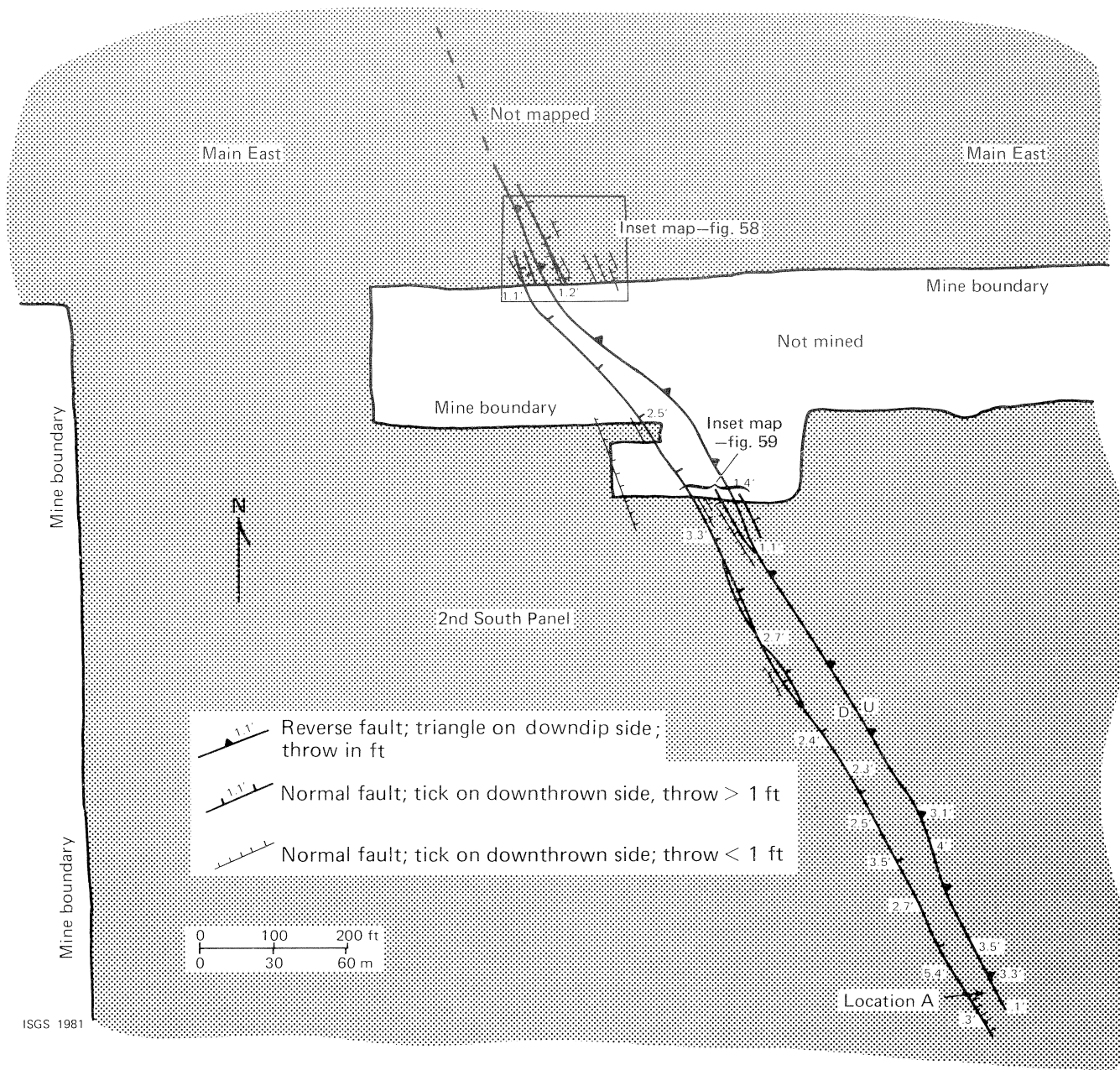

Figure 57. Faults in Study Area 7 in 2nd South Panel off Main East, Zeigler No. 4 Mine. Note insets for figures 58 (map) and 59 (sketch) showing more detail.

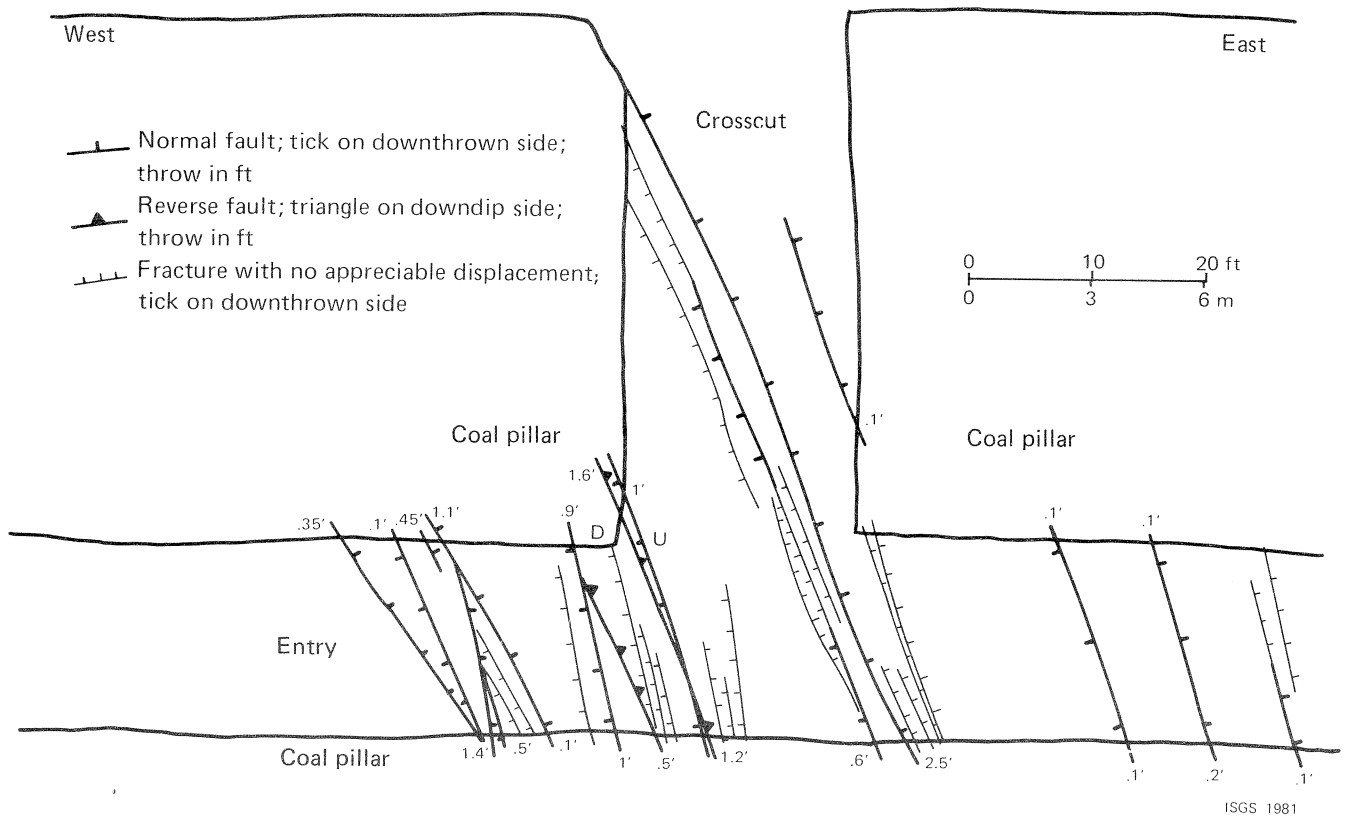

Figure 58. Enlarged sketch map of a portion of Study Area 7 (for location see fig. 57) included to illustrate structural complexity greater than that which can be shown in figure 57.

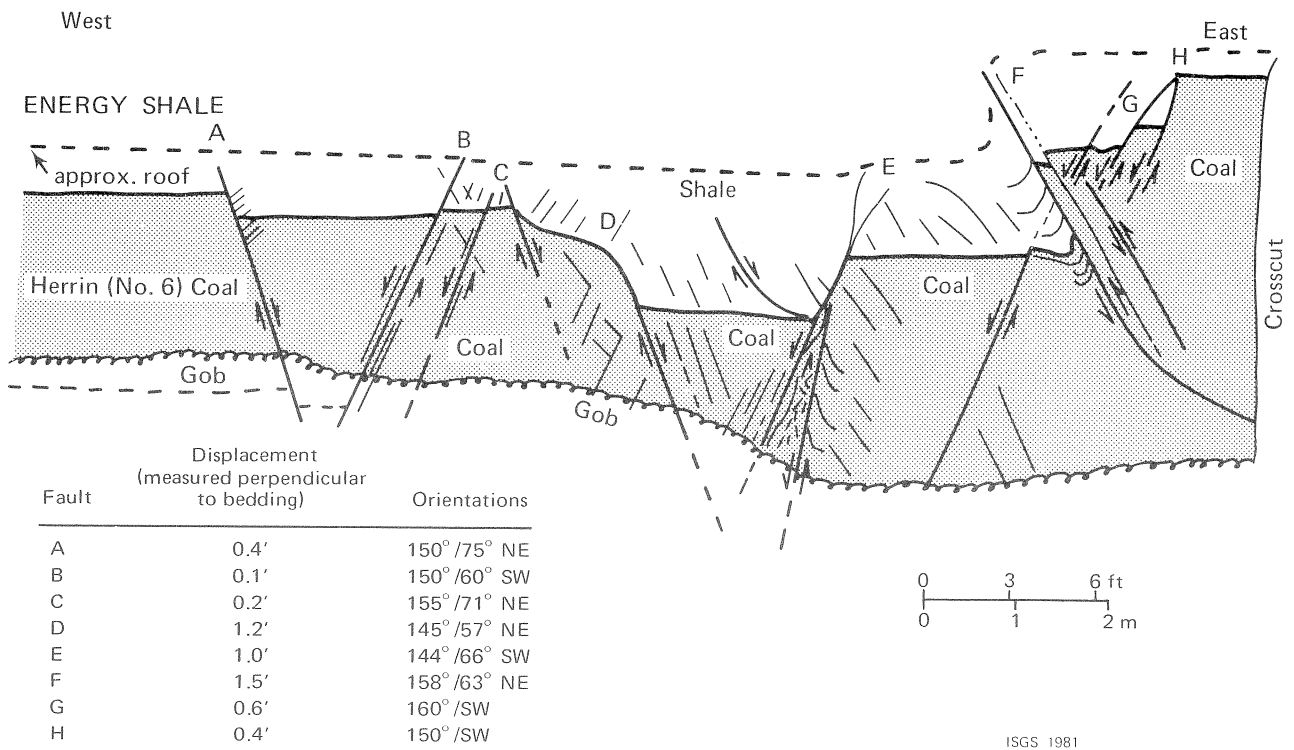

Figure 59. Faults in Study Area 7 (for location see fig. 57). Shown are numerous normal faults and one reverse fault (F).

ECONOMIC EFFECTS OF FAULTING

Oil and gas

The Cottage Grove Fault System has provided structural traps for oil and gas at several places along its length. Oil fields have been developed on the Campbell Hill and Pittsburg Anticlines, and successful wells have been drilled on other structures within the fault system.

The Campbell Hill Anticline (fig. 16) is known from surface exposures and was an early target for petroleum exploration. By 1928 producing wells numbered 27 in what became known as the Ava-Campbell Hill field. Most of these were gas wells, but some oil was also produced. The Cypress Sandstone was the main producing horizon, with additional recovery achieved from the Tar Springs Sandstone (fig. 3). The low production rates of wells in the Ava-Campbell Hill field are attributed to the irregularity and thinness of the sandstones serving as reservoirs (Root, 1928).

Since 1928, only one producing well (in the Cypress Sandstone) has been drilled on the anticline. Dry holes have been drilled, including one to the Galena Group (Trenton) and another to the St. Peter Sandstone (Ordovician) at

4,144 feet (1,263 m). The field went into decline and was closed down in 1943. After a brief phase of secondary recovery, the Ava-Campbell Hill field was abandoned in 1957. Total production is listed as 25,000 barrels of oil; figures on gas production are not available (Van Den Berg, 1976).

Three oil fields have been developed on the Pittsburg Anticline in Williamson County—from east to west, the Pittsburg North, the Johnston City East, and the Stiritz fields. The method of exploration leading to discovery of these fields is not positively known, but coal tests previously had shown the presence of the anticline (Cady et al., 1938).

The Pittsburg North field was discovered in 1962. Through 1979 the field has yielded 74,900 barrels of oil from the Bethel and Aux Vases Sandstones plus 10 million cubic feet of gas from the Hardinsburg Sandstone (Van Den Berg, 1979). One Devonian test was drilled to 4,785 feet (1,458 m), but no production has been obtained from sub-Chesterian strata.

Structurally, the Pittsburg North field is an irregular anticline that is probably flanked by faults on the northeast and southwest (fig. 60). Dry holes are located updip

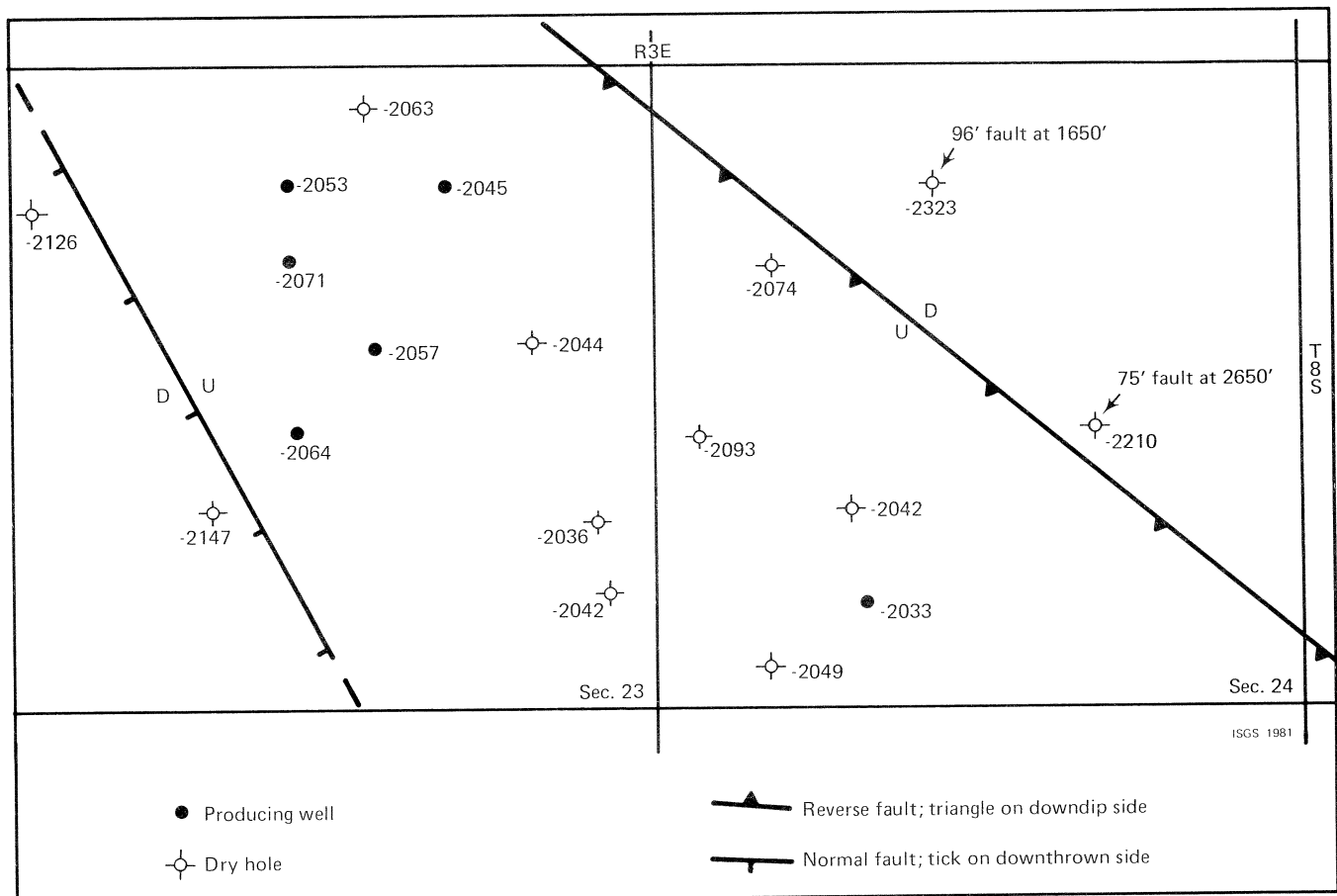

Figure 60. Map of Pittsburg North Oil Field with elevations of the base of the Renault Limestone. Oil production is from Bethel and Aux Vases Sandstones; the Hardinsburg Sandstone has yielded gas. Structure of the field is anticlinal with two large northwest-trending faults indicated. The northeasterly fault, a reverse fault with 75 to 100 feet (20 to 30 m) of vertical offset, is a continuation of Fault "A" from Study Area 5. Because some dry holes lie updip from producers, stratigraphic factors as well as structural must play a role in trapping hydrocarbons.

from producers; this indicates that stratigraphic as well as structural factors play a role in trapping hydrocarbons. The large reverse fault northeast of the producing area was penetrated by two drill holes and almost certainly connects with fault "A" of Study Area 5. The smaller fault southwest of the producing wells does not penetrate into the Herrin (No. 6) Coal.

The Johnston City East field is the most prolific field along the Cottage Grove Fault System. Through 1979, production totaled 1,109,300 barrels of oil and 931.3 million cubic feet of gas (Van Den Berg, 1979). Oil has been extracted from six horizons; the Cypress and Bethel Sandstones (Chesterian), the Aux Vases Sandstones (Valmeyeran), and the Ohara, Spar Mountain, and McClosky pay zones of the Ste. Genevieve Limestone. Gas production is from the Chesterian Tar Springs Sandstone. No holes to date have penetrated below the Ste. Genevieve Limestone.

The structure map (fig. 61) shows that the Johnston City East field actually contains two separate anticlinal reservoirs, probably bounded on the northeast by the Cottage Grove master fault zone. No holes penetrated the fault and the amount of displacement is not known. Quite possibly, as in the Herrin (No. 6) Coal, the master fault is discontinuous, and the elevation changes are due mainly to folding rather than faulting.

A second fault parallel with the master fault zone and downthrown to the southwest may be present. In one well along this inferred fault, the Tar Springs Sandstone is about 45 feet (14 m) thicker than normal. The thickening may be caused by repetition of strata along a reverse fault.

The westernmost oil production on the Pittsburg Anticline since 1971 is in the Stiritz field, about 2 miles (3.2 km) west of the Johnston City East field. Cumulative production through 1979 is 184,600 barrels of oil from the

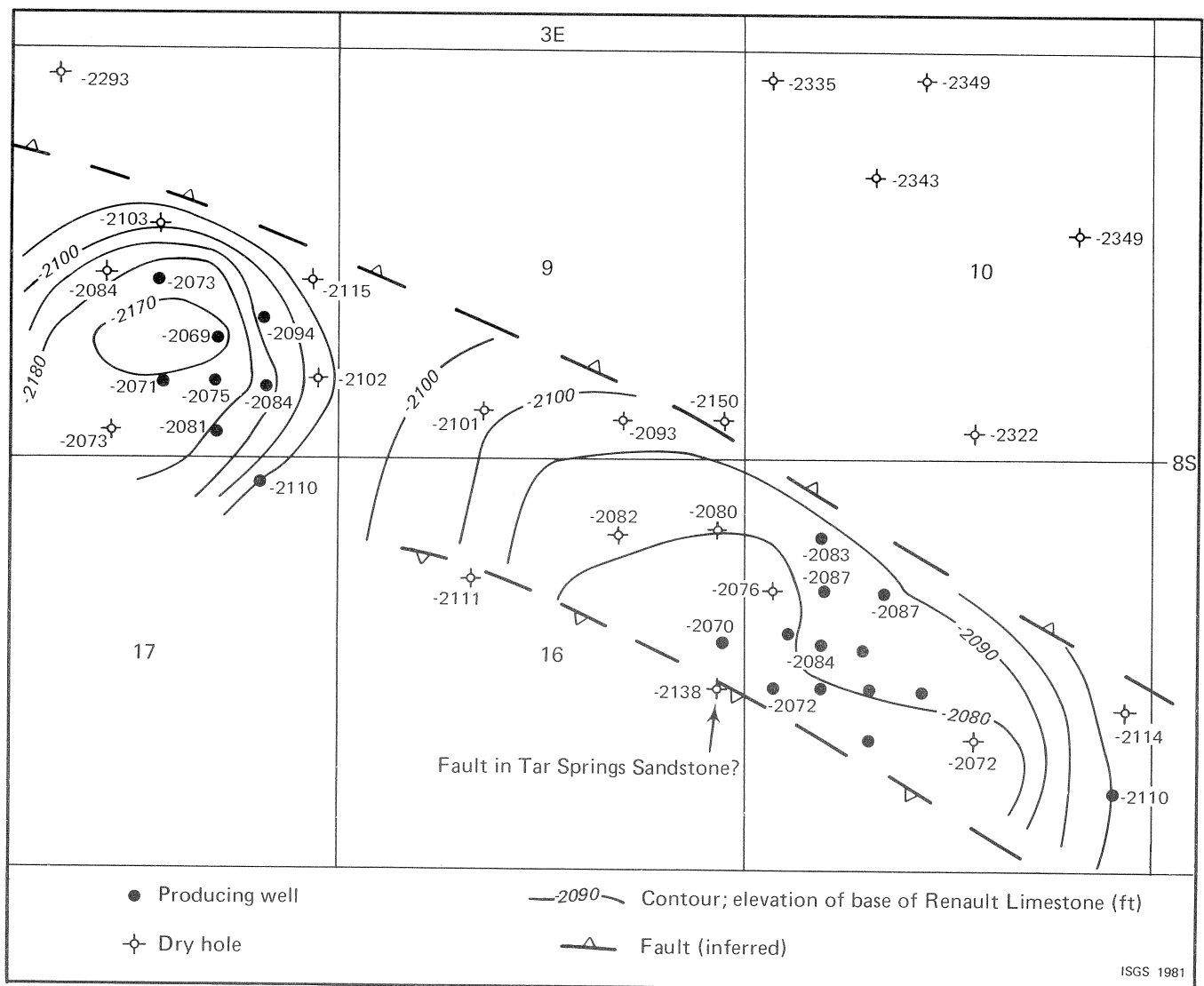

Figure 61. Johnston City East oil field with elevations and contours on base of Renault Limestone. The field appears to contain two separate reservoirs on the Pittsburg Anticline. The northeast fault, if present, is the Cottage Grove master fault zone. The southwest fault, less definitely indicated, probably is a subsidiary fault. The relative importance of faulting and folding in the structural pattern is not known. However, the structure closely resembles that seen in the Herrin (No. 6) Coal.

Bethel and Aux Vases Sandstones, and 68 million cubic feet of gas from the Tar Springs Sandstone (Van Den Berg, 1979). Sub-Chesterian strata have not been tested.

Structurally the Stiritz Field is an east-west trending anticline with 50 to 60 feet (15 to 18 m) of closure on the Beech Creek (Barlow) Limestone. The center of the field is about a mile south of the Cottage Grove master fault zone. Faults are probably present within the field, but none can be mapped from available data.

The deepest production to date within the Cottage Grove Fault System has been attained in the Vergennes field, Secs. 11 and 12, T. 7 S., R. 2 W., Jackson County. Four wells in the Vergennes field are pumping oil from Devonian limestone at a depth of about 3,300 feet (1,000 m). One well drilled to the Croixan (upper Cambrian) Eminence Formation at a total depth of 7,094 feet (2,162 m) encountered a show of oil in Galena (Trenton) Group Limestone (Ordovician). The Vergennes field is located near the crest of the Vergennes Anticline (fig. 15). Data are insufficient to permit mapping faults in the Devonian.

Other oil and gas production along the Cottage Grove Fault System is from fields with one to three wells. All are reduced to stripper production (less than 10 barrels of oil per day) from pay zones in Chesterian formations or in the Ste. Genevieve Limestone. The wells include one on the Cottage Anticline, several around Harrisburg, three in the Freeman Spur field in northwestern Williamson County, and one in the Elkville field of northeastern Jackson County.

To date no production has been achieved from sub-Devonian formations along the Cottage Grove Fault System, and the Devonian production is from one field. Few holes are drilled below the Chesterian units, and little is known of the petroleum potential of deeper formations along the fault system. Another explanation for the lack of deep recovery is that the structural configuration of the fault zone probably changes with depth. Structures in Chesterian strata generally reflect closely the structures in the Pennsylvanian rocks, but the same may not be true for the structure of Devonian and deeper strata. Much prospecting for oil in Illinois has been based upon the assumption, commonly true, that expressions of deep-seated structures can be detected in the rocks near the surface. This approach will probably have to be modified in searching for sub-Mississippian hydrocarbons along the CGFS.

The fold belt of the Cottage Grove Fault System generally marks the southern limit of extensive exploratory drilling and petroleum production in Illinois. Whereas prolific reservoirs have been discovered north of the system, only insignificant scattered discoveries have been made south of it. This dearth of drilling and production is partly related to localized increase in hardness and decrease in effective porosity of Chesterian sandstones (caused by mineralization of pore space). Difficulty in drilling due to this mineralization has been effectively reduced by the use of "button bits" rather than the conventional rock bits. Also on the plus side, selective mineralization of Chesterian

reservoir sandstones has led to stratigraphic entrapment of sizable petroleum accumulations in adjacent areas of Kentucky (Richard H. Howard, personal communication, 1980).

Coal mining

That the Cottage Grove Fault System is detrimental to coal mining should be obvious from the preceding pages. Large reserves of coal still exist along the Cottage Grove Fault System, a witness to the difficulties that faults have posed to mining operations. The purposes of this section are to describe some of the lesser-known effects of faults on mining, and to suggest improved methods of predicting faults and planning mines so as to minimize problems.

The greatest difficulties in mining occur close to the master fault zone. This is particularly true in areas where the master fault shows a complex structure, as in western Saline County and in Lake Creek Township, Williamson County. Miners working near the master fault may expect to encounter faults with virtually any orientation and displacement, as well as steep grades that may render the coal unminable. Many coal companies leave the entire fault zone unmined. If the faults can be located accurately in advance of mining, and if the property line is adjusted to follow the faults, loss of reserves can be minimized, because a pillar of unmined coal must be left along the property line in any event.

If it is necessary to mine across the master fault, a maximum of information about the structure should be obtained before planning the breakthrough. Drill holes must be spaced much more closely than is the practice in ordinary exploratory drilling. Intervals of 100 feet (30 m) or even less may be required to determine correctly the structure by drilling. Obtaining a detailed and accurate log of every hole is essential so that strata may be correlated correctly. Ideally, complete cores should be taken of every hole. Examination of the cores will allow the best possible identification of strata and may also reveal actual fault zones with fractured, crushed, or slickensided rock. If coring every hole is not feasible, the operator should hire a driller who is thoroughly knowledgeable in local stratigraphy and instruct him to keep as detailed a log as possible. In many cases, supplementing drillers' logs with geophysical logs is advisable. When a hole does not encounter the coal seam at the expected depth, drilling should be continued until either the coal or a marker bed below the coal is definitely identified.

An example of accurate delineation of structure through exploratory drilling is provided for Study Area 5 at the Orient No. 4 Mine of Freeman United Coal Mining Company (fig. 62). A series of holes was drilled along the projected line of the entries that were to cross the fault zone. A large portion of each hole was cored and the strata were carefully logged.

Holes A, B, and C encountered no faults but revealed

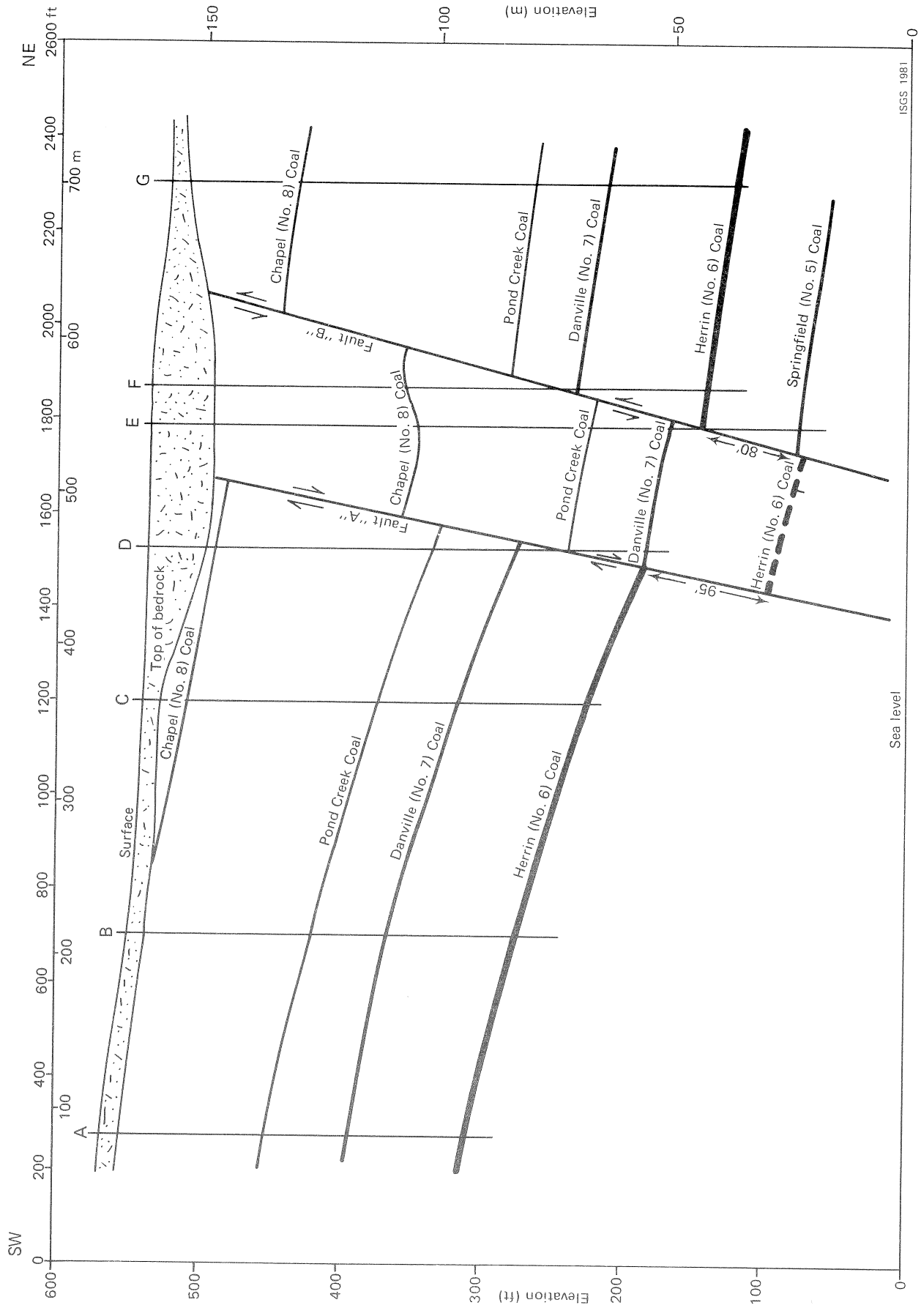

Figure 62. Cross section of fault zone in Study Area 5 (compare with fig. 40) illustrates how faults were located by drilling in advance of mining. Note bedrock valley over fault zone. Valley possibly reflects preferential erosion of fractured rock.

the increasing inclination of the coal approaching the fault zone. The log of Hole D showed repetition of 95 feet (29.0 m) of strata, including the Danville (No. 7) Coal, above the Herrin (No. 6) Coal. Thus Hole D located Fault "A" and proved that it is a reverse fault.

Eighty feet (24.4 m) of section including the Herrin Coal were missing from the log of Hole E; so Freeman's engineers knew that this hole had penetrated a normal fault (Fault "B"). A like amount of section was missing in Hole F between the Danville (No. 7) and Chapel (No. 8) Coal Members. By projecting a line between the position of the fault on logs of holes E and F, the dip of Fault "B" was determined. Drilling Hole G and other holes (not shown on fig. 62) proved that the Herrin Coal is relatively level and that no further large faults exist northeast of Fault "B."

Armed with the information derived from drilling, the company was able to mine through the fault zone with a minimum of expense and lost production. The entries were mined in the Herrin Coal up to Fault "A" and continued across without change in gradient. The continuous miner was able to cut the Danville Coal and the soft shale above with little difficulty. The competent Piasa Limestone was left as the roof and provided good stability. Small faults within the graben added complications, but presented no serious problem. Upon crossing Fault "B," the miners found themselves about 10 feet above the Herrin Coal. The entries were continued at the same gradient to intersect the coal, whereupon normal mining resumed. A relatively small amount of No. 6 Coal remains unmined northeast of Fault "B."

Subsidiary faults of the Cottage Grove System are less formidable obstacles than the master fault, but they still can make mining difficult. The structures can be complex, as experiences in Study Area 1, 2, 3, 6, and 7 illustrate (see also figs. 11 and 12). The small faults are difficult to locate by drilling, but once a fault has been encountered, its trend can generally be projected with fair assurance. Most subsidiary faults are composed of multiple fractures that may reverse direction of dip and displacement. Detrimental

effects of faulting, such as zones of fractures that weaken the roof, may be present some distance either side of the main break.

Igneous dikes can pose special problems in mining. The igneous rock can be extremely hard and impossible to cut with continuous miners or longwall face equipment. Furthermore, the coal adjacent to dikes may be mineralized and/or coked so that it is unsuitable for market. Most dikes are associated with parallel faults and fractures that add their special problems to those of the dikes. Somewhat in compensation, the dikes maintain consistent and predictable trends over long distances. A few of the largest ones are wide enough to be positively located with well-placed drill holes, or by means of magnetometer surveys.

Zones of intensely fractured coal and roof rock occur in the Cottage Grove Fault System not only in proximity to major faults, but sometimes at considerable distance from them. Some zones of fractures may represent the feathering ends of faults that attain large displacements elsewhere. Others may be related to folding of the strata, as in Study Area 4, (figs. 35 and 36). These fractures seriously weaken the roof and also increase the amount of dust produced in mining coal. The same effects may accompany zones where slippage has occurred parallel to bedding, as in Study Areas 5 and 6 (figs. 40 and 50).

Such zones of fracturing and shearing can be difficult or impossible to predict in advance of mining. Nonetheless, much can be done to reduce the hazard once its cause has been recognized and identified. Roof bolts can be anchored well above the fractured zone or, if this is not possible, supplementary supports can be placed. The direction of mining can be altered to avoid having fractures run parallel with mine openings. Rooms can be made narrower and pillars larger, at least on the advancing phase of mining, to minimize the hazard of roof failure.

In summary, the Cottage Grove Fault System poses considerable difficulty to coal mining. An understanding of the nature of the Cottage Grove Fault System can provide a basis for planning operations and for dealing most effectively with problems as they are encountered.

REFERENCES

- Baxter, James W., George A. Desborough, and Chester W. Shaw, 1967, Areal geology of the Illinois fluorspar district. Part 3, Herod and Shetlerville Quadrangles: Illinois State Geological Survey, Circular 413, 41 p.
- Baxter, James W., P. E. Potter, and F. L. Doyle, 1963, Areal geology of the Illinois fluorspar district; Part 1, Saline Mines, Cave-in-Rock, Dekoven, and Repton Quadrangles: Illinois State Geological Survey, Circular 342, 43 p.
- Billings, Marland P., 1954, Structural geology: Prentice-Hall, Inc. (2nd edition), 514 p.
- Bristol, Hubert M., and Janis D. Treworgy, 1979, The Wabash Valley Fault System in southeastern Illinois: Illinois State Geological Survey, Circular 509, 19 p.
- Brownfield, R. L., 1954, Structural history of the Centralia area: Illinois State Geological Survey, Reports of Investigations 172, 31 p.
- Butts, Charles, 1925, Geology and mineral resources of the Equality-Shawneetown area (parts of Gallatin and Saline Counties): Illinois State Geological Survey, Bulletin 47, 76 p.
- Cady, Gilbert H., 1916, Coal resources of District VI, Illinois State Geological Survey, Illinois Coal Mining Investigations, Bulletin 15, 94 p.
- Cady, Gilbert H., 1919, Coal resources of District V (Saline and Gallatin Counties), Illinois State Geological Survey, Illinois Coal Mining Investigations, Bulletin 14, 135 p.
- Cady, Gilbert H., 1925, Structure of parts of northeastern Williamson and western Saline Counties: Illinois State Geological Survey, Reports of Investigations 2, 19 p.
- Cady, G. H., E. T. Benson, E. F. Taylor, and others, contributions by A. H. Bell, 1938, Structure of Herrin (No. 6) Coal bed in central and southern Jefferson, southeastern Washington, Franklin, Williamson, Jackson, and eastern Perry Counties, Illinois: Illinois State Geological Survey, Circular 24, 12 p.
- Cady, G. H., E. F. Taylor, C. C. Boley, and others, contributions by A. H. Bell, 1939, Structure of Herrin (No. 6) Coal bed in Hamilton, White, Saline, and Gallatin Counties, Illinois, north of Shawneetown Fault: Illinois State Geological Survey, Circular 57, 18 p.
- Clark, Stuart K., and James S. Royds, 1948, Structural trends and fault systems in Eastern Interior Basin: Bulletin American Association of Petroleum Geologists, v. 32, no. 9, p. 1728-1749.
- Clegg, Kenneth E., 1955, Metamorphism of coal by peridotite dikes in southern Illinois: Illinois State Geological Survey, Reports of Investigations 178, 18 p.
- Clegg, K. E., and J. C. Bradbury, 1956, Igneous intrusive rocks in Illinois and their economic significance: Illinois State Geological Survey, Reports of Investigations 197, 19 p.
- Cloos, H., 1928, Experimente zur inneren Tektonik: Centralbl. f. Mineral. u. Pal., v. 1928B, p. 609-621.
- Cote, William E., David L. Reinertsen, Myrna M. Killey, 1969, Geological science field trip—Equality area: Guide leaflet 1969 A and F, Illinois State Geological Survey, 27 p.
- DeWolf, F. W., 1907, Coal investigations in the Saline-Gallatin field, Illinois, and the adjoining area: U.S. Geological Survey Bulletin 316, p. 116-136; Illinois State Geological Survey, Bulletin 8, p. 211-229.
- Fath, A. E., 1920, The origin of faults, anticlines, and buried "granite ridge" of the northern part of the Mid-Continent oil and gas field: U.S. Geological Survey Professional Paper 128-C, p. 75-84.
- Fisher, D. J., 1925, Structure of Herrin (No. 6) Coal seam near Du Quoin: Illinois State Geological Survey, Reports of Investigations 5, 34 p.
- Foley, Lyndon L., 1926, The origin of the faults in Creek and Osage Counties, Oklahoma: Bulletin American Association of Petroleum Geologists, v. 10, no. 3, p. 293-303.
- Gibbons, John F., 1972, Tectonics of the eastern Ozarks area, southeastern Missouri: unpublished Ph.D. thesis, Syracuse University.
- Hamblin, W. K., 1965, Origin of "reverse drag" on the downthrown side of normal faults: Geological Society of America Bulletin, v. 75, p. 1145-1164.
- Harding, T. P., 1974, Petroleum traps associated with wrench faults: Bulletin American Association of Petroleum Geologists, v. 58, no. 7, p. 1290-1304.
- Heyl, A. V., Jr., 1972, The 38th Parallel Lineament and its relationship to ore deposits: Economic Geology, v. 67, p. 874-894.
- Heyl, A. V., Jr., and M. R. Brock, 1961, Structural framework of the Illinois-Kentucky mining district and its relation to mineral deposits: U.S. Geological Survey Professional Paper 424-D, p. D3-D6.
- Heyl, A. V., Jr., M. R. Brock, J. L. Jolly, and C. E. Wells, 1965, Regional structure of the southeast Missouri and Illinois-Kentucky mineral districts: U.S. Geological Survey Bulletin 1202-B, 20 p.
- Hobbs, S. Warren, and Verne C. Fryklund, 1968, The Coeur d'Alene district, Idaho, in Ore deposits of the United States 1933/1967: Rocky Mt. Fund Series, American Institute of Mining and Metallurgical Engineers, p. 1415-1435.
- Hopkins, M. E., R. B. Nance, and C. G. Treworgy, 1979, Mining geology of Illinois coal deposits, in Depositional and structural history of the Pennsylvanian system of the Illinois Basin, part 2; field trip 9, Ninth International Congress of Carboniferous Stratigraphy and Geology, p. 142-151.
- Johnson, Donald O., 1972, Stratigraphic analysis of the interval between the Herrin (No. 6) Coal and the Piasa Limestone in southwestern Illinois: unpublished Ph.D. thesis, University of Illinois, Urbana, IL, 105 p.
- Kay, Fred H., 1916, Notes on Bremen Anticline—Randolph County: Illinois State Geological Survey, Bulletin 33, p. 101-103.
- Keys, John N., 1978, An analysis of the Rend Lake Fault System in southern Illinois: unpublished M.S. thesis, University of Illinois, Urbana, IL, 59 p.
- Keys, John N., and W. John Nelson, 1980, The Rend Lake Fault System in southern Illinois: Illinois State Geological Survey, Circular 513, 23 p.
- Krause, H.-F., and John N. Keys, 1977, The Rend Lake Fault System and accompanying deformational features observed in the Herrin (No. 6) Coal member: Abstract, Geological Society of America North Central Section Meeting, Carbondale, IL, April 1977, p. 617.
- Krause, H.-F., W. John Nelson, and Howard R. Schwalb, 1979, Clear Run Horst of Rough Creek Fault System, Green River Parkway, Milepost 53, in Palmer and Dutcher [eds], Depositional and structural history of the Pennsylvanian System of the Illinois Basin. Part 1. Road log and description of stops, Field trip 9: Ninth International Carboniferous Congress, p. 43-48.
- Moody, J. D., and M. J. Hill, 1956, Wrench-fault tectonics: Bulletin Geological Society of America, v. 67, p. 1207-1246.
- Piskin, Kemal, and Robert E. Bergstrom, 1975, Glacial drift in Illinois: thickness and character: Illinois State Geological Survey, Circular 490, 35 p.
- Riedel, W., 1929, Zur Mechanik geologischer Brucher Scheinungen: Centralbl. f. Mineral. Geol. u. Pal., u. 1929 B, p. 354-368.
- Root, T. B., 1928, The oil and gas resources of the Ava-Campbell Hill area: Illinois State Geological Survey, Reports of Investigations 16, 27 p.

- Schwalb, Howard, R., 1979, Stratigraphic and structural history of the Moorman Syncline (Rough Creek Graben) in western Kentucky: Abstract, Geological Society of America South Central Section Meeting, Mountain View, Arkansas.
- Schwalb, Howard, R., in press, Western Kentucky-faults and unconformities-keys to exploration: Kentucky Geological Survey.
- Schwalb, Howard R., and Paul E. Potter, 1978, Structure and isopach map of the New Albany-Chattanooga-Ohio Shale (Devonian and Mississippian) in Kentucky-western sheet: Kentucky Geological Survey, Series X.
- Shaw, E. W., 1910, The geology and coal resources of the Murphysboro Quadrangle, in De Wolf, F. W., Yearbook for 1909: Illinois State Geological Survey, Bulletin 16, 402 p. (p. 286-294).
- Sherrill, R. E., 1929, Origin of the en echelon faults in north-central Oklahoma: Bulletin American Association of Petroleum Geologists, v. 13, no. 1, p. 31-37.
- Siever, Raymond, 1951, The Mississippian-Pennsylvanian unconformity in southern Illinois: Illinois State Geological Survey, Reports of Investigations 152, 39 p.
- Smith, Avery E., and James E. Palmer, 1974, More testing needed in thrust faults of western Kentucky's Rough Creek fault system: The Oil and Gas Journal, July 8, 1974, p. 133-138.
- Smith, William H., and John B. Stall, 1975, Coal and water resources for coal conversion in Illinois: Illinois State Geological Survey, Cooperative Resources Report 4, 79 p.
- Stonehouse, H. B., and G. M. Wilson, 1955, Faults and other structures in southern Illinois—a compilation: Illinois State Geological Survey, Circular 195, 4 p.
- Swann, D. H., 1963, Classification of Genevievian and Chesterian (late Mississippian) rocks of Illinois: Illinois State Geological Survey, Reports of Investigations 216, 91 p.
- Tchalenko, J. S., 1970, Similarities between shear zones of different magnitudes: Geological Society of America Bulletin, v. 81, p. 41-60.
- Tchalenko, J. S., and N. N. Ambraseys, 1970, Structural analysis of the Dasht-e Bayaz earthquake fractures: Geological Society of America Bulletin, v. 81, p. 41-60.
- Thomas, Gilbert E., 1974, Lineament-block tectonics, Williston-Blood Creek Basin: Bulletin American Association of Petroleum Geologists, v. 58, no. 7, p. 1305-1322.
- Trace, Robert D., 1974, Illinois-Kentucky fluorspar district, in A symposium on the geology of fluorspar: Proceedings of the Ninth Forum on Geology of Industrial Minerals, Kentucky Geological Survey Special Publication 22, p. 58-76.
- Van Den Berg, Jacob, 1976, Petroleum industry in Illinois, 1976: Illinois State Geological Survey, Illinois Petroleum 112, 130 p.
- Van Den Berg, Jacob, and Jaclyn Elyn, 1981, Petroleum industry in Illinois, 1979: Illinois State Geological Survey, Illinois Petroleum 120, 132 p.
- Weller, Stuart, 1915, Anticlinal structure in Randolph County: Illinois State Geological Survey, Bulletin 31, p. 69-70.
- Wilcox, Ronald E., T. P. Harding, and D. R. Seely, 1973, Basic wrench tectonics: Bulletin American Association of Petroleum Geologists, v. 57, no. 1, p. 74-96.
- Willman, H. B., Elwood Atherton, T. C. Buschbach, Charles Collinson, John C. Frye, M. E. Hopkins, Jerry A. Lineback, and Jack A. Simon, 1975, Handbook of Illinois stratigraphy: Illinois State Geological Survey, Bulletin 95, 261 p.
- Zartman, R. E., M. R. Brock, A. V. Heyl, and H. H. Thomas, 1967, K-Ar and Rb-Sr ages of some alkaline intrusive rocks from central and eastern United States: American Journal Science, v. 265, no. 10, p. 848-870.

Jack A. Simon, D.Sc., Chief, *On Leave*
Robert E. Bergstrom, Ph.D., Acting Chief

Julian H. Lauchner, Ph.D., Administrative Engineer

Leonard Bantz, B.S., Fiscal Assistant to the Chief

Dorothy M. Spence, Secretary to the Chief

GEOLOGICAL GROUP

James C. Bradbury, Ph.D., Geologist, *In Charge*

David L. Gross, Ph.D., Coordinator, Environmental Geology

Marilyn L. Rebecca, Secretary II

COAL SECTION

Heinz H. Damberger, Ph.D., Geologist and Head
Richard D. Harvey, Ph.D., Geologist
Russel A. Peppers, Ph.D., Geologist
C. Brian Trask, Ph.D., Associate Geologist
Robert A. Bauer, B.S., Assistant Geologist
Dwain J. Berggren, M.A., Assistant Geologist
Chen-Lin Chou, Ph.D., Assistant Geologist
W. John Nelson, M.S., Assistant Geologist
Philip L. Robare, M.A., Assistant Geologist
Colin G. Treworgy, B.A., Assistant Geologist
Stephen K. Danner, B.S., Assistant Geologist I
Russell J. Jacobson, B.A., Assistant Geologist I
Donald J. Lowry, A.B., Research Assistant
Cynthia A. Morgan, B.S., Research Assistant
Philip J. DeMaris, M.S., Special Research Associate
Margaret H. Bargh, B.S., Special Research Assistant

OIL AND GAS SECTION

Richard H. Howard, M.S., Geologist and Head
Howard R. Schwalb, B.S., Geologist
Robert M. Cluff, M.S., Associate Geologist
Jacob Van Den Berg, M.S., Associate Geologist
Beverly Seyler, M.A., M.S., Assistant Geologist
Mary H. Barrows, B.S., Assistant Geologist I
Jaelyn R. Elyn, Ph.D., Research Assistant
Bernita I. Allen, Technical Assistant

ENGINEERING GEOLOGY SECTION

Paul B. DuMontelle, M.S., Geologist and Head
Christopher J. Stohr, M.S., Associate Geologist
Myrna M. Killey, M.S., Assistant Geologist
Robert J. Krumm, B.S., Research Assistant
Edward G. Scoggin, A.B., Administrative Assistant
Rebecca J. Bianchini, Technical Assistant
Paul V. Heinrich, M.S., Special Assistant Geologist

GEOLOGICAL RECORDS UNIT

Connie L. Maske, B.A., Supervisor
Mindy C. James, B.A., Technical Assistant
in charge of Map Room
Carol L. Cantello, B.A., Technical Assistant
Anne C. Faber, B.S., Technical Assistant
Barbara J. Herrinton, B.S., Technical Assistant
Linda A. Johnson, Technical Assistant
Leticia Klatt, B.A., Technical Assistant
Pamela L. Zierath, B.A., Technical Assistant

EDUCATIONAL EXTENSION UNIT

David L. Reinertsen, A.M., Geologist and Head
George R. Carlisle, Jr., B.S., Research Assistant

TOPOGRAPHIC MAPPING PROGRAM

Paul B. DuMontelle, M.S., Coordinator

MINERAL ECONOMICS

Subhashchandra B. Bhagwat, Dr.-Ing.,
Mineral Economist and Head
Irma Samson, Research Assistant

CHEMICAL GROUP

Neil F. Shimp, Ph.D., Principal Chemist

Alberta R. Zachay, Administrative Assistant

Ralph S. Boswell, Technical Assistant

Gail M. Gray, B.S., Technical Assistant

ANALYTICAL CHEMISTRY SECTION

Rodney R. Ruch, Ph.D., Chemist and Head
Dennis D. Coleman, Ph.D., Geochemist
Joyce Kennedy Frost, Ph.D., Chemist
Josephus Thomas, Jr., Ph.D., Physical Chemist
Raymond S. Vogel, B.S., Chemist
Richard A. Cahill, M.S., Associate Chemist
Robert R. Frost, Ph.D., Associate Physical Chemist
Robert A. Keogh, B.S., Associate Chemist
Chao-Li Liu, M.S., Associate Chemist

HYDROGEOLOGY AND GEOPHYSICS SECTION

Keros Cartwright, Ph.D., Geologist and Head
Leon R. Follmer, Ph.D., Geologist
John P. Kempton, Ph.D., Geologist
Paul C. Heigold, Ph.D., Geophysicist
Ross D. Brower, M.S., Associate Geologist
William G. Dixon, Jr., A.M., Associate Geologist
Robert H. Gilkeson, M.S., Associate Geologist
Thomas M. Johnson, M.S., Associate Geologist
Jean I. Larsen, M.A., Associate Geologist
Philip C. Reed, A.B., Associate Geologist
Henry J. H. Harris, Ph.D., Assistant Geologist
Beverly L. Herzog, M.S., Assistant Geologist
Kemal Piskin, M.S., Assistant Geologist
Timothy H. Larson, M.S., Assistant Geologist I
Vickie L. Poole, B.S., Assistant Geologist I
Barbara A. Roby, B.S., Research Associate
Karen L. Vivian, Technical Assistant
Hildegard O. Minc, B.S., Special Research Associate
Walter J. Morse, B.S., Special Research Associate

STRATIGRAPHY AND AREAL GEOLOGY SECTION

Charles Collinson, Ph.D., Geologist and Head
Herbert D. Glass, Ph.D., Geologist
David L. Gross, Ph.D., Geologist
Dennis R. Kolata, Ph.D., Geologist
Jerry A. Lineback, Ph.D., Geologist (on leave)
Lois S. Kent, Ph.D., Associate Geologist
Rodney D. Norby, Ph.D., Associate Geologist
Donald G. Mikulic, Ph.D., Assistant Geologist
Michael L. Sargent, M.S., Assistant Geologist
David A. Burke, B.S., Research Assistant
Margie D. Eastin, Technical Assistant
Helen G. Hannah, Technical Assistant
Joanne L. Mikulic, Technical Assistant
Richard C. Berg, Ph.D., Special Assistant Geologist
Ardith K. Hansel, Ph.D., Special Assistant Geologist
Janis D. Treworgy, B.S., Special Research Associate
Jeanine L. Morse, B.S., Special Research Assistant
Jacquelyn L. Hannah, Special Technical Assistant

INDUSTRIAL MINERAL SECTION

James W. Baxter, Ph.D., Geologist, *In Charge*
James C. Bradbury, Ph.D., Geologist and Head
Randall E. Hughes, Ph.D., Geologist
Jonathan H. Goodwin, Ph.D., Associate Geologist
John M. Masters, M.S., Associate Geologist
George M. Wilson, M.S., Assistant Geologist (on leave)

GEOLOGICAL SAMPLES LIBRARY UNIT

Robert W. Frame, Superintendent
Charles J. Zelinsky, A.G.S., Assistant Superintendent
Patricia L. Johnson, Technical Assistant
John F. Klitzing, Technical Assistant
Harris R. McKinney, Technical Assistant

CHEMICAL GROUP *Continued*

MINERALS ENGINEERING SECTION

Carl Kruse, Ph.D., Chemist and Head
L. A. Khan, Ph.D., Associate Mineral Engineer
Lawrence B. Kohlenberger, B.S., Associate Chemist
Larry R. Camp, B.S., Assistant Chemist

Chusak Chaven, Ph.D., Assistant Chemist
Jimmie D. Cooper, Research Assistant
H. Vaughan Jones, Ph.D., Visiting Scientist

GEOCHEMISTRY SECTION

Robert A. Griffin, Ph.D., Geochemist and Head
Donald R. Dickerson, Ph.D., Organic Chemist
Richard H. Shiley, M.S., Organic Chemist
Sheng-Fu Chou, Ph.D., Associate Organic Chemist
Mei-In Melissa Chou, Ph.D., Assistant Organic Chemist

Rudolph M. Schuller, M.S., Assistant Geochemist
William R. Roy, M.A., Assistant Geochemist I
Kenneth Konopka, B.A., Research Assistant
Ivan G. Krapac, B.S., Special Research Associate

ADMINISTRATIVE GROUP
Julian H. Lauchner, Ph.D., Head

SPONSORED RESEARCH AND PROJECTS OFFICE
Julian H. Lauchner, Ph.D., Research and Projects Officer
Peter X. Sarapuka, A.B., Research Associate

FINANCIAL OFFICE
Leonard Bantz, B.S., Fiscal Officer
Lonnie W. Moore, B.S., Fiscal Assistant
Pauline Mitchell, Accountant II
Nona Neal, Account Technician I

TECHNICAL RECORDS UNIT
Miriam Hatch, Supervisor
Carol E. Fiock, Technical Assistant
Jo Ann Munnis, Technical Assistant

CLERICAL SERVICES
Mary E. McGuire, Clerk Stenographer III, Supervisor
Miriam D. Boyd, Clerk Stenographer II
Linda M. Innes, Clerk Stenographer II
Edna M. Yeargin, Clerk Stenographer II
Laurie P. Leahey, Clerk Stenographer I
Rebecca A. McFarland, Clerk Typist III (typesetter)
Jacqueline L. Keogh, Clerk Typist II
Margo Anderson, Clerk Typist I

PUBLICATIONS UNIT
Ione L. Nielsen, B.A., Technical Editor and Coordinator
Mary Z. Glockner, B.A., Technical Editor
Ellen W. Stenzel, B.A., Assistant Editor
Fred Graszer, B.A., Geologic Draftsman
Craig W. Ronto, A.F.A., Geologic Draftsman
Sandra K. Stecyk, B.F.A., Geologic Draftsman
Patricia A. Whelan, B.F.A., Geologic Draftsman
William Dale Farris, Scientific Photographer
Ilona Sandorfi, Geologic Draftsman (on leave)

COMPUTER SERVICES UNIT
L. H. Van Dyke, M.S., Geologist and Head
Sally L. Denhart, A.A.S., Assistant Programmer I
Ilana Bilgory, M.S., Research Assistant
Linda S. Cooper, A.B., Research Assistant
Patricia A. Helm, Data Entry Operator
Joan K. Junkins, Data Entry Operator
Deborah A. Gaines, Special Technical Assistant

SPECIAL TECHNICAL SERVICES
Earnest Adair, Technical Assistant
David B. Cooley, Administrative Assistant
Joseph S. Kaczanowski, Instrument Specialist
Dennis L. Reed, Distribution Supervisor
Randel D. Watterson, Technical Assistant
Chris R. Wilson, Technical Assistant

GENERAL SCIENTIFIC INFORMATION
Marilynn L. Farnham, B.A., Technical Assistant
Dorothy H. Huffman, Technical Assistant
Kelly J. Anderson, B.A., Technical Assistant

LIBRARY
Mary P. Krick, M.S., Geological Librarian
Kristi M. Komadina, B.A., Assistant Librarian

PERSONNEL
Julian H. Lauchner, Ph.D., Personnel Officer
Nancy J. Hansen, Secretary I

* * * * *

EMERITI

John C. Frye, Ph.D., D.Sc., Chief
Glenn C. Finger, Ph.D., Principal Chemist
M. L. Thompson, Ph.D., Principal Research Geologist
W. H. Voskuil, Ph.D., Principal Mineral Geologist
Elwood Atherton, Ph.D., Geologist
Donald C. Bond, Ph.D., Head, Oil and Gas Section
Willis L. Busch, A.B., Economic Analyst
T. C. Buschbach, Ph.D., Geologist
R. J. Helfinstine, M.S., Mechanical Engineer
Wayne F. Meents, Geological Engineer
W. Calhoun Smith, Ph.D., Geologist

W. H. Smith, M.S., Geologist
Enid Townley, M.S., Geologist
W. Arthur White, Ph.D., Geologist
Lester L. Whiting, M.S., Geologist
H. B. Willman, Ph.D., Geologist
Juanita Witters, M.S., Physicist
W. J. Armon, M.S., Associate Chemist
Hubert M. Bristol, M.S., Associate Geologist
Kenneth E. Clegg, M.S., Associate Geologist
Thomas F. Lawry, B.S., Associate Petroleum Engineer

RESEARCH AFFILIATES AND CONSULTANTS

Richard C. Anderson, Ph.D., Augustana College
Donald L. Graf, Ph.D., University of Illinois
S. E. Harris, Jr., Ph.D., Southern Illinois University
John Hower, Jr., Ph.D., University of Illinois
W. Hilton Johnson, Ph.D., University of Illinois
A. Byron Leonard, Ph.D., University of Kansas
Lyle D. McGinnis, Ph.D., Northern Illinois University
I. Edgar Odom, Ph.D., Northern Illinois University
Tommy L. Phillips, Ph.D., University of Illinois
Frederich R. Schram, Ph.D., San Diego Natural History Museum
T. K. Searight, Ph.D., Illinois State University
Robert B. Votaw, Ph.D., Indiana University
George W. White, Ph.D., University of Illinois

Topographic mapping in cooperation with the United States Geological Survey.